



**Tools cut better  
with TIGRA**



**2023**











**Woodworking**

**Holzbearbeitung**

**Travail du bois**

**Lavorazione del legno**

**Famegmunkálás**

	<p>EN Technical data</p> <p>DE Technische Daten</p> <p>FR Caractéristiques techniques</p>	<p>IT Dati tecnici</p> <p>HU Műszaki adatok</p>
	<p>EN Reversible knives and edge rounding knives</p> <p>DE Wendeschneidplatten und Kantenrunder</p> <p>FR Plaquettes réversibles et couteaux brise-arrête</p>	<p>IT Coltelli reversibili e spigolatori</p> <p>HU Váltólapkák és éllekerekítők</p>
	<p>EN Blanks for profiling and radius knives</p> <p>DE Blanketts zum Profilieren und Radienplatten</p> <p>FR Plaquettes à profiler et plaquettes profilées</p>	<p>IT Placchette da profilare e placchette profilate</p> <p>HU Profilozható nyerslapkák és rádiuszos kések</p>
	<p>EN Saw tips and strobe blanks</p> <p>DE Sägezähne und Wischerblätter</p> <p>FR Dents de scie et racleurs</p>	<p>IT Dentelli per lame e barrette per rasanti</p> <p>HU Fűrészfogak és tisztítófogak</p>
	<p>EN Carbide for brazed tools</p> <p>DE Hartmetall für gelötete Fräser</p> <p>FR Plaquettes en carbure à braser</p>	<p>IT Metallo duro per frese saldobrasate</p> <p>HU Vídia forrasztottlapkás szerszámokhoz</p>
	<p>EN Planer knives</p> <p>DE Hobelmesser</p> <p>FR Couteaux à raboter</p>	<p>IT Coltelli da pialla</p> <p>HU Gyalukések</p>
	<p>EN Knives for back corrugated cutterheads</p> <p>DE Messer für rückenverzahnte Messerköpfe</p> <p>FR Couteaux pour outils crantés</p>	<p>IT Coltelli per teste con zigrinatura</p> <p>HU Kések bordáshátú késfejekhez</p>
	<p>EN Rods</p> <p>DE Rundstäbe</p> <p>FR Barreaux cylindriques</p>	<p>IT Cilindri</p> <p>HU Rudak</p>
	<p>EN TIGRALloy products</p> <p>DE TIGRALloy Produkte</p> <p>FR Produits TIGRALloy</p>	<p>IT Prodotti TIGRALloy</p> <p>HU TIGRALLOY termékek</p>
	<p>EN PCD – Polycrystalline diamond</p> <p>DE PKD – Polykristalliner Diamant</p> <p>FR PCD – Diamant policristallin</p>	<p>IT PCD – Diamante policristallino</p> <p>HU PCD – Polikristályos gyémántok</p>





EN Technical data  
DE Technische Daten  
FR Caractéristiques techniques  
IT Dati tecnici  
HU Műszaki adatok



EN TIGRA carbide grades – Technical Data  
 DE TIGRA Hartmetallsorten – Technische Daten  
 FR Nuances carbure TIGRA – Caractéristiques techniques  
 IT I tipi di metallo duro TIGRA – Dati tecnici  
 HU TIGRA vidiakategóriák – Műszaki adatok

EN	TIGRA grade	Binder Binder Liant Legante Kötőanyag	Hardness		Bending strength		Toughness
			HV 10	HRA	N/mm <sup>2</sup>	psi	
T02SMG	ISO: K01 USA: C4 +++	2.5	2350	95.0 - 95.3	2000	290.000	5.7
T03SMG	ISO: K01 USA: C4 ++	3.5	2100	94.6	2600	377.000	7.5
T03MG-CR	ISO: K01 USA: C4 ++	3.0	2050	94.5	2500	363.000	7.8
T03F-CR	ISO: K01 USA: C4 +	3.0	1950	94.1	2300	334.000	8.0
T04MG-CR	ISO: K01 USA: C4 +	4.3	1900	93.8	2350	341.000	8.6
T04F-CR	ISO: K05 USA: C4	4.5	1800	93.3	2350	341.000	9.0
T05UMG	ISO: K01-K10 USA: C3 ++	5.0	2050	94.5	2450	355.000	7.8
T06MG	ISO: K01-K20 USA: C3 ++	6.0	1800	93.3	2700	392.000	8.4
T06F-CR	ISO: K10 USA: C3	6.0	1740	92.9	2350	341.000	8.9
T07MF-CR	ISO: K20-K30 USA: C2-C3	7.5	1580	91.7	2600	377.000	10.1
T07MF-W	ISO: K20-K30 USA: C2-C3	7.5	1540	91.5	2550	370.000	10.2
T10MG	ISO: K10-K40 USA: C3 +	10.0	1650	92.3	3700	537.000	10.0
T10MG-W	ISO: K10-K40 USA: C3 +	10.0	1600	92.0	3600	522.000	9.8
T12SMG	USA: C1 ++	12.0	1700	92.7	4000	580.000	9.5
T12M-CR	ISO: >K40 USA: C1	12.0	1200	88.3	2700	392.000	13.9
T15C	ISO: >K40 USA: Nail Cut	15.0	890	84.5	3000	435.000	> 20
TL15*	ISO: K10-K40 USA: C3 +	13.5	1450	90.8	3800	551.000	10.8
TL20*	ISO: K10-K40 USA: C2 +	20.0	1230	88.6	3700	537.000	> 20

CR = Co + Ni + Cr = corrosion resistant - korrosionsbeständig - anti-corrosif - inossidabile - korrózióálló  
 \* Special binder - Spezialbinder - Liant spécial - Legante speciale - Speciális kötőanyag

EN TIGRA carbide grades – Grain sizes and binder content  
 DE TIGRA Hartmetallsorten – Korngrößen und Bindergehalt  
 FR Nuances carbure TIGRA – Grosseur du grain et contingent de liant  
 IT I tipi di metallo duro TIGRA – Grossezza del grano e quota di legante  
 HU TIGRA vidiakategóriák – Szemcseméreték és kötőanyagtartalom

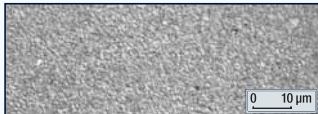
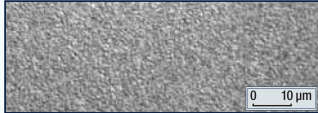
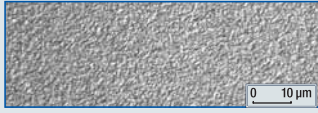
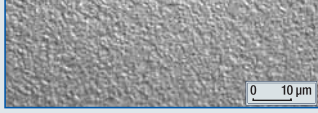
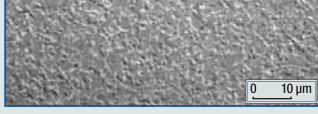
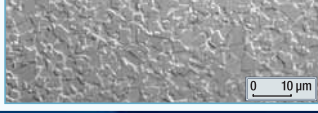
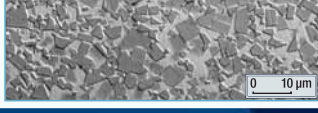
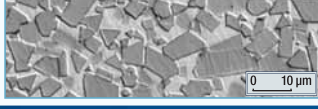
EN	Shortform	Explanation	Grain size	Micrograph
NG	Nanoszemcsés	0.2		
UMG	Ultra Mikroszemcsés	0.2 - 0.5		
SMG	Szub Mikroszemcsés	0.5 - 0.7		
MG	Mikroszemcsés	0.7 - 1.0		
F	Finomszemcsés	1.0 - 1.4		
MF	Közepesen finomszem.	1.4 - 2.5		
M	Közepes szemcsés	2.5 - 4.0		
C	Durvaszemcsés	4.0 - 10.0		
EC	Extradurvaszemcsés	> 10		

EN Detailed application recommendations can be found in the individual chapters.  
 DE Detaillierte Anwendungsempfehlungen finden Sie in den einzelnen Kapiteln.  
 FR Pour les recommandations d'application détaillées, veuillez voir aux chapitres suivants.  
 IT Suggestimenti di impiego dettagliati si trovano nei singoli capitoli.  
 HU Részletes ajánlásokat az alkalmazásokra az egyes fejezetekben talál.





EN TIGRALloy – Technical Data  
 DE TIGRALloy – Technische Daten  
 FR TIGRALloy – Caractéristiques techniques  
 IT TIGRALloy – Dati tecnici  
 HU TIGRALloy –Műszaki adatok

EN

TIGRALloy, a cutting material, consisting of a mixture of hard chromium and tungsten carbide that are embedded in a tough cobalt matrix. This results in an ideal combination of high hardness and high toughness.

Therefore TIGRALloy is an ideal cutting material for many kinds of solid wood. In addition to the good wear resistance, there is a high heat resistance. Very good brazability and the opportunity to grind extremely sharp cutting edges.

Characteristics:

Heat resistance: up to 800°C / 1500°F - Highly corrosion resistant - Extremely shock proof

Hardness: TL48: 48HRC - TL60: 60 HRC

DE

TIGRALloy besteht aus harten Chrom- und Wolframkarbiden, die in einer zähen Kobaltmatrix eingelagert sind. Daraus entsteht eine ideale Kombination von hoher Härte und besonders guter Zähigkeit. TIGRALloy ist damit ein idealer Schneidstoff für die Bearbeitung vieler Massivhölzer. Zu einer hohen Verschleißfestigkeit kommt eine hohe Hitzebeständigkeit, eine sehr gute Lötbarkeit und die Möglichkeit, mit sehr scharfen Schneidkanten zu arbeiten.

Eigenschaften:

Hitzebeständigkeit: bis 800°C - Sehr korrosionsbeständig - Hohe Bruchfestigkeit

Härte: TL48: 48HRC - TL60: 60 HRC

FR

TIGRALloy est constitué de carbures de chrome et de tungstène durs qui sont logés dans une matrice de cobalt résistante. TIGRALloy est ainsi un matériau de coupe idéal pour l'usage de nombreux bois massifs. Outre une grande résistance à l'usure, il présente également une forte résistance à l'échauffement, une excellente brasabilité et la possibilité de travailler avec des arêtes de coupe très vives.

Propriétés:

Résistance à la chaleur: jusqu'à 800°C - Très résistant à la corrosion - Grande résistance à la rupture

Dureté: TL48: 48HRC - TL60: 60 HRC

IT

TIGRALloy è composta da carburo duro di cromo e tungsteno, incastonati in una matrice di cobalto tenace. Una combinazione ideale di durezza e di resistenza.

TIGRALloy è oltretutto materiale ideale al taglio di molti tipi particolari di legno. La buona resistenza all'usura nonché la grande resistenza termica e una buona saldobrasatura permettono l'uso di taglienti molto affilati.

Caratteristiche:

Resistenza termica: fino a 800°C - Alta resistenza alla corrosione - Alta resistenza flessionale

Durezza: TL48: 48HRC - TL60: 60 HRC

HU







A TIGRALloy kemény króm- és wolframkarbidból áll, amelyek szívós kobalthálóba ötvözöttek. Ebből a nagy keménység és igen jó szívósság ideális kombinációja áll elő. Ezáltal a TIGRALLOY az ideális vágóanyag sok tömörfa megmunkálásához. A nagy kopásállósághoz nagy hőállóság, nagyon jó forraszthatóság és a nagyon éles vágóél lehetősége is társul.

Jellemzők:

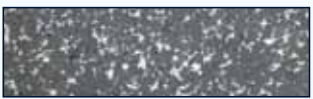
Hőállóság 800°C-ig - Nagy korrózióállóság - Nagy törésszilárdság

Keménység: TL48: 48HRC - TL60: 60 HRC

EN TIGRA PCD grades – Grain sizes and binder  
 DE TIGRA PKD-Sorten – Korngrößen und Binder  
 FR Nuances PCD TIGRA – Grosseur du grain et liant  
 IT I tipi di PCD TIGRA – Grossezza del grano e legante  
 HU TIGRA PCD kategóriák –Szemcseméreték és kötőanyag

EN	Shortform	Binder	Diamond content	Grain size	
DE	Abkürzung	Binder	Diamantgehalt	Korngröße	
FR	Abréviation	Liant	Teneur en diamant	Grosseur du grain	
IT	Abbreviazione	Legante	Contenuti diamante	Grossezza del grano	
HU	Rövidítés	Kötőanyag	Gyémánt tartalom	Szemcseméret	
				(µm)	
	FX	special	standard	2-4	
	MS	standard	standard	8-10	
	MS-W	standard	standard	8-10	
	MU+	ultrakemény	nagyon magas	2-4 + 8-10	
	MX+	special	standard	8-10	
	CU	ultrakemény	nagyon magas	2-4 + 20-35	
	CX	special	standard	20-35	

EN Detailed application recommendations can be found in the individual chapters.

DE Detaillierte Anwendungsempfehlungen finden Sie in den einzelnen Kapiteln.

FR Pour les recommandations d'application détaillées, veuillez voir aux chapitres suivants.

IT Suggestimenti di impiego dettagliati si trovano nei singoli capitoli.

HU Részletes ajánlásokat az alkalmazásokra az egyes fejezetekben talál.

EN TIGRA HSS materials – Technical Data  
 DE TIGRA HSS-Materialien – Technische Daten  
 FR Matériaux HSS TIGRA – Caractéristiques techniques  
 IT I materiali di HSS TIGRA – Dati tecnici  
 HU TIGRA HSS anyagok – Műszaki adatok



EN	Name	Main usage
DE	Name	Hauptverwendung
FR	Nom	Usage principal
IT	Nome	Uso principale
HU	Megnevezés	Üő alkalmazási terület
	HSS	EN Universal grade for soft and hardwood DE Universalsorte für Weich- und Hartholz FR Nuance universelle pour des bois tendres et durs IT Qualità universale per legni teneri e duri HU Univerzális kategória puha- és keményfához
	HSS 18 %	EN Abrasive and very hard woods DE Abrasive und sehr harte Hölzer FR Bois abrasifs et très durs IT Legni abrasivi e molto duri HU Koptató és nagyon kemény fákhoz
	HSS M42	EN Abrasive applications DE Abrasive Anwendungen FR Applications abrasives IT Applicazioni abrasive HU Koptató alkalmazások
	H.P.S.	EN Softwood, low price demands DE Weichholz, niedriger Preis FR Bois tendre, prix bas IT Legni teneri, prezzo ridotto HU Puhafához, alacsony árigenyek esetén

EN TIGRA coatings – Technical Data  
 DE TIGRA Beschichtungen – Technische Daten  
 FR Les revêtements TIGRA – Caractéristiques techniques  
 IT I rivestimenti TIGRA – Dati tecnici  
 ES Los rec





EN Matrix - coating technology:

Unique coating for maximum lifetime requirements

- Tool life is on average 3-5 times longer
- Coating penetrates into the material
- Still significantly longer tool life after resharpening
- Smoother surface

DE Matrix - coating technology:

Einzigartige Beschichtung für höchste Standwegansprüche

- Durchschnittlich 3-5-facher Standweg
- Beschichtung dringt in das Material ein
- Auch nach dem Nachschärfen noch deutlich längere Standwege
- Glattere Oberfläche

FR Matrix - coating technology:

Un revêtement unique pour une tenue d'outil inégalée

- En moyenne la tenue d'outil est multipliée par 3-5
- Le revêtement pénètre le matériau
- Des tenues d'outil nettement plus longues, même après le réaffûtage
- Surface plus lisse

IT Matrix - coating technology:

Rivestimento unico per esigenze di massima durata

- Una durata media 3-5 volte più lunga
- Il rivestimento penetra nel materiale
- Anche dopo la riaffilatura la durata è considerevolmente più lunga
- Superficie più liscia

HU Matrix -bevonat technológia:

Egyedülálló bevonat a maximális él(et)tartam igényekre

- A szerszám él(et)tartama az átlagosnál 3-5-ször több
- A bevonat behatol az anyagba
- Még újraélezést követően is jelentősen hosszabb él(et)tartam
- Simább felület

EN Detailed application recommendations can be found in the individual chapters.  
 DE Detaillierte Anwendungsempfehlungen finden Sie in den einzelnen Kapiteln.  
 FR Pour les recommandations d'application détaillées, veuillez voir aux chapitres suivants.  
 IT Suggestimenti di impiego dettagliati si trovano nei singoli capitoli.  
 HU Részletes ajánlásokat az alkalmazásokra az egyes fejezetekben talál.



EN TIGRA HSS Black Oxide – Technical Data  
 DE TIGRA HSS-Black Oxide – Technische Daten  
 FR HSS TIGRA Black Oxide – Caractéristiques techniques  
 IT HSS TIGRA Black Oxide – Dati tecnici  
 HU HSS TIGRA Black Oxide – Műszaki adatok

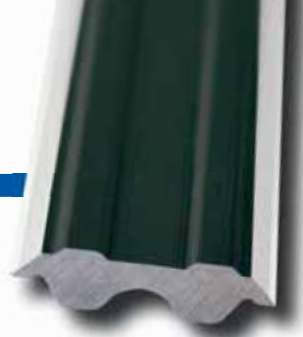
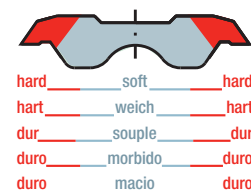

EN TIGRAMet - Heavy alloy tool body blanks – Technical Data  
 DE TIGRAMet - Grundkörperrohlinge aus Schwermetall – Technische Daten  
 FR TIGRAMet - Ébauches en métal lourd – Caractéristiques techniques  
 IT TIGRAMet - Corpo utensile grezzo in metallo pesante – Dati tecnici  
 HU TIGRAMet - Szerszámalaptest nyersdarabok nehézfémről – Műszaki adatok

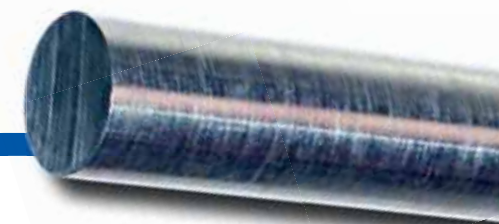

EN Optimized distribution of hardness  
 The unique manufacturing process maneuvers hardness to where it belongs: the cutting edge. The core of the knife remains soft to help protect against breakage and to also increase the ease of an eventual straightening.

#### Polished cutting edge

For an extra-aggressive cut in the wood, the cutting edge has a second, partial polish grind.

#### Black Oxide Surface

The thin black surface layer of ferric oxide, only nanometers thick, runs across the top and bottom. This improves corrosion resistance and prevents early rusting.

DE Optimierte Härteverteilung  
 Durch das spezielle Herstellungsverfahren wird die Härte genau dort hin gebracht, wo sie auch benötigt wird: in die Schneidkante. Der Kern des Messers bleibt weich und flexibel, was Bruch vorbeugt und das eventuelle Richten nach dem Nachschärfen vereinfacht.

#### Polierte Schneidkante

Für einen besonders giftigen Eingriff im Holz und eine sehr gute Holzoberfläche hat die Schneidkante einen zweiten, polierten Schliff.

#### Black Oxide Surface

Die wenige Nanometer starke, schwarze Schicht aus Eisenoxid auf Ober- und Unterseite macht das Messer beständiger gegen Korrosion und verhindert frühzeitiges Rosten.

FR Répartition optimale de la dureté  
 Grâce au procédé de fabrication spécial, la dureté est là où besoin en est: au niveau du tranchant. Le noyau du couteau reste souple et flexible, ce qui prévient la rupture et simplifie l'ajustement après le réaffûtage.

#### Tranchant poli

Le tranchant bénéficie d'un deuxième polissage, pour une coupe particulièrement nette et une très bonne surface de bois.

#### Surface Black Oxide

La couche noire en oxyde de fer, d'une épaisseur de quelques nanomètres sur le dessus et le dessous rend le couteau plus résistant contre la corrosion et la rouille anticipée.

IT Migliorata distribuzione della durezza  
 Grazie ad un particolare metodo di produzione, la durezza del coltello è là dove è maggiormente richiesta, sul tagliente. La parte centrale del coltello rimane più morbida e flessibile, si evitano così rotture e la riaffilatura è più semplice.

#### Tagliente parzialmente lappato

Per un taglio su legno più preciso e affilato, il tagliente è parzialmente lappato.

#### Superficie „Black Oxide“

La sottile superficie di ossido di ferro nero, rende il coltello più resistente alla corrosione e alla ruggine.

HU Optimális keménységeloszlás.  
 A speciális gyártási eljárás révén a keménység pontosan ott lesz, ahol arra szükség van: a vágóéleken. A kés magja lágy és rugalmas marad, ami megelőzi a törést és az újraélezés utáni esetleges egyenetlét egyszerűbbé teszi.

#### Polírozott vágóélek

A fa extra agresszív vágásához a vágóél egy második, polírozott köszörüléssel rendelkezik.

#### „Black Oxide“ felület

A néhány nanométer vastagságú fekete vasoxid réteg az alsó- és felső felületen a kést korrózióállóvá teszi, megakadályozva az idő előtti rozsdásodást.

EN TIGRAMet is a high density tungsten heavy alloy which is ideally suited for high stiffness tooling. TIGRA supplies pre-peeled heavy alloy rods with a high Young's modulus (elasticity). This also leads to a high absorption of vibration. Despite the high density (17g/cm<sup>3</sup>), it is still easy to machine. TIGRAMet has 40% less tendency to bend when compared to steel tool bodies. TIGRAMet is available from stock in many dimensions.

#### Your benefits:

- high stiffness
- less vibrations
- cut-to-size available
- large stock
- favorable pricing
- special dimensions upon request

DE TIGRAMet ist ein hochdichtes Schwermetall auf Wolframbasis, welches ideal für Werkzeuge mit großen Steifigkeitsansprüchen geeignet ist. TIGRA liefert vorgeschälte Schwermetall-Rundstäbe mit hohem Elastizitätsmodul. Dies führt zu stark gedämpften Schwingungen. Trotz der Dichte von 17 g/cm<sup>3</sup> lässt sich TIGRAMet noch gut zerspanen und reduziert die Durchbiegung im Vergleich zu Stahlgrundkörpern um 40%. TIGRAMet ist in vielen Abmessungen ab Lager verfügbar.

#### Ihre Vorteile:

- hohe Steifigkeit
- geringe Vibrationen
- Fixlängen lieferbar
- großes Lager
- günstige Preise
- Sonderabmessungen auf Anfrage

FR TIGRAMet est un métal lourd haute densité à base de tungstène, qui convient idéalement aux outils à exigences élevées en terme de rigidité. TIGRA fournit des barreaux cylindriques pré-brasés en métal lourd à module d'élasticité élevé. Cela conduit à des oscillations fortement amorties. Malgré une densité égale à 17 g/cm<sup>3</sup>, TIGRAMet reste encore facile à usiner et réduit la flexion de 40 % comparativement à des corps de base en acier. TIGRAMet est disponible sur stock en différentes dimensions.

#### Vos avantages:

- une rigidité élevée
- des vibrations réduites
- des longueurs spécifiques sur demande
- un large stock
- des prix bas
- des dimensions spéciales disponibles sur demande

IT TIGRAMet è un metallo pesante ad alta densità a base di tungsteno, ideale per utensili con esigenze di rigidità. TIGRA fornisce cilindri pelati in metallo pesante con elevato modulo di elasticità. Ciò permette di avere oscillazioni estremamente attenuate. Nonostante la densità di 17 g/cm<sup>3</sup>, TIGRAMet è facilmente lavorabile e riduce la flessione del 40% rispetto alle basi in acciaio. TIGRAMet è disponibile franco magazzino in molte misure.

#### I vostri vantaggi:

- elevata rigidità
- vibrazioni minime
- disponibile in lunghezze fisse
- ampia disponibilità
- prezzi vantaggiosi
- misure particolari su richiesta

HU A TIGRAMet egy igen nagy sűrűségű wolframalapú nehézfém, amelyik nagy merevségigényű szerszámokhoz ideálisan alkalmas. A TIGRA nagy rugalmassági modulusú előnagytöltött nehézfémrudakat szállít. Ez erősen lecsökkentett rezgéseket eredményez. A 17g/cm<sup>3</sup> sűrűség ellenére a TIGRAMet jól forgácsolható és egy acél alaptesthez képest 40%-kal csökkenti a behajlást. A TIGRAMet sokféle méretben raktárról kapható.

#### Az Ön előnyei

- nagy merevség
- minimális vibráció
- méretre vágva szállítható
- nagy raktárkészlet
- jutányos árak
- különleges méretek igény szerint



### EN TIGRA – Quality Leader worldwide

TIGRA's self-designed, highly automated production machines guarantee 100% optically controlled precision products that are delivered to the customer at an optimal price-performance ratio in a short time. In close co-operation with the tool manufacturers, TIGRA develops optimally coordinated cutting geometries and grades resulting in long tool life and significant cost reductions. No matter if it's about standard or special products: TIGRA is the competent partner for versatile solutions of carbide and ultra-hard cutting materials for a variety of woodworking tools. In order to always meet the application requirements of the customer and to optimize the tool efficiency in the best possible way, TIGRA is placing special emphasis on innovation and continuous improvement in the production of the various cutting inserts.

### DE TIGRA – Weltweiter Qualitätsführer

TIGRA's selbst konstruierte, hoch automatisierte Fertigungsmaschinen garantieren 100% optisch kontrollierte Präzisionsprodukte, die zu einem optimalen Preis-Leistungsverhältnis in kurzer Zeit dem Kunden geliefert werden. In enger Zusammenarbeit mit den Werkzeugherstellern entwickelt TIGRA optimal abgestimmte Schneidgeometrien und -güten, die lange Werkzeugstandwege und erhebliche Kostenreduzierungen mit sich bringen. Ob Standard- oder Sonderartikel: TIGRA ist der kompetente Partner für vielseitige Lösungen aus Hartmetall und ultraharten Schneidstoffen für die verschiedensten Werkzeuge der Holzbearbeitung. Um den Anwendungsbedürfnissen der Kunden stets gerecht zu werden und die Werkzeugeffizienz möglichst zu optimieren, werden Innovation und permanente Verbesserung bei der Fertigung der unterschiedlichsten Schneideinsätze im Hause TIGRA groß geschrieben.

### FR TIGRA – leader mondial en terme de qualité

La société TIGRA conçoit elle-même ses machines de production hautement automatisées. Celles-ci sont le gage de produits de précision faisant l'objet de contrôles visuels 100 %, pour un rapport qualité-prix optimal et un délai de livraison court. En étroite collaboration avec des fabricants d'outils, TIGRA développe des géométries et des qualités de coupe parfaitement ajustées, qui garantissent la longue durée de vie des outils et des réductions considérables des coûts. Produits standards ou spéciaux: TIGRA est votre partenaire compétent pour des solutions de coupe polyvalentes en carbure (métal dur) et en matériaux de coupe ultra-durs pour les outils les plus divers dédiés au travail du bois. Afin de répondre aux exigences d'application du client et optimiser le plus possible l'efficacité de l'outil, TIGRA place au premier plan l'innovation et l'amélioration continue lors de la fabrication des plaquettes de coupe les plus diverses.

### IT TIGRA – Leader mondiale della qualità

Le apparecchiature di produzione costruite dall'azienda stessa ed altamente automatizzate, garantiscono prodotti di precisione controllati al 100% a livello ottico, consegnati al cliente con un ottimo rapporto qualità prezzo e in breve tempo. Collaborando a stretto contatto con i produttori di utensili, TIGRA sviluppa geometrie di taglio e qualità di metallo duro perfettamente sintonizzate l'uno all'altro permettendo agli utensili di durare nel tempo e riducendo notevolmente i costi. Articoli standard o particolari, non c'è differenza: TIGRA è il partner competente per molteplici soluzioni in metallo duro e per materiali da taglio ultraduri per i diversi utensili per la lavorazione del legno. Per soddisfare costantemente le esigenze di applicazione dei clienti e ottimizzare quanto più possibile l'efficienza degli utensili, l'innovazione e il miglioramento nella produzione della vasta gamma di placchette assumono un ruolo di primaria importanza nell'azienda TIGRA.

### HU TIGRA – Világszerte élen a minőségben

A TIGRA saját konstrukciójú, magasan automatizált gyártósorai 100%-ban szemrevételezett precíziós termékeket garantálnak, amelyeket optimális ár-teljesítményarányosan rövid időn belül az ügyfeleknek kiszállítunk. A TIGRA a szerszámgyártókkal szoros együttműködésben olyan optimálisan meghatározott vágóél-geometriát és -termékeket fejleszt ki, amelyek hosszú szerszámél(et)tartamot és jelentős költségcsökkentést hoznak magukkal. Akár szokványos vagy egyedi termék, a TIGRA kompetens partner sokoldalú megoldásokra vídiából és ultrakemény vágóanyagokból a famegmunkálás legkülönbözőbb szerszámaihoz. Az ügyfelek felhasználási igényeinek folyamatosan szem előtt tartásához a TIGRÁNÁL az innováció és a különféle vágóeszközök gyártásának folyamatos javítása nagy betűvel írt.







### EN TIGRA – Short portrait of a forward-looking company

TIGRA is a leading supplier of cutting inserts made of tungsten carbide, HSS, TIGRALloy, PCD and PCBN for wood and metal working tools as well as for tungsten carbide special knives and wear parts. Thanks to the highly automated production and an internationally structured distribution network TIGRA today offers the most extensive product range for woodworking in the global market. No matter if it is chipboard, MDF / HDF or all types of natural woods, TIGRA products made of specially developed carbide grades as well as of other materials such as HSS, PCD, TIGRALloy ensure optimum tool life, break resistance and best cutting results.

### DE TIGRA – Kurzporträt eines zukunftsorientierten Unternehmens

TIGRA ist ein führender Lieferant von Schneideinsätzen aus Hartmetall, HSS, TIGRALloy, PKD und PcBN für Holz- und Metallbearbeitungswerkzeuge sowie für Hartmetall-Spezialmesser und -Verschleißteile. Dank der hochautomatisierten Fertigung und einem international strukturierten Vertriebsnetz bietet TIGRA heute das umfangreichste Produktprogramm für die Holzbearbeitung am Weltmarkt an. Ob Spanplatte, MDF/HDF oder alle Arten von natürlichen Hölzern, TIGRAs Produkte aus speziell entwickelten Hartmetallsorten sowie aus weiteren Werkstoffen wie HSS, PKD, TIGRALloy sorgen für optimale Standwege, Bruchsicherheit und beste Schnittergebnisse.

### FR TIGRA – Court portrait d'une entreprise tournée vers l'avenir

TIGRA est un fournisseur leader de plaquettes de coupe en métal dur, HSS, TIGRALloy, PCD et PcBN destinées aux outils de travail du bois et du métal et aux couteaux spéciaux et pièces d'usure en carbure. Grâce à une production automatisée high-tech et un réseau de vente présent à l'international, TIGRA propose aujourd'hui sur le marché mondial une vaste gamme de produits dédiée au travail du bois. Pour les panneaux à particules, MDF/HDF ou d'autres essences de bois naturels, TIGRA développe des produits de coupe en carbure spécial ou autres matériaux tels que le HSS, PCD, TIGRALloy qui assurent une excellente tenue d'outil, une résistance élevée à la rupture et des résultats de coupe parfaits.

### IT TIGRA – Breve ritratto di un'azienda orientata al futuro

TIGRA è tra i fornitori leader di placchette in metallo duro, HSS, TIGRALloy, PCD e PcBN per utensili per la lavorazione del legno e del metallo, per coltelli speciali in metallo duro e per il settore usura. Grazie all'elevata automazione nella produzione e ad una rete di vendita internazionale, TIGRA offre oggi la gamma più completa sul mercato mondiale di prodotti per la lavorazione del legno. Sia che si tratti di truciolare, MDF/HDF o di tutte le varietà di legni naturali, i prodotti TIGRA in diversi tipi di metallo duro sviluppati per le specifiche produttive o in altri materiali come HSS, PCD, TIGRALloy, garantiscono longevità ottimale, resistenza alla rottura e le migliori performance di taglio.

### HU TIGRA –Egy jövőorientált vállalat rövid bemutatása

A TIGRA vadia, HSS, TIGRALLOY, PCD és PCBN anyagokból készített vágóeszközök vezető szállítója fa- és fémmegmunkáló szerszámokszerszámokhoz, valamint egyedi vídiakések és kopó alkatrészek gyártója. A magasan automatizált gyártásnak és egy nemzetközileg felépített értéértékesítési hálózatnak köszönhetően a TIGRA a legátfogóbb termékínálattal rendelkezik a famegmunkáláshoz a világpiacon. Akár rétegelt lemez, MDF/HDF vagy bármilyen fajtájú természetes fa, a TIGRA speciálisan kifejlesztett vídiafajtákból, valamint további olyan anyagok anyagokból, mint HSS, PCD, TIGRALLOY készített termékei optimális él(et)tartamot, törésszilárdságot és nagyon jó vágási eredményt biztosítanak.



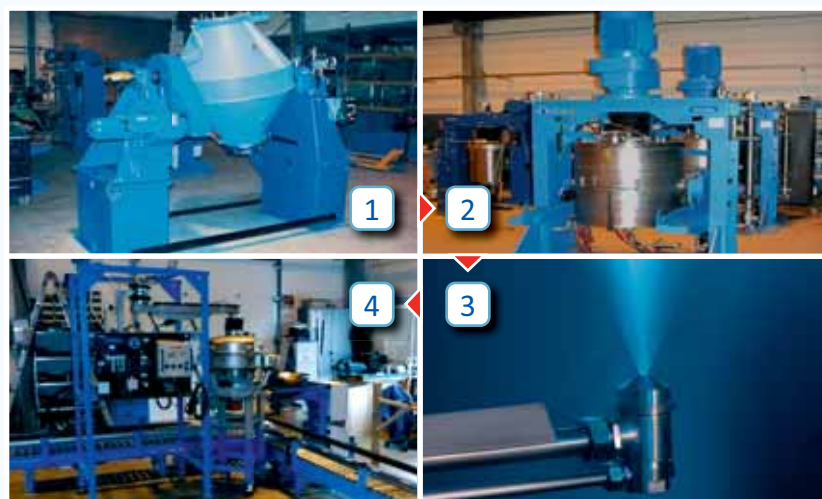

Powder manufacturing  
 Porkeverék gyártása

- |                        |                                  |
|------------------------|----------------------------------|
| 1. Mixing<br>Keverés   | 2. Milling<br>Örlés              |
| 4. Sieving<br>Szitálás | 3. Spray drying<br>Fújvaszárítás |

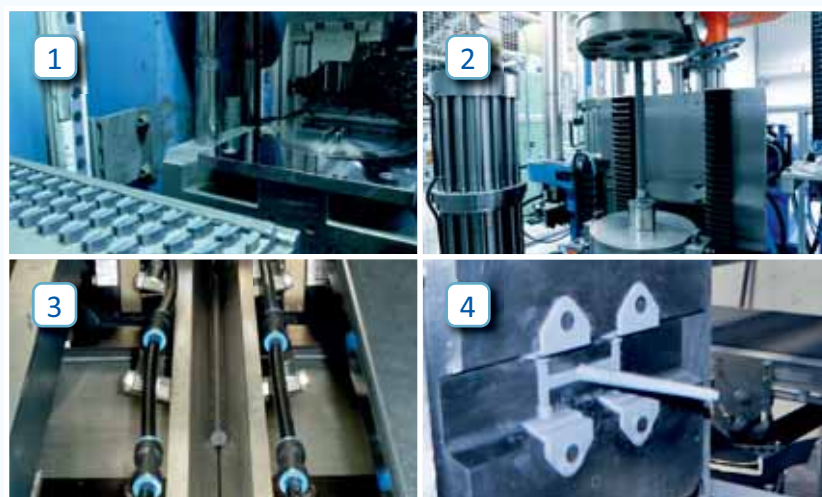

Pressing  
 Préselés

- |   |  |
|---|--|
| 1. Uniaxial pressing<br>Egytengelyű préssel | 2. Isostatic pressing<br>Izosztatikus préselés |
| 3. Extrusion pressing<br>Rúdsajtolás        | 4. Injection molding<br>Fröccsöntés            |

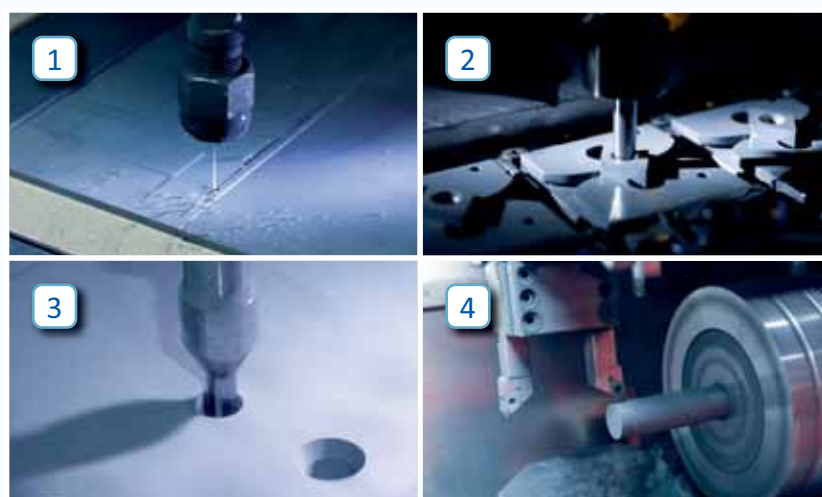

Green carbide processing  
 Nyersvídia megmunkálás

- |                         |                           |
|-------------------------|---------------------------|
| 1. Cutting<br>Darabolás | 2. Drilling<br>Fúrás      |
| 3. Milling<br>Marás     | 4. Turning<br>Forgácsolás |

Sintering  
 Szinterezés

- |  |  |
|--|--|
| 1. Pressure sintering<br>Présszinterezés | 2. Vacuum sintering<br>Vákuumszinterezés |
|--|--|



Surface treatment  
 Felületkezelés

- |                                |                           |
|--------------------------------|---------------------------|
| 1. Sand blasting<br>Homokfúvás | 2. Coating<br>Bevonatolás |
|--------------------------------|---------------------------|



Grinding  
 Köszörülés

- |                                   |                                  |
|-----------------------------------|----------------------------------|
| 1. Flat grinding<br>Síkköszörülés | 2. Edge grinding<br>Élköszörülés |
|-----------------------------------|----------------------------------|



Quality control  
 Minőségellenőrzés

- |                        |                                   |
|------------------------|-----------------------------------|
| 1. Analysis<br>Elemzés | 2. Dimensional<br>Méretellenőrzés |
|------------------------|-----------------------------------|



Packing and shipping  
 Csomagolás és szállítás

- |                          |                            |
|--------------------------|----------------------------|
| 1. Packing<br>Csomagolás | 2. Shipping<br>Kiszállítás |
|--------------------------|----------------------------|











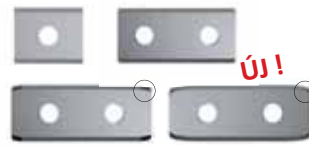



EN Reversible knives and edge rounding knives  
DE Wendeschneidplatten und Kantenrunder  
FR Plaquettes réversibles et couteaux brise-arrête  
IT Coltelli reversibili e spigolatori  
HU Cserelapkák és éllekerekítő kések

- EN Reversible knives and edge rounding knives  
 DE Wendeschneidplatten und Kantenrunder  
 FR Plaquettes réversibles et couteaux brise-arrête  
 IT Coltelli reversibili e spigolatori  
 HU Cserelapák és éllekerekítő kések

	EN Standard reversible knives 35° + 45° DE Standard Wendeschneidplatten 35° + 45° FR Plaquettes réversibles standard 35° + 45° IT Coltelli reversibili standard 35° + 45° HU Standard váltólapkák 35° + 45°	24 - 26
	EN Reversible knives DE Wendeschneidplatten FR Plaquettes réversibles IT Coltelli reversibili HU Váltólapkák	27
	EN Square knives DE Quadratische Wendeschneidplatten FR Plaquettes réversibles à quatre coupes IT Coltelli reversibili quadrati HU Négyzetű váltólapkák	28 - 30
	EN Spurs, grooving knives DE Vorschneider, Nuter FR Araseur, couteaux pour rainures IT Rasanti, coltelli per incastri HU Elővágók, horonyvágók	31
	EN 4 cutting edges / special knives DE 4 Schneidkanten / Sondermesser FR 4 tranchants / couteaux spéciaux IT 4 taglienti / coltelli speciali HU 4 vágóélű / speciális kések	32
	EN Face groove, back groove and crossgroove DE Brust-, Rücken- und Quernut FR Rainure sur grande face, sur petite face et transversal IT Scanalatura frontale, posteriore e di sicurezza HU Homlok-, hát- és keresztbarázdás kések	33
	EN Systems Leitz, Oertli, KWO/Versofix DE Systeme Leitz, Oertli, KWO/Versofix FR Systèmes Leitz, Oertli, KWO/Versofix IT Sistemi Leitz, Oertli, KWO/Versofix HU Leitz, Oertli, KWO/Versofix rendszerek	34 - 35
	EN Edge rounding knives DE Kantenrunder FR Couteaux brise-arrête IT Spigolatori HU Éllekerekítő és életörő kések	36
	EN PCD reversible Knives DE PKD-Wendeschneidplatten FR Plaquettes réversibles PCD IT Coltelli reversibili PCD HU DIA (PCD) váltólapkák	37



EN Reversible knives – Carbide grades and their applications  
 DE Wendeschneidplatten – Hartmetallsorten und ihre Anwendungen  
 FR Plaquettes réversibles – Les nuances de carbures et leurs applications  
 IT Coltelli reversibili – I tipi di metallo duro e le loro applicazioni  
 HU Váltólapkák – Vídia kategóriák és felhasználásuk

EN DE FR IT HU	TIGRA grade TIGRA - Sorte Nuance TIGRA Tipo TIGRA TIGRA kategória	ISO ISO ISO ISO ISO	USA USA USA Stati uniti EE.UU.	Hardness Härte Dureté Durezza Keménység	Toughness Zähigkeit Ténacité Tenacità Szívósság	Bending strength Biegebruchfestigkeit Résistance à la flexion Resistenza flessionale Hajlítószilárdság	Plastics Plastik Plastiques Plastica Műanyag	HDF HDF HDF HDF HDF	MDF MDF MDF MDF MDF	Chipboard Spanplatte Panneaux de particule Truciolare Forgácslap	Hardwood Hartholz Bois dur Legno duro Keményfa	Softwood Weichholz Bois tendre Legno tenero Puhafa	Main usage Hauptverwendung Usage principal Uso principale Fő alkalmazási terület
	T02SMG	K01	C4+++	↑	↘	↓	✓	✓	✓	○	☒	☒	EN MDF, HDF DE MDF, HDF FR MDF, HDF IT MDF, HDF HU MDF, HDF
	T03SMG	K01	C4++	↗	↘	→	✓	✓	✓	✓	☒	☒	EN Chipboard, MDF DE Spanplatte, MDF FR Panneaux, MDF IT Truciolare, MDF HU Forgácslap, MDF
	T04MG-CR	K01	C4+	→	→	→	✓	○	✓	✓	✓	○	EN Tropical wood, very hard wood, chipboard, MDF DE Tropenholz, sehr hartes Holz, Spanplatte, MDF FR Bois tropical, bois très dur, panneaux, MDF IT Legni tropicali, legni molto duri, truciolare, MDF HU Trópusi fa, nagyon kemény fa, forgácslap, MDF
	T04F-CR UNIVERSAL	K05	C4	→	↗	→	✓	○	✓	✓	✓	✓	EN Universal use DE Universeller Einsatz FR Utilisation universelle IT Uso universale HU Univerzálisan alkalmazható
	T05UMG	K01 - K10	C3++	↗	↘	↗	✓	☒	○	☒	✓	✓	EN Special reversible knives DE Spezial-Wendeschneidplatten FR Plaquettes réversibles spéciales IT Coltelli reversibili speciali HU Speciális váltólapkák
	T07MF-CR	K20 - K30	C2 - C3	↘	↑	↗	☒	☒	☒	☒	✓	✓	EN Grooving knives DE Nuter FR Couteaux pour rainures IT Coltelli per incastri HU Horonyvágók
	T10MG	K10 - K40	C3+	↗	↗	↑	○	☒	☒	☒	✓	✓	EN 45° reversible knives, planer knives, softwood DE 45°-Wendeschneidplatten, Hobelkopffplatten, Weichholz FR Plaquettes 45°, couteaux pour outils à raboter, bois tendre IT Coltelli a 45°, coltelli per teste da pialla, legni teneri HU 45°-os váltólapkák, gyalukések, puhafához
	T10MG-W	K10 - K40	C3+	↗	↗	↗	☒	☒	☒	☒	✓	✓	EN Wood, low price demands DE Holz, niedriger Preis FR Bois, prix bas IT Legno, prezzo ridotto EU Fa, alacsony árigenynél
	T12SMG		C1++	↗	↑	↑	☒	☒	☒	☒	✓	✓	EN Best surface, high speed cutting (HSC) DE Beste Oberfläche, HSC FR Meilleure surface, HSC IT Migliore superficie, HSC HU Legsimább felület, nagy sebességű vágás (HSC)
	TL15*	K10 - K40	C3+	↗	↑	↑	○	☒	☒	☒	✓	✓	EN 45° reversible knives, wood with knots, softwood DE 45°-Wendeschneidplatten, Holz mit Ästen, Weichholz FR Plaquettes 45°, bois avec des noeuds, bois tendre IT Coltelli a 45°, legni nodosi, legno tenero HU 45°-os váltólapkák, csomós puhafához

CR = Co + Ni + Cr = corrosion resistant - korrosionsbeständig - anti-corrosif - inossidabile - korrozóálló

\* Special binder - Spezialbinder - Liant spécial - Legante speciale - Speciális kötőanyag

EN For technical data, please refer to the pages 4-5.  
 DE Die technischen Daten entnehmen Sie bitte den Seiten 4-5.  
 FR Pour les données techniques, veuillez voir aux pages 4-5.

IT Per i dati tecnici, fare riferimento alle pagine 4-5.  
 HU A műszaki adatokat a 4-5. oldalon találja.

✓ kiváló teljesítőképesség ○ elfogadható  
 ✓ nagyon jó teljesítményű ☒ nem alk. ble

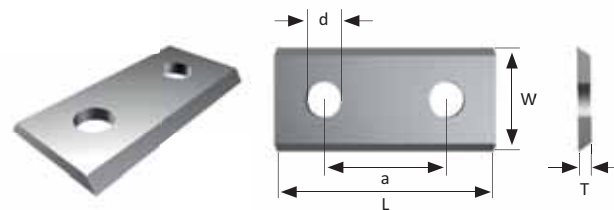

35°

- EN Standard reversible knives
- DE Standard-Wendeschneidplatten
- FR Plaquettes réversibles standard
- IT Coltelli reversibili standard
- HU Standard váltólapkák

	L mm	W mm	T mm	a mm	T04F-CR	T02SMG	T03SMG	T04MG-CR	T10MG	T10MG-W
	7.5	12.0	1.5		012001		013811	106822	013963	142721
	8.6	12.0	1.5		013182					
	9.0	12.0	1.5		012043					
	9.6	12.0	1.5		012015		013850	106823	014010	142722
	10.0	12.0	1.5		013165					
	10.5	12.0	1.5		013167					
	11.0	12.0	1.5		013168					
	11.6	12.0	1.5		013183					
	13.0	12.0	1.5		013170					
	13.6	12.0	1.5		013185					
	14.6	12.0	1.5		013186					
	15.0	12.0	1.5		012003	052277	013819	106824	013972	142723
	15.7	12.0	1.5		013172					
	16.0	12.0	1.5		013203					
	17.0	12.0	1.5		013173					
18.0	12.0	1.5		013174						
19.0	12.0	1.5		013175						
20.0	12.0	1.5		012004	041587	013823	104796	013977	127452	
25.0	12.0	1.5		012025	112368	013853	106826	014013	142975	
	25.0	12.0	1.5	14.0	012011		013843	106827	014001	152428
	30.0	12.0	1.5	14.0	012005	037750	013828	104795	013982	125424
	35.0	12.0	1.5	26.0	013208					
	40.0	12.0	1.5	26.0	012014	052278	013847	106828	014006	127453
	50.0	12.0	1.5	26.0	012006	037901	013834	106829	013987	125425
	60.0	12.0	1.5	26.0	012007	054882	013839	106830	013994	127454

	L mm	W mm	T mm		T04F-CR
	30.0	12.0	2.5	35°	054259

	L mm	W mm	T mm	a mm	T07MF-CR	T03SMG	T04MG-CR	T10MG	T10MG-W
	80.0	13.0	2.2	60.0	012008	013841	106831	013997	152430
	100.0	13.0	2.2	60.0	012009	030831	106832	013998	152431
	120.0	13.0	2.2	60.0	012010	030832	106833	013999	152432

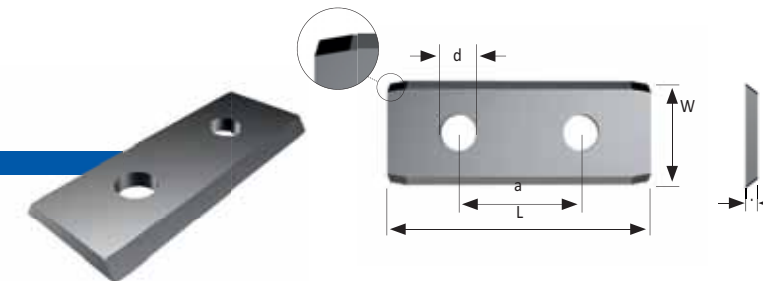

- EN Reversible knives
- DE Wendeschneidplatten
- FR Plaquettes réversibles
- IT Coltelli reversibili
- HU Váltólapkák

For use in planer heads!  
Gyalufejekhez!

Lesarkított éllel	L mm	W mm	T mm		T04F-CR	T04MG-CR	T10MG
	20.0	12.0	1.5	35°		106674	013979
	20.0*	12.0	1.5	45°			041948
	24.0	12.0	1.5	40°	104119	106675	041060
	24.7	12.0	1.5	35°	104120	106676	
	30.0	12.0	1.5	35°	112875	106677	013984
	50.0	12.0	1.5	35°			013989
	30.0	12.0	2.5	35°	102283		

\* EN System Hundegger  
\* DE System Hundegger  
\* FR Système Hundegger  
\* IT Sistema Hundegger  
\* HU Hundegger rendszerű



New edge technology - Rounded cutting edges for high-quality wood surfaces  
 Neue Kantentechnologie - Abgerundete Schneidkanten für hochwertige Holzoberflächen  
 Nouvelle technologie des lames - Bords de coupe arrondis pour des surfaces en bois de haute qualité  
 Nuova tecnologia dei bordi: bordi arrotondati per superfici in legno di alta qualità  
 Új éltechnológia - Lekerekített vágóél a magas minőségű fafelületért

Lekerekített él

l = EN Effective working length  
 DE Nutzlänge  
 FR Longueur utile de travail  
 IT Lunghezza utile di lavoro  
 HU Tényleges munkahossz

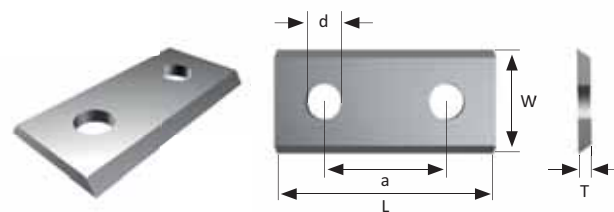

Lekerekített éllel	L mm	W mm	T mm		l mm	T04F-CR	T10MG
	30.0	12.0	1.5	35°	20	161015	161554



45°

EN Reversible knives  
 DE Wendeschneidplatten  
 FR Plaquettes réversibles  
 IT Coltelli reversibili  
 HU Váltólapkák

**POLÍROZOTT**







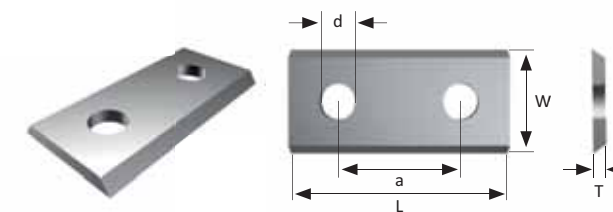

	L mm	W mm	T mm	a mm		T10MG
	9.6	12.0	1.5		45°	014117
	15.0	12.0	1.5		45°	014099
	20.0	12.0	1.5		45°	014101
	25.0	12.0	1.5	14.0	45°	014111
	30.0	12.0	1.5	14.0	45°	014103
	40.0	12.0	1.5	26.0	45°	014114
	50.0	12.0	1.5	26.0	45°	014106
	60.0	12.0	1.5	26.0	45°	014108
	12.0	12.0	1.5		45°	014097



**NEM POLÍROZOTT**

	L mm	W mm	T mm	a mm		T07MF-CR	T10MG
	7.5	12.0	1.5		45°		014091
	9.6	12.0	1.5		45°		014115
	15.0	12.0	1.5		45°		014098
	20.0	12.0	1.5		45°		014100
	25.0	12.0	1.5		45°		014123
	25.0	12.0	1.5	14.0	45°		014110
	30.0	12.0	1.5	14.0	45°		014102
	40.0	12.0	1.5	26.0	45°		014113
	50.0	12.0	1.5	26.0	45°		014105
	60.0	12.0	1.5	26.0	45°		014107
	12.0	12.0	1.5		45°		014096
	80.0	13.0	2.2	60.0	45°	013532	038233



EN Reversible knives  
 DE Wendeschneidplatten  
 FR Plaquettes réversibles  
 IT Coltelli reversibili  
 HU Váltólapkák



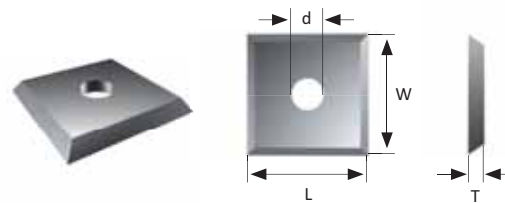

	L mm	W mm	T mm	a mm		T04F-CR
	20.0	14.3	2.5			013730
	44.5	15.0	1.5	25.0		013447
	30.0	12.0	1.5	16.0		013449
	24.0	12.0	1.5			013241
	30.0	12.0	1.5	14.0		013430
	30.0	12.0	1.5	14.0		013431
	30.0	12.0	1.5	14.0		013437
	40.0	12.0	1.5	26.0		013440
	50.0	12.0	1.5	26.0		013438
	30.0	12.0	1.5	14.0		013442
	40.0	12.0	1.5	26.0		013445
	50.0	12.0	1.5	26.0		013443

	L mm	W mm	T mm	a mm		T04F-CR
	20.0	9.0	1.5			013195
	30.0	9.0	1.5	14.0		013199
	40.0	9.0	1.5	26.0		013200
	50.0	9.0	1.5	26.0		013201





EN Square knives  
 DE Quadratische Wendeschneidplatten  
 FR Plaquettes réversibles à quatre coupes  
 IT Coltelli reversibili quadrati  
 HU Négyszöglapkák

	L	W	T		d	T07MF-CR	T04F-CR	T02SMG	T03SMG	T04MG-CR	T10MG	T10MG-W
	mm	mm	mm		mm							
	9.0	9.0	1.5	35°	4.0		100744					
	10.5	10.5	1.5	35°	4.0		013259		013863			
	12.0	12.0	1.5	35°	4.0		012002	048357	013815	106835	013968	140093
	13.0	13.0	2.5	35°	4.0		013328					
	17.0	17.0	2.0	35°	3.0		016564					
	17.0	17.0	2.0	35°	4.0		013265					
	19.0	19.0	2.0	35°	4.0		013264					
	10.5	10.5	1.5	35°						106682		
	13.0	13.0	2.5	30°		013324						
	13.6	13.6	2.0	30°		013299						
	13.6	13.6	2.0	45°		037522						
	14.0	14.0	1.2	30°		013295						
	14.0	14.0	1.7	30°		013307						
	14.0	14.0	2.0	30°		013273	013260	054962	013865	102558	014028	140094
 For Holz-Her system*	14.0	14.0	1.2	30°		013303						
	15.0	15.0	2.0			013322						

\* EN For use in Holz-Her cutterheads only  
 \* DE Nur zur Verwendung in Messerköpfen der Firma Holz-Her  
 \* FR Utilisation limitée aux porte outils de l'entreprise Holz-Her  
 \* IT Da usare solo su teste portacoltelli della Holz-Her  
 \* HU Csak Holz-Her gyártmányú késfejekben használható

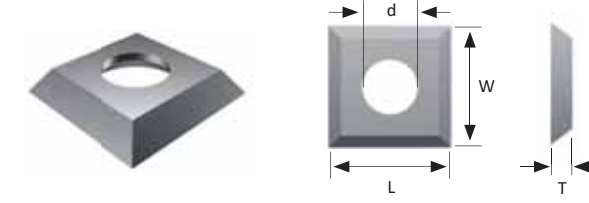

EN Square knives  
 DE Quadratische Wendeschneidplatten  
 FR Plaquettes réversibles à quatre coupes  
 IT Coltelli reversibili quadrati  
 HU Négyszöglapkák

For use in planer heads!  
 Gyalufejekhez!

Egyenes éles sarokkal	L	W	T		T07MF-CR	T04F-CR	T10MG	T04MG-CR	TL15	T10MG-W
	mm	mm	mm							
	10.5	10.5	1.5	35°				106682	040343	
	14.0	14.0	2.0	30°	013273	013260	014028	102558	013771	140094
	14.0	14.0	2.0	37°			104900			
	14.3	14.3	2.5	35°			013329	106683		
	14.6	14.6	2.5	30°			013314	106684		
	15.0	15.0	2.5	30°			013315	106685		152429
	15.0	15.0	2.5	37°			104062			
Egyenes kerek sarokkal	L	W	T		T07MF-CR	T10MG				
	mm	mm	mm							
	14.0	14.0	2.0	30°	013276	104117				
	14.6	14.6	2.5	30°		013316				
	15.0	15.0	2.5	30°		104118				
	15.0	15.0	2.5	37°		109384				
Ledinek* rendszerű	L	W	T			T10MG				
	mm	mm	mm							
	14.3	14.3	2.5	35°		053589				
	14.3	14.3	2.5	35°		053590				
	14.3	14.3	2.5	35°		106861				
	L	W	T		T10MG	TL20	T10MG-W			
	mm	mm	mm							
	21.0	21.0	5.5	40°	022695	142724	140092			

\* EN For use in Ledinek-cutterheads only  
 \* DE Nur zur Verwendung in Messerköpfen der Firma Ledinek  
 \* FR Utilisation limitée aux porte outils de l'entreprise Ledinek  
 \* IT Da usare solo su teste portacoltelli della Ledinek  
 \* HU Csak a Ledinek cég késfejeiben használható

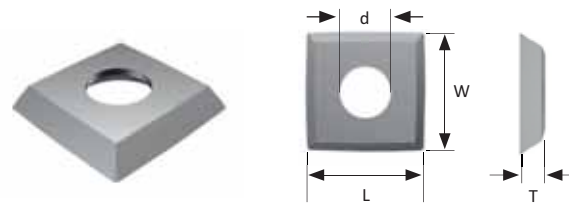

EN Square knives  
 DE Quadratische Wendeschneidplatten  
 FR Plaquettes réversibles à quatre coupes  
 IT Coltelli reversibili quadrati  
 HU Négyszöglapkák

For use in planer heads!  
 Gyalufejekhez!

Rádiuszos vágóél kerek sarokkal	L mm	W mm	T mm	R		T10MG	T10MG-W
	11.0	11.0	1.5	R=50	40°	140519	
	15.0	15.0	2.5	R=115	30°	115179	
	15.0	15.0	2.5	R=150	30°	101540	140096

	L mm	W mm	T mm	R		T10MG	T10MG-W
	14.0	14.0	2.0	R=150	30°	100788	
	13.8	13.8	2.5	R=40	37°	154645	
	15.0	15.0	2.5	R=50	30°	043895	140095
	15.0	15.0	2.5	R=180	30°	129329	
	15.0	15.0	2.5	R=200	30°	118997	

Rádiuszos vágóél hegyes sarokkal	L mm	W mm	T mm	R		T04MG-CR	T10MG
	15.0	15.0	2.5	R=170	40°		130366
	15.0	15.0	2.5	R=190	40°		147537
	15.0	15.0	2.5	R=200	30°	130828	
	15.0	15.0	2.5	R=95	30°		148426
	15.0	15.0	2.5	R=95	37°		148427
	15.0	15.0	2.5	R=100	30°		101180
	15.0	15.0	2.5	R=100	40°		144107
	15.0	15.0	2.5	R=150	30°		100791
	14.0	14.0	2.0	R=150	30°		100789
	15.0	15.0	2.5	R=50	30°		101044

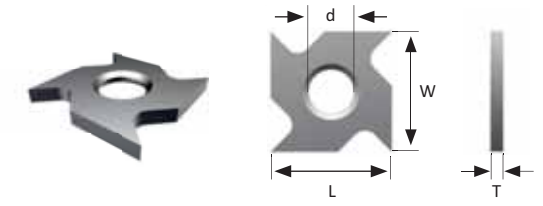







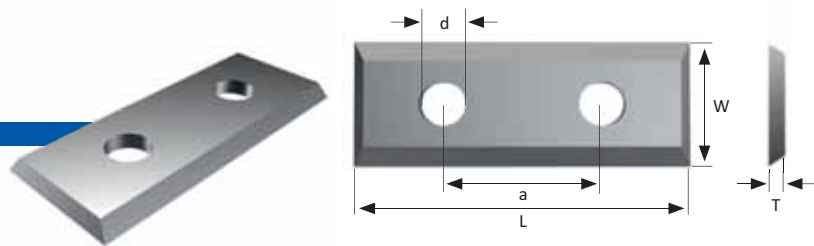



EN Spurs, grooving knives  
 DE Vorschneider, Nuter  
 FR Araseur, couteaux pour rainures  
 IT Rasanti, coltelli per scanalature  
 HU Elővágók, horonyvágók

	L mm	W mm	T mm		d mm	T07MF-CR	T10MG
	18.0	18.0	1.95			013293	
	18.0	18.0	2.45			013291	
	18.0	18.0	2.95			013305	
	18.0	18.0	3.70			013289	
	22.9	19.8	2.5	30°		045180	
	22.0	19.0	2.0	30°		013271	
	14.0	28.0	2.0	30°		013258	
	16.0	16.0	3.0	32°		030829	
	18.5		3.25	30°			017190
	33.5				3.0	013252	
	18.9	7.9	4.0			013253	
	18.0	5.7	3.5			013255	
	24.5	13.0	4.0			053640	
	24.5	13.0	5.0			053641	
	24.5	13.0	6.0			053642	
	34.0	16.0	4.0				013278
	34.0	16.0	5.0				013279
	34.0	16.0	6.0				013280

	d1 mm	d2 mm	d3 mm	T mm	T03SMG
	11.0	7.0	5.1	4.0	013373



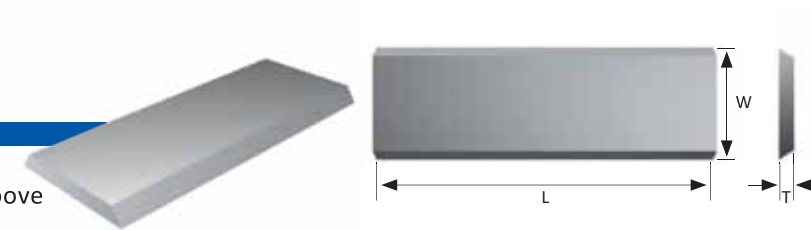

EN 4 cutting edges / special knives  
 DE 4 Schneidkanten / Sondermesser  
 FR 4 tranchants / couteaux spéciaux  
 IT 4 taglienti / coltelli speciali  
 HU 4 vágóélű / speciális kések

	L mm	W mm	T mm	a mm	T04F-CR	T02SMG	T03SMG	T10MG
	19.5	7.0	1.5		013492			
	19.5	8.0	1.5		013494			
	19.5	9.0	1.5		013495			
	19.5	10.0	1.5		013496			
	19.5	12.0	1.5		013498		013947	
	29.5	7.0	1.5	14.0	013501			
	29.5	7.5	1.5	14.0	013502			
	29.5	8.0	1.5	14.0	013503			
	29.5	9.0	1.5	14.0	013504	054432		
	29.5	10.0	1.5	14.0	013505			
	29.5	11.0	1.5	14.0	013506			
	29.5	12.0	1.5	14.0	013507	047361	013952	014088
	39.5	9.0	1.5	26.0	013511	121138	045134	
	39.5	12.0	1.5	26.0	013512	128797	013954	
	49.5	8.0	1.5	26.0	013516			
	49.5	9.0	1.5	26.0	013517	109052	013956	
	49.5	10.0	1.5	26.0	013518			
	49.5	12.0	1.5	26.0	013520	049019	013957	014090
	59.5	12.0	1.5	26.0	013523			
	50.0	9.0	1.5	37.0	016950		035425	
	50.0	12.0	1.7	37.0	013327	054444	013866	014030
	16.0	7.0	1.5	7.0	016934		016933	
	23.0	7.0	1.5	14.0	053449			
	28.0	7.0	1.5	14.0	016823	102847	016822	
	16.0	7.0	1.5	7.0	048995			
	16.0	7.0	1.5	7.0	048996			
	23.0	7.0	1.5	14.0	106866			
	23.0	7.0	1.5	14.0	106867			
	31.5	9.0	1.5	14.0	109149			



EN Face groove, back groove and crossgroove  
 DE Brust-, Rücken- und Quernut  
 FR Rainure sur grande face, sur petite face et transversal  
 IT Scanalatura frontale, posteriore e di sicurezza  
 HU Homlok-, hát- és keresztbarázdás kések

	L mm	W mm	T mm	T04F-CR	T03SMG	Style
	50.0	5.5	1.1	013361		EN Back groove DE Rückennut FR Rainure sur petite face IT Scanalatura posteriore HU Hátbarázdás
	20.0	4.1	1.1	013403		EN Back and crossgroove DE Rücken- und Quernut FR Rainure transversale IT Scanalatura di sicurezza HU Hát- és keresztbarázdás
	20.0	5.5	1.1	013394	013920	
	25.0	5.5	1.1	013402		
	30.0	5.5	1.1	013397	013914	
	50.0	5.5	1.1	013401	013918	
	20.0	5.5	1.1	013378		EN 4 Cutting edges DE 4 Schneidkanten FR 4 Tranchants IT 4 Taglienti HU 4 vágóélű
	25.0	5.5	1.1	013376		
	30.0	5.5	1.1	013379		
	35.0	5.5	1.1	013377		
	40.0	5.5	1.1	013380		
	44.5	5.5	1.1	013375		
	50.0	5.5	1.1	013381		



EN Systems Leitz, Oertli  
 DE Systeme Leitz, Oertli  
 FR Systèmes Leitz, Oertli  
 IT Sistemi Leitz, Oertli  
 HU Rendszer Leitz, Oertli

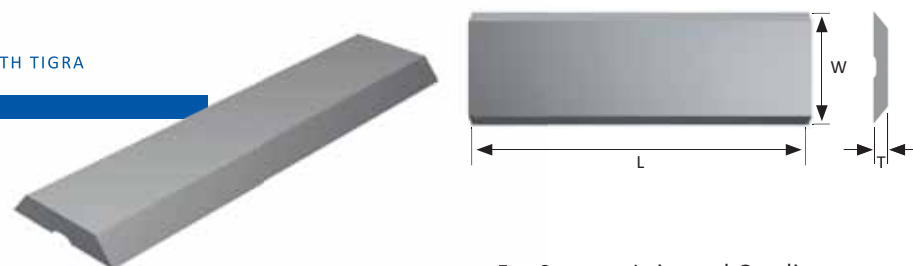

For Systems Leitz and Oertli

Leitz rendszer*	L mm	W mm	T mm	T04F-CR Microfinish	T12SMG Microfinish
	7.7	8.0	1.5	142707	142648
	9.7	8.0	1.5	142708	142649
	11.7	8.0	1.5	142709	142650
	14.7	8.0	1.5	129343	142651
	19.7	8.0	1.5	142710	142653
	24.7	8.0	1.5	142711	142654
	30.0	8.0	1.5	142712	142656
	35.0	8.0	1.5	142713	142657
	40.0	8.0	1.5	142714	142658
	45.0	8.0	1.5	142715	142659
	50.0	8.0	1.5	142716	142660
	60.0	8.0	1.5	142717	142661
	70.0	8.0	1.5	142718	142662
	80.0	8.0	1.5	038329	142663
	100.0	8.0	1.5	142719	142664
	120.0	8.0	1.5	142720	142665
	150.0	8.0	1.5	137028	140017
	160.0	8.0	1.5	134774	141256
	180.0	8.0	1.5	137029	140303
	240.0	8.0	1.5	137030	140304
	260.0	8.0	1.5	134775	141257

Oertli rendszer	L mm	W mm	T mm	T04F-CR
	9.5	8.0	1.5	030933
	12.0	8.0	1.5	030935
	15.0	8.0	1.5	030936
	20.0	8.0	1.5	030937
	25.0	8.0	1.5	030938
	32.0	8.0	1.5	030940
	40.0	8.0	1.5	030941
	50.0	8.0	1.5	030942
	60.0	8.0	1.5	030943
	80.0	8.0	1.5	030944
	100.0	8.0	1.5	030945
	12.0	12.0	1.5	034294

EN For use in Leitz/Oertli-cutterheads only  
 DE Nur zur Verwendung in Messerköpfen der Firma Leitz bzw. Oertli  
 FR Utilisation limitée aux porte outils des entreprises Leitz et Oertli  
 IT Da usare solo su teste portacoltelli della Leitz - Oertli  
 HU Csak Leitz, ill. Oertli gyártmányú késfejekhez használható

EN System KWO/Versofix  
 DE System KWO/Versofix  
 FR Système KWO/Versofix  
 IT Sistema KWO/Versofix  
 HU KWO/Versofix rendszer

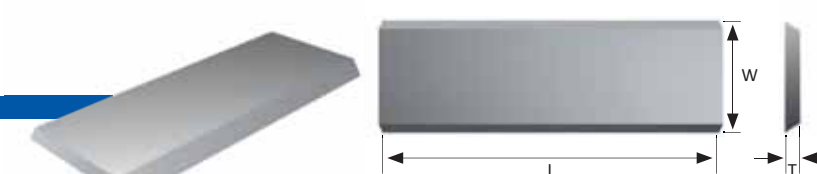

For SystemKWO/Versofix

KWO/Versofix rendszerhez*	L mm	W mm	T mm	T03SMG TiN-bevonatos	T10MG TiN-bevonatos
	20.0	5.5	1.1	049525	049526
	20.0	10.0	1.5	014273	030841
	30.0	10.0	1.5	014275	030842
	50.0	10.0	1.5	014277	030843

EN Reversible knives with chip breakers  
 DE Wendeschneidplatten mit Spanbrechernuten  
 FR Plaquettes réversibles avec brise copeaux  
 IT Coltellini con rompitruciolo  
 HU Váltólapkák forgácstörővel

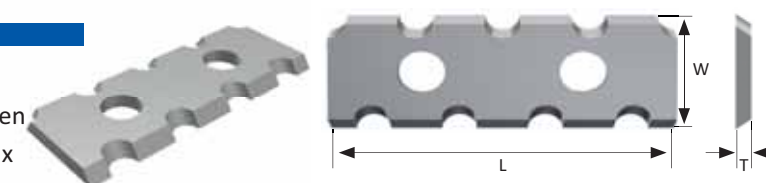



L mm	W mm	T mm	a mm	T04F-CR
30.0	12.0	1.5	14.0	013117
50.0	12.0	1.5	26.0	013127
60.0	12.0	1.5	26.0	108318

EN For use in KWO/Versofix-cutterheads only  
 DE Nur zur Verwendung in Messerköpfen der Firma KWO/Versofix  
 FR Utilisation limitée aux porte outils de l'entreprise KWO/Versofix  
 IT Da usare solo su teste portacoltelli della KWO/Versofix  
 HU Csak KWO/Versofix gyártmányú késfejekhez használható

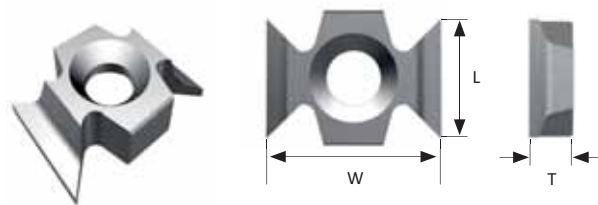
EN Edge rounding knives  
 DE Kantenrunder  
 FR Couteaux brise-arrête  
 IT Spigolatori  
 HU Éllekerekítő kések



	L mm	W mm	T mm	Type	T10MG
	16.0	22.0	5.0	TKM 45°	032292
	16.0	22.0	5.0	TKM R 1.5	032294
	16.0	22.0	5.0	TKM R 2.0	032295
	16.0	22.0	5.0	TKM R 2.5	032296
	16.0	22.0	5.0	TKM R 3.0	032297
	16.0	22.0	5.0	TKM R 4.0	032299
	16.0	22.0	6.0	TKM R 5.0	032301
 A "Mechanical" Leitz rendszerhez *	15.0	20.0	8.0	TKM 11/0 - 45°	032304
	15.0	22.3	9.0	TKM 12/0 R3	032306
	15.0	20.0	7.3	TKM 12/3 R2	032308
	15.0	20.0	7.0	TKM 12/4 R1.5	032310
 A "BG-Test" Leitz rendszerhez *	15.0	23.0	8.0	TKM 21/0 - 45°	032316
	15.0	23.0	9.0	TKM 22/0 R3	032318
	15.0	25.7	7.3	TKM 24/0 R5	032327
	15.0	25.7	7.3	TKM 24/1 R5	032326

EN For use in Leitz-cutterheads only  
 DE Nur zur Verwendung in Messerköpfen der Firma Leitz  
 FR Utilisation limitée aux porte outils de l'entreprise Leitz  
 IT Da usare solo su teste portacoltelli della Leitz  
 HU Csak Leitz gyártmányú késfejekhez használható

EN PCD Reversible Knives  
 DE PKD-Wendeschneidplatten  
 FR Plaquettes réversibles PCD  
 IT Coltelli reversibili PCD  
 HU DIA (PCD) váltólapkák

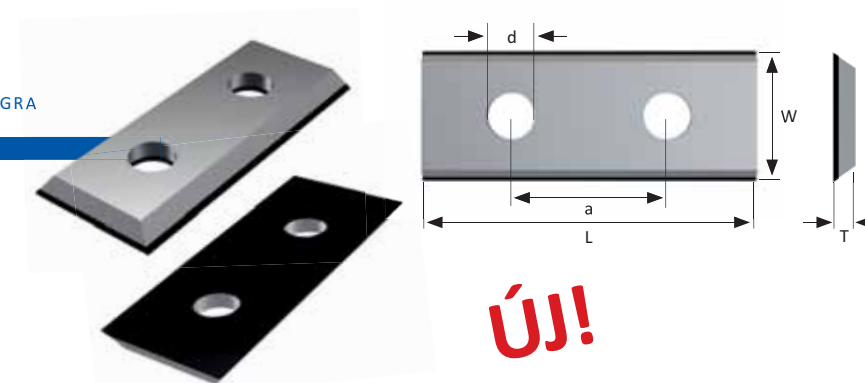











	L mm	W mm	T mm	a mm	d mm	MS-W
	12	12	1.5		4.1	156292
	20	12	1.5		4.1	158514
	30	12	1.5	14	4.1	155195
	50	12	1.5	26	4.1	155192
4 vágóélű 	29.5	12	1.5	14	4.1	161192
	49.5	12	1.5	26	4.1	161191



- EN Blanks for profiling and radius knives
- DE Blanketts zum Profilieren und Radienplatten
- FR Plaquettes à profiler et plaquettes profilées
- IT Placchette da profilare e placchette profilate
- HU Profilozható nyerslapkák és rádiuszos kések



EN Blanks for profiling and radius knives  
 DE Blanketts zum Profilieren und Radienplatten  
 FR Plaquettes à profiler et plaquettes profilées  
 IT Placchette da profilare e placchette profilate  
 HU Profilozható nyerslapkák és rádiuszos kések

	EN With 1 bore hole at the bottom DE Mit 1 Bohrung unten FR Avec 1 trou en bas IT Con 1 foro basso HU 1 alsó furattal	44 - 46
	EN With 2 bore holes at the bottom DE Mit 2 Bohrungen unten FR Avec 2 trous en bas IT Con 2 fori bassi HU 2 alsó furattal	47 - 51
	EN With 1 bore hole in the center DE Mit 1 Bohrung mittig FR Avec 1 trou au centre IT Con 1 foro centrale HU 1 középponti furattal	52
	EN With 2 bore holes in the center DE Mit 2 Bohrungen mittig FR Avec 2 trous au centre IT Con 2 fori centrali HU 2 középső furattal	52
	EN Special blanks for profiling DE Spezial-Blanketts zum Profilieren FR Plaquettes spéciales à profiler IT Placchette speciali da profilare HU Profilozható speciális nyerslapkák	53
	EN Superprofiler & backing plates DE Superprofiler & Stützplatten FR Superprofiler & supports IT Superprofiler & supporti HU Superprofiler & lapkatámaszok	54
	EN Systems Freud / Leuco / Oertli DE Systeme Freud / Leuco / Oertli FR Systèmes Freud / Leuco / Oertli IT Sistemi Freud / Leuco / Oertli HU Freud / Leuco / Oertli rendszerekhez	55 - 57
	EN System Proficut DE System Proficut FR Système Proficut IT Sistema Proficut HU Proficut rendszerü	58 - 59
	EN Without bores DE Ohne Bohrung FR Sans trous IT Senza fori HU Furat nélküli	59 - 60
	EN Profiled & preprofiled standard blanks DE Profilierte und vorprofilierte Standardblanketts FR Plaquettes standard profilées & préprofilées IT Placchette profilate & presagomate standard HU Profilos & előprofilozott standard lapkák	61 - 64
	EN Packing boxes DE Verpackungsschachteln FR Caissons d'emballage IT Contenitori per imballo HU Csomagoló doboz	65

EN Blanks for profiling and radius knives - Carbide grades and their applications  
 DE Blanketts zum Profilieren und Radienplatten - Hartmetallsorten und ihre Anwendungen  
 FR Plaquettes à profiler et plaquettes profilées - Les nuances de carbures et leurs applications  
 IT Placchette da profilare e placchette profilate - I tipi di metallo duro e le loro applicazioni  
 HU Profilozható nyerslapkák és rádiuszos kések - Vídia kategóriák és felhasználásuk

EN DE FR IT HU	TIGRA grade TIGRA - Sorte Nuance TIGRA Tipo TIGRA TIGRA kategória	ISO ISO ISO ISO ISO	USA USA USA Stati Uniti EE.UU.	Hardness Härte Dureté Durezza Keménység	Toughness Zähigkeit Ténacité Tenacità Szívósság	Bending strength Biegebruchfestigkeit Résistance à la flexion Resistenza flessionale Hajlítószilárdság	Plastics Plastik Plastiques Plastica Műanyag	HDF HDF HDF HDF HDF	MDF MDF MDF MDF MDF	Chipboard Spanplatte Panneaux de particule Truciolare Forgácslap	Hardwood Hartholz Bois dur Legno duro Keményfa	Softwood Weichholz Bois tendre Legno tenero Puhafa	Main usage Hauptverwendung Usage principal Usò principale Fő felhasználási terület
	T03SMG	K01	C4++	↑	↖	→	✓	✓	✓	✓	○	▣	EN Man-made materials DE Künstlich hergestellte Materialien FR Matériaux synthétiques IT Materiali artificiali HU Szintetikus anyagok
	T04MG-CR	K01	C4+	→	→	→	✓	○	✓	✓	✓	▣	EN Tropical, abrasive hard woods; chipboard DE Tropische, abrasive Harthölzer; Spanplatte FR Tropical, abrasif bois durs; panneaux IT Legni duri tropicali, abrasivi; truciolare HU Trópusi, koptató, keményfák, forgácslap
	T04F-CR UNIVERSAL	K05	C4	→	↖	→	✓	○	✓	✓	✓	✓	EN Universal use DE Universeller Einsatz FR Usage universel IT Uso universale HU Univerzálisan felhasználható
	T10MG	K10 - K40	C3+	↖	↖	↖	○	▣	▣	▣	✓	✓	EN Natural wood, window tooling DE Naturholz, Fensterwerkzeuge FR Bois naturel, outillage de fenêtré IT Legni naturali, utensili per finestre HU Természetes fa, ablakgyártó szerszámok
	TL15*	K10 - K40	C3+	↖	↑	↑	▣	▣	▣	▣	✓	✓	EN Wood with knots, high clearance angles DE Holz mit Ästen, große Freiwinkel FR Bois avec des noeuds, grands angles de dépouille IT Legni nodosi, ampi angoli di spoglia HU Csomós fák, nagy hézagszögekkel
	TL20*	K10 - K40	C3+	↓	↑	↑	▣	▣	▣	▣	✓	✓	EN Northern European soft woods DE Nordeuropäische Weichhölzer FR Bois tendre d'Europe du Nord IT Legni teneri del Nord Europa HU Észak-európai puhafák

✓ kiváló teljesítőképesség  
 ✓ nagyon jó teljesítményű  
 ○ elfogadható  
 ▣ nem alkalmas

CR = Co + Ni + Cr = corrosion resistant - korrosionsbeständig - anti-corrosif - inossidabile - korrózióálló

\* Special binder - Spezialbinder - Liant spécial - Legante speciale - Speciális kötőanyag

EN For technical data, please refer to the pages 4-5.  
 DE Die technischen Daten entnehmen Sie bitte den Seiten 4-5.  
 FR Pour les données techniques, veuillez voir aux pages 4-5.

IT Per i dati tecnici, fare riferimento alle pagine 4-5.  
 HU A műszaki adatokat a 4-5. oldalon találja.



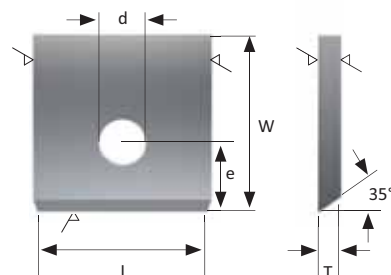
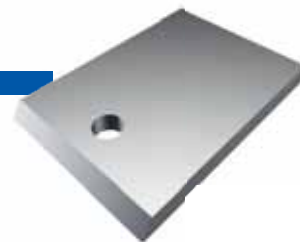

EN Blanks for profiling  
 DE Blanketts zum Profilieren  
 FR Plaquettes à profiler  
 IT Placchette da profilare  
 HU Profilozható nyerslapkák

L mm	W mm	T mm	d mm	e mm	T04F-CR	T10MG
15.0	15.4	2.0	4.1	6.3	014535	030950
15.0	20.4	2.0	4.1	6.3	014553	014559
15.0	25.4	2.0	4.1	6.3	014573	014577
15.0	30.4	2.0	4.1	6.3	014590	014595
16.0	20.4	2.0	4.1	6.3	014609	030955
20.0	20.4	2.0	4.1	6.3	014648	014655
20.0	25.4	2.0	4.1	6.3	014684	014692
20.0	30.4	2.0	4.1	6.3	014723	014729
20.0	35.4	2.0	4.1	6.3	014750	014756
20.0	40.4	2.0	4.1	6.3	014768	030960
25.0	20.4	2.0	4.1	6.3	014783	014789
25.0	25.4	2.0	4.1	6.3	014812	014819
25.0	30.4	2.0	4.1	6.3	014848	014856
25.0	35.4	2.0	4.1	6.3	014880	014887
30.0	20.4	2.0	4.1	6.3	014917	014922
30.0	25.4	2.0	4.1	6.3	014970	014980
30.0	30.4	2.0	4.1	6.3	015045	015054
30.0	35.4	2.0	4.1	6.3	015104	015113
30.0	40.4	2.0	4.1	6.3	015148	015154
35.0	20.4	2.0	4.1	6.3	015261	015265
35.0	25.4	2.0	4.1	6.3	015286	015290
35.0	30.4	2.0	4.1	6.3	015334	015339
35.0	35.4	2.0	4.1	6.3	015368	015372
35.0	40.4	2.0	4.1	6.3	015398	015403

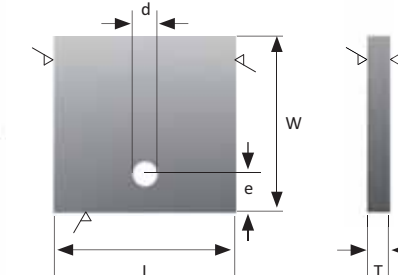

EN Blanks for profiling  
 DE Blanketts zum Profilieren  
 FR Plaquettes à profiler  
 IT Placchette da profilare  
 HU Profilozható nyerslapkák

L mm	W mm	T mm	d mm	e mm	T04F-CR	T10MG
15.0	15.4	2.0	4.1	6.5	014536	014540
15.0	20.4	2.0	4.1	6.5	014554	014560
15.0	25.4	2.0	4.1	6.5	014574	014578
15.0	30.4	2.0	4.1	6.5	014591	014596
16.0	20.4	2.0	4.1	6.5	014610	030989
20.0	20.4	2.0	4.1	6.5	014649	014656
20.0	25.4	2.0	4.1	6.5	014686	014694
20.0	25.3	2.0	4.1	6.0	018851	030995
20.0	30.4	2.0	4.1	6.5	014725	014731
20.0	35.4	2.0	4.1	6.5	014751	014757
20.0	40.4	2.0	4.1	6.5	031018	031020
24.0	28.3	2.0	4.1	6.0	018852	031001
25.0	25.4	2.0	4.1	6.5	014813	014820
25.0	30.4	2.0	4.1	6.5	014849	014858
25.0	35.4	2.0	4.1	6.5	014881	014888
30.0	20.4	2.0	4.1	6.5	014918	014923
30.0	25.4	2.0	4.1	6.5	014972	014982
30.0	30.4	2.0	4.1	6.5	015047	015056
30.0	30.4	2.0	6.0	6.5	019385	
30.0	35.4	2.0	4.1	6.5	015106	015114
30.0	40.4	2.0	4.1	6.5	015149	015155
35.0	20.4	2.0	4.1	6.5	015262	015266
35.0	25.4	2.0	4.1	6.5	015287	015291
35.0	30.4	2.0	4.1	6.5	015335	015340
35.0	35.4	2.0	4.1	6.5	015369	015373
40.0	30.3	2.0	4.1	6.0	018856	031016

EN Blanks for profiling  
 DE Blanketts zum Profilieren  
 FR Plaquettes à profiler  
 IT Placchette da profilare  
 HU Profilozható nyerslapkák

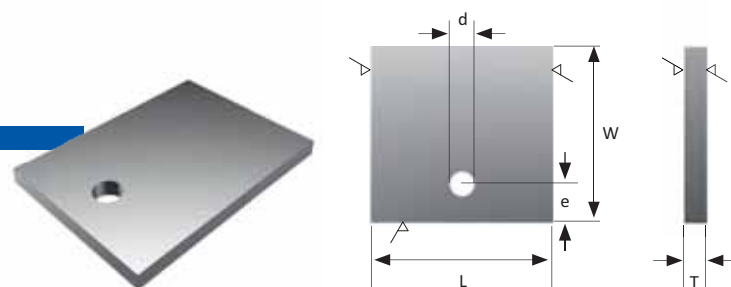

**Italian Style**

	L mm	W mm	T mm	d mm	e mm	T04F-CR	T10MG
	15.0	20.4	2.0	4.5	6.5	034989	014569
	15.0	25.4	2.0	4.5	6.5	034971	014585
	15.0	30.4	2.0	4.5	6.5	034972	014606
	20.0	20.4	2.0	4.5	6.5	034973	014665
	20.0	25.4	2.0	4.5	6.5	034974	014708
	20.0	30.4	2.0	4.5	6.5	034975	014741
	20.0	35.4	2.0	4.5	6.5	034976	014764
	25.0	20.4	2.0	4.5	6.5	034977	014799
	25.0	25.4	2.0	4.5	6.5	034978	014834
	25.0	30.4	2.0	4.5	6.5	034979	014871
	25.0	35.4	2.0	4.5	6.5	034980	014895
	30.0	20.4	2.0	4.5	6.5	034981	014935
30.0	25.4	2.0	4.5	6.5	034982	014995	
30.0	30.4	2.0	4.5	6.5	034983	015068	
35.0	25.4	2.0	4.5	6.5	034986	015301	

	L mm	W mm	T mm	d mm	e mm	T04F-CR	T10MG
	15.0	20.4	2.0	4.5	6.5	034970	014570
	15.0	25.4	2.0	4.5	6.5	034990	031046
	15.0	30.4	2.0	4.5	6.5	034991	014607
	20.0	20.4	2.0	4.5	6.5	034992	014666
	20.0	25.4	2.0	4.5	6.5	034993	014709
	20.0	30.4	2.0	4.5	6.5	034994	014742
	20.0	35.4	2.0	4.5	6.5	034995	014765
	25.0	20.4	2.0	4.5	6.5	041075	014800
	25.0	25.4	2.0	4.5	6.5	034996	014835
	25.0	30.4	2.0	4.5	6.5	034997	014872
	25.0	35.4	2.0	4.5	6.5	038344	014896
	30.0	20.4	2.0	4.5	6.5	034998	031066
	30.0	25.4	2.0	4.5	6.5	038900	014996
	30.0	30.4	2.0	4.5	6.5	015066	015069
	30.0	35.4	2.0	4.5	6.5	042107	100456
	30.0	40.4	2.0	4.5	6.5	042108	015163

EN Blanks for profiling  
 DE Blanketts zum Profilieren  
 FR Plaquettes à profiler  
 IT Placchette da profilare  
 HU Profilozható nyerslapkák

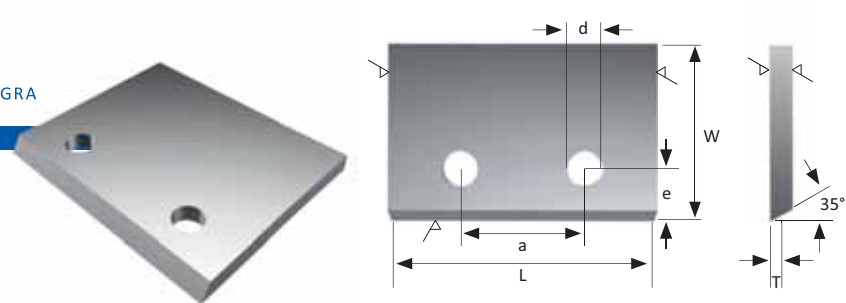

L mm	W mm	T mm	d mm	a mm	e mm	T04F-CR	T10MG
30.0	20.4	2.0	4.1	14.0	6.0	017771	031073
30.0	20.4	2.0	4.1	14.0	5.5	014937	014940
30.0	20.4	2.0	4.1	14.0	6.3	039328	041233
30.0	25.4	2.0	4.1	14.0	5.5	014999	012957
30.0	25.4	2.0	4.1	14.0	6.3	015007	031075
30.0	30.4	2.0	4.1	14.0	5.5	015072	031077
30.0	30.4	2.0	4.1	14.0	6.3	039329	041236
30.0	35.4	2.0	4.1	14.0	5.5	015125	031080
30.0	35.4	2.0	4.1	14.0	6.3	019495	041239
30.0	40.4	2.0	4.1	20.0	5.5	015164	031082
31.8	25.4	2.0	4.1	16.0	6.3	041067	036909
35.0	20.4	2.0	4.1	14.0	5.5	031085	031086
35.0	25.4	2.0	4.1	14.0	6.3	039575	041242
35.0	25.4	2.0	4.1	18.0	6.3	019885	041336
35.0	30.4	2.0	4.1	20.0	5.5	015356	031095
35.0	30.4	2.0	4.1	14.0	6.3	039576	041245
35.0	35.4	2.0	4.1	14.0	6.3	039577	041248
35.0	40.4	2.0	4.1	20.0	5.5	015410	031097
35.0	40.4	2.0	4.1	14.0	6.3	039578	041251
40.0	20.4	2.0	4.1	26.0	5.5	015440	015447
40.0	20.4	2.0	4.1	26.0	6.3	039566	041254
40.0	25.4	2.0	4.1	20.0	5.5	015502	031099
40.0	25.4	2.0	4.1	26.0	5.5	015482	015492
40.0	25.4	2.0	4.1	26.0	6.0	017623	031102
40.0	25.4	2.0	4.1	26.0	6.3	039330	041256
50.0	20.4	2.0	4.1	26.0	6.3	039392	041265
50.0	25.4	2.0	4.1	26.0	5.5	015841	015849
50.0	25.4	2.0	4.1	26.0	6.3	039568	041267



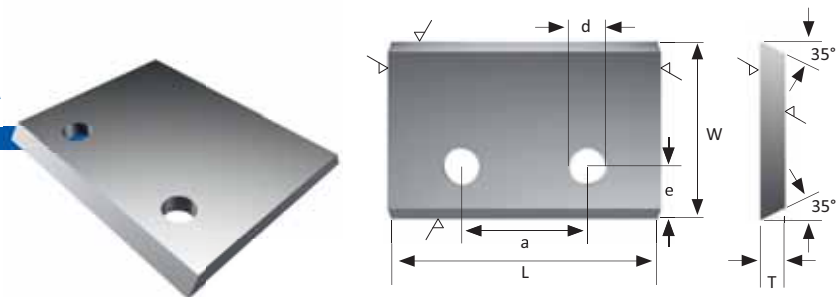

EN Blanks for profiling  
 DE Blanketts zum Profilieren  
 FR Plaquettes à profiler  
 IT Placchette da profilare  
 HU Profilozható nyerslapkák

L mm	W mm	T mm	d mm	a mm	e mm	T04F-CR	T10MG
40.0	30.0	2.0	4.1	20.0	5.5	015542	015548
40.0	30.0	2.0	4.1	26.0	5.5	015560	015566
40.0	30.0	2.0	4.1	26.0	6.3	015571	041259
40.0	35.0	2.0	4.1	26.0	5.5	015611	015620
40.0	35.0	2.0	4.1	26.0	6.0	015629	031105
40.0	35.0	2.0	4.1	20.0	5.5	015630	031108
40.0	35.0	2.0	4.1	26.0	6.3	039331	041261
40.0	40.0	2.0	4.1	26.0	6.0	015646	015649
40.0	40.0	2.0	4.1	20.0	6.0	015655	015659
40.0	40.0	2.0	4.1	26.0	6.3	039567	041264
40.0	45.0	2.0	4.1	26.0	6.0	019372	041334
50.0	16.0	2.0	4.1	26.0	5.5	017639	031112
50.0	20.0	2.0	4.1	26.0	5.5	015804	031117
50.0	30.0	2.0	4.1	26.0	5.5	015871	015878
50.0	30.0	2.0	4.1	26.0	6.3	039569	015884
50.0	35.0	2.0	4.1	26.0	5.5	015905	031124
50.0	35.0	2.0	4.1	26.0	6.3	018387	041269
50.0	40.0	2.0	4.1	26.0	6.3	019030	041272
50.0	45.0	2.0	4.1	34.0	6.0	015940	031129
60.0	20.0	2.0	4.1	26.0	5.5	016001	031135
60.0	25.0	2.0	4.1	26.0	5.5	016031	016037
60.0	30.0	2.0	4.1	26.0	6.0	016068	031144
60.0	30.0	2.0	4.1	26.0	6.3	039571	016082
60.0	30.0	2.0	4.1	44.0	6.0	016076	031146
60.0	35.0	2.0	4.1	44.0	6.0	016126	031149
60.0	40.0	2.0	4.1	26.0	6.3	039573	041280
60.0	40.0	2.0	4.1	44.0	6.0	016158	016170
60.0	45.0	2.0	4.1	44.0	6.0	019375	031151
80.0	30.0	2.0	4.1	60.0	6.3	039580	041284
80.0	35.0	2.0	4.1	60.0	6.3	041286	041288
80.0	40.0	2.0	4.1	60.0	6.3	041292	041294
80.0	45.0	2.5	4.1	60.0	6.0	016321	016323
100.0	45.0	2.5	4.2	80.0	6.0	014519	031160

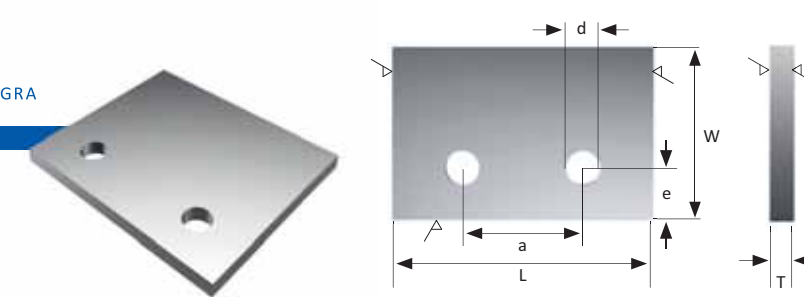

EN Blanks for profiling  
 DE Blanketts zum Profilieren  
 FR Plaquettes à profiler  
 IT Placchette da profilare  
 HU Profilozható nyerslapkák

L mm	W mm	T mm	d mm	a mm	e mm	T04F-CR	T10MG
19.0	30.0	2.0	3.6	8.0	4.75	017790	031964
25.4	30.6	2.0	3.6	14.3	4.75	017791	031967
30.0	20.4	2.0	4.1	14.0	6.5	014938	014941
30.0	25.4	2.0	4.1	14.0	6.5	015000	015003
30.0	25.4	2.0	4.1	19.0	4.75	017603	031970
30.0	30.4	2.0	4.1	14.0	6.5	015073	015077
30.0	30.2	2.0	4.1	19.0	4.75	017605	031975
30.0	35.4	2.0	5.5	12.0	6.0	033964	041328
30.0	35.4	2.0	4.1	14.0	6.5	015126	015129
30.0	40.4	2.0	4.1	14.0	6.5	015165	031979
35.0	20.4	2.0	4.1	14.0	6.5	015275	031989
35.0	25.4	2.0	4.1	14.0	6.5	015306	015312
35.0	30.4	2.0	4.1	14.0	6.5	015351	015354
35.0	35.4	2.0	4.1	14.0	6.5	015383	015385
35.0	40.4	2.0	4.1	14.0	6.5	015411	015414
40.0	20.4	2.0	5.5	26.0	5.5	037885	041339
40.0	20.4	2.0	4.1	26.0	6.5	015441	015448
40.0	25.4	2.0	4.1	26.0	6.5	015484	015493
40.0	30.2	2.0	5.0	27.0	6.3	035290	041299
40.0	30.4	2.0	4.1	26.0	6.5	015544	015550
40.0	30.4	2.0	6.0	26.0	5.5	019253	
40.0	35.4	2.0	5.0	27.0	6.3	018955	041301
40.0	35.4	2.0	4.1	26.0	6.5	015612	015622
40.0	35.4	2.0	6.0	26.0	5.5	019471	
40.0	40.2	2.0	5.0	27.0	6.3	019002	041304
40.0	40.4	2.0	4.1	26.0	6.5	015647	015650
40.0	45.4	2.0	4.1	26.0	6.5	015676	015677

EN Blanks for profiling  
 DE Blanketts zum Profilieren  
 FR Plaquettes à profiler  
 IT Placchette da profilare  
 HU Profilozható nyerslapkák

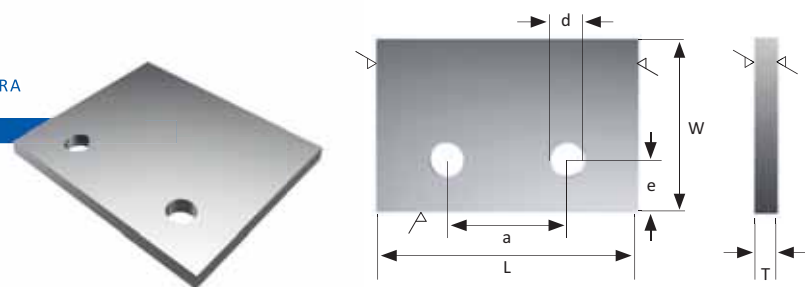

L mm	W mm	T mm	d mm	a mm	e mm	T04F-CR	T10MG
50.0	20.4	2.0	4.1	26.0	6.5	015805	015813
50.0	25.2	2.0	5.0	26.0	6.5	019065	041307
50.0	25.4	2.0	4.1	26.0	6.5	015843	015850
50.0	30.4	2.0	4.1	26.0	6.5	015872	015879
50.0	30.4	2.0	6.0	26.0	6.5	019382	
50.0	35.4	2.0	4.1	26.0	6.5	015897	015902
50.0	40.4	2.0	4.1	26.0	6.5	015917	015920
50.0	40.4	2.0	6.0	26.0	6.5	019383	
50.0	45.4	2.0	4.1	26.0	6.5	015941	032005
50.0	50.4	2.0	4.1	26.0	6.5	015954	015956
60.0	20.4	2.0	4.1	26.0	6.5	016002	016007
60.0	25.4	2.0	4.1	26.0	6.5	016033	016038
60.0	30.4	2.0	4.1	26.0	6.5	016069	016072
60.0	35.4	2.0	4.1	26.0	6.5	016116	016121
60.0	40.4	2.0	4.1	26.0	6.5	016160	016172
80.0	25.4	2.0	4.5	60.0	6.5	035291	041310
80.0	30.4	2.0	4.1	26.0	6.5	016276	016279
80.0	35.4	2.0	4.1	26.0	6.5	016290	016292

EN Blanks for profiling  
 DE Blanketts zum Profilieren  
 FR Plaquettes à profiler  
 IT Placchette da profilare  
 HU Profilozható nyerslapkák

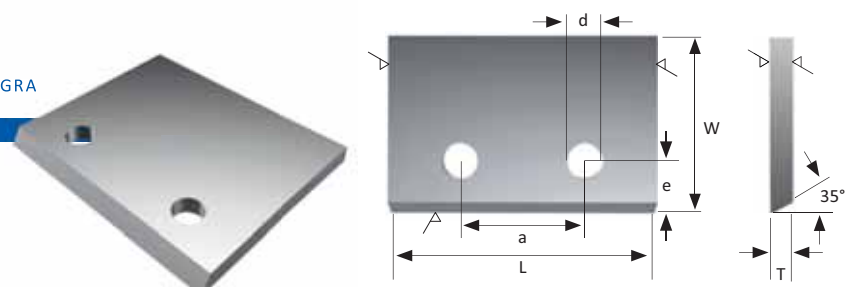

### Italian Style

	L mm	W mm	T mm	d mm	a mm	e mm	T04F-CR	T10MG
	30.0	25.4	2.0	4.5	14.0	6.5	035066	015015
	30.0	30.4	2.0	4.5	14.0	6.5	012981	015088
	30.0	35.4	2.0	4.5	14.0	6.5	035069	015136
	40.0	20.4	2.0	4.5	26.0	6.5	012982	015460
	40.0	25.4	2.0	4.5	26.0	6.5	035073	015508
	40.0	30.4	2.0	4.5	26.0	6.5	035075	015577
	50.0	20.4	2.0	4.5	26.0	6.5	035078	015826
	60.0	20.4	2.0	4.5	26.0	6.5	035084	016012
	60.0	30.4	2.0	4.5	26.0	6.5	016084	016086
	60.0	35.4	2.0	4.5	26.0	6.5	035086	016132

	L mm	W mm	T mm	d mm	a mm	e mm	T04F-CR	T10MG
	30.0	20.4	2.0	4.5	14.0	6.5	014947	050284
	30.0	25.4	2.0	4.5	14.0	6.5	035067	031612
	30.0	30.4	2.0	4.5	14.0	6.5	015085	015086
	30.0	35.4	2.0	4.5	14.0	6.5	035070	031616
	35.0	25.4	2.0	4.5	14.0	6.5	015320	050286
	35.0	30.4	2.0	4.5	14.0	6.5	042115	050287
	35.0	35.4	2.0	4.5	14.0	6.5	015389	050289
	40.0	20.4	2.0	4.5	26.0	6.5	015458	015461
	40.0	25.4	2.0	4.5	26.0	6.5	035074	015509
	40.0	30.4	2.0	4.5	26.0	6.5	035076	015578
	40.0	35.4	2.0	4.5	26.0	6.5	012980	031621
	40.0	40.4	2.0	4.5	26.0	6.5	035077	015667
	50.0	20.4	2.0	4.5	26.0	6.5	035079	015827
	50.0	25.4	2.0	4.5	26.0	6.5	035080	031627
	50.0	30.4	2.0	4.5	26.0	6.5	035081	015889
	50.0	35.4	2.0	4.5	26.0	6.5	042117	050290
	50.0	40.4	2.0	4.5	26.0	6.5	042118	015927
	60.0	20.4	2.0	4.5	26.0	6.5	035085	016013
	60.0	25.4	2.0	4.5	26.0	6.5	041095	036875
	60.0	30.4	2.0	4.5	26.0	6.5	042121	050282
	60.0	35.4	2.0	4.5	26.0	6.5	035087	016133
	60.0	40.4	2.0	4.5	26.0	6.5	042122	050293
	80.0	30.4	2.0	4.5	26.0	6.5	035091	016286
	80.0	35.4	2.0	4.5	26.0	6.5	035092	016300
	80.0	40.4	2.0	4.5	26.0	6.5	042124	100334

EN Blanks for profiling  
 DE Blanketts zum Profilieren  
 FR Plaquettes à profiler  
 IT Placchette da profilare  
 HU Profilozható nyerslapkák

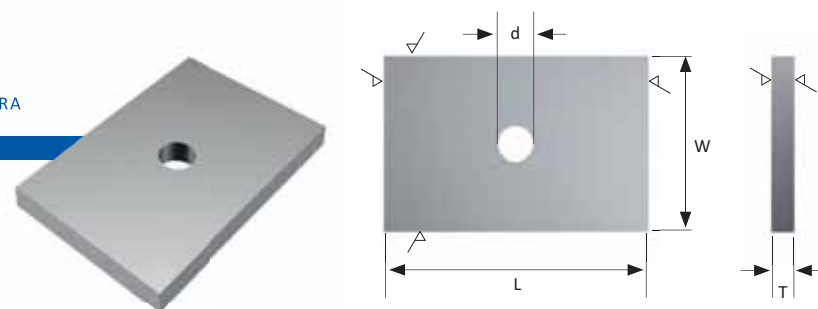

L mm	W mm	T mm	d mm	T04F-CR
20.0	12.0	2.0	4.1	014619
30.0	20.0	2.0	4.1	014914



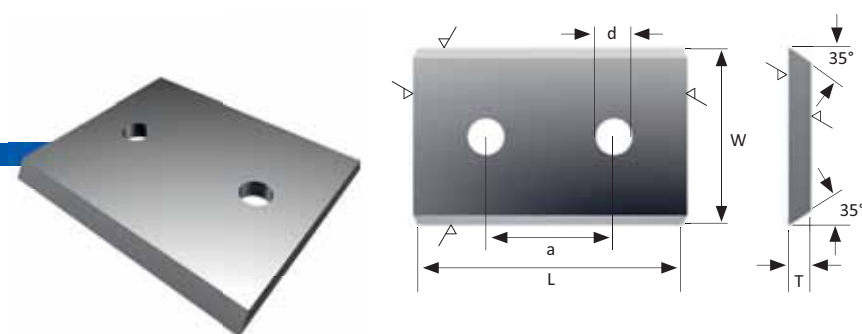

EN Blanks for profiling  
 DE Blanketts zum Profilieren  
 FR Plaquettes à profiler  
 IT Placchette da profilare  
 HU Profilozható nyerslapkák

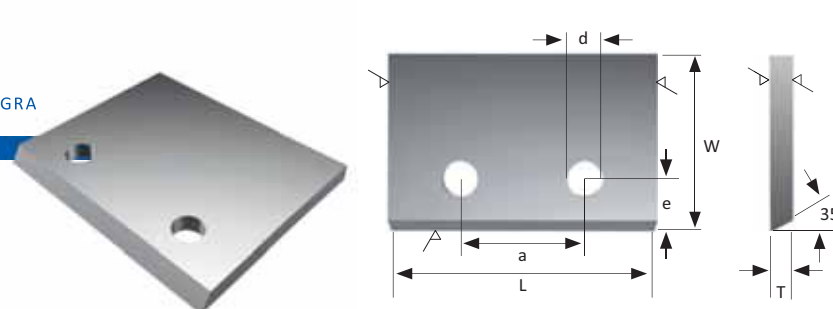

L mm	W mm	T mm	d mm	a mm	T04F-CR	T10MG
30.0	25.0	2.0	3.5	20.0	014956	014962
40.0	30.0	2.0	3.5	20.0	015518	015523
40.0	30.0	2.0	4.1	20.0	015530	031729
40.0	32.62	2.0	3.5	20.0	015583	031735
40.0	35.0	2.0	4.1	20.0	015590	031737
40.0	35.0	2.0	4.1	26.0	015595	015600
40.0	40.0	2.0	4.1	20.0	015641	031742
50.0	25.0	2.0	4.1	26.0	015838	031759
50.0	30.0	2.0	4.1	26.0	015867	031761
50.0	45.0	2.0	4.1	34.0	015931	015935
60.0	24.0	2.0	4.1	36.0	016027	031774
60.0	35.0	2.0	4.1	26.0	016091	031779
60.0	35.0	2.0	4.1	44.0	016098	016104
60.0	42.86	2.0	3.5	20.0	016184	031786

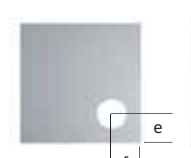
EN Special blanks for profiling  
 DE Spezial-Blanketts zum Profilieren  
 FR Plaquettes spéciales à profiler  
 IT Placchette speciali da profilare  
 HU Speciális profilozható nyerslapkák





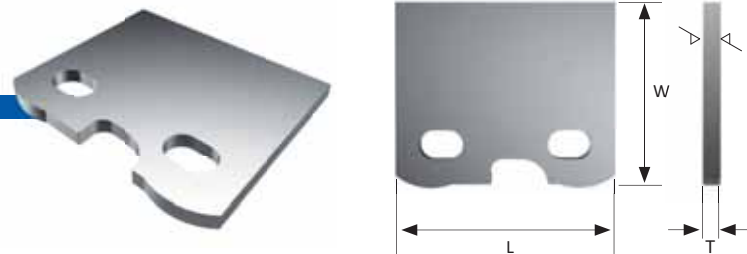

	L mm	W mm	T mm	d mm	a mm	e mm	f mm	T04F-CR
	20.5	20.5	2.0	5.0		5.0	5.0	018084
	25.5	20.5	2.0	5.0		6.0	6.0	018434
	25.5	25.5	2.0	5.0		6.0	6.0	018086
	60.0	30.2	2.0	7.0x4.5	45.5	6.3		035292
	60.0	40.2	2.0	7.0x4.5	45.5	6.3		035293
	60.0	30.4	2.0	5.6	20.0	7.0		019162
	60.0	35.4	2.0	5.6	20.0	7.0		019472
	60.0	40.4	2.0	5.6	20.0	7.0		019163
	80.0	30.4	2.0	5.6	20.0	7.0		019164
	80.0	35.4	2.0	5.6	20.0	7.0		019473
	50.0	25.4	1.5					018343





EN Blanks for profiling  
 DE Blanketts zum Profilieren  
 FR Plaquettes à profiler  
 IT Placchette da profilare  
 HU Profilozható nyerslapkák

Leuco Superprofiler rendszerhez\*

	L mm	W mm	T mm	d mm	e mm	T04F-CR	T04MG-CR	T10MG
	31.0	26.0	1.5			015207	106725	
	41.0	28.0	1.5			015701	102763	015722
	41.0	28.0	2.0			015695		
	41.0	35.0	1.5			015748	106727	015751
	41.0	35.0	2.0			015744		
	51.0	35.0	1.5			015973		
	60.8	30.6	1.5			016209	106731	016225
	60.8	30.6	2.0			016206		
	61.0	45.0	2.0			016234		
	81.0	45.0	2.0			016334		
	40.4	41.2	2.0	4.1	6.0	015756		
	40.4	41.2	2.0	5.1	8.0	033424	106736	033503

EN Backing plates  
 DE Stützplatten  
 FR Supports  
 IT Supporti  
 HU Lapkatámaszok

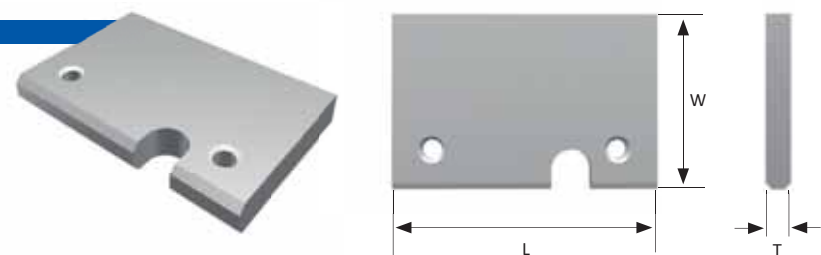



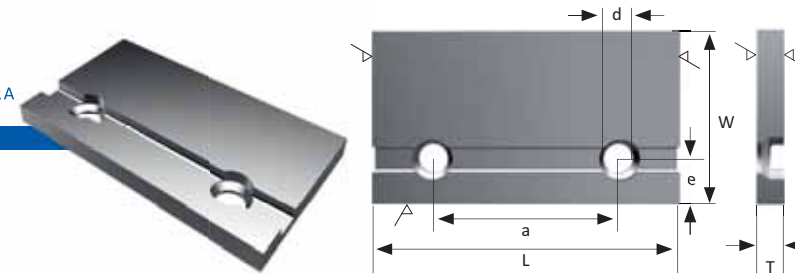

L mm	W mm	T mm	L mm	W mm	T mm	d mm	e mm	Steel
			for Superprofiler					
40.0	26.0	4.0	41.0	28.0	1.5			015705
40.0	33.0	4.0	41.0	35.0	2.0			015749
40.0	38.0	4.0	40.4	41.2	2.0	5.1	8.0	053524
60.0	28.0	4.0	61.0	31.0	1.5			016212
60.0	45.0	6.0	61.0	45.0	2.0			016237
80.0	43.0	6.0	81.0	45.0	2.0			016335

\* EN For use in Leuco-cutterheads only  
 \* DE Nur zur Verwendung in Messerköpfen der Firma Leuco  
 \* FR Utilisation limitée aux porte outils de l'entreprise Leuco  
 \* IT Da usare solo su teste portacoltelli della Leuco  
 \* HU Csak Leuco gyártmányú késfejekhez használható



EN Blanks for profiling  
 DE Blanketts zum Profilieren  
 FR Plaquettes à profiler  
 IT Placchette da profilare  
 HU Profilozható nyerslapkák

Freud rendszerhez\*

	L mm	W mm	T mm	d mm	a mm	e mm	T10MG
	20.0	25.0	3.0	4.5		7.0	031880
	25.0	25.0	3.0	4.5		7.0	031884
	25.0	30.0	3.0	4.5		7.0	031887
	25.0	35.0	3.0	4.5		7.0	031890
	25.0	40.0	3.0	4.5		7.0	031893
	30.0	40.0	3.0	4.5		7.0	031959
	35.0	25.0	3.0	4.5		7.0	031897
	35.0	30.0	3.0	4.5		7.0	031901
	35.0	35.0	3.0	4.5		7.0	031904
		45.0	25.0	3.0	4.5	28.0	7.0
45.0		30.0	3.0	4.5	28.0	7.0	031912
45.0		35.0	3.0	4.5	28.0	7.0	031916
55.0		25.0	3.0	4.5	41.0	6.0	031920
55.0		30.0	3.0	4.5	41.0	6.0	031923
55.0		35.0	3.0	4.5	41.0	6.0	031928
55.0		40.0	3.0	4.5	41.0	6.0	031932
65.0		20.0	3.0	4.5	28.0	6.0	031936
65.0		25.0	3.0	4.5	28.0	6.0	018826
70.0		25.0	3.0	4.5	41.0	6.0	031940
	80.0	30.0	3.0	4.5	66.0	6.0	031944
	80.0	35.0	3.0	4.5	66.0	6.0	031948
	40.0	40.0	3.0	4.5		11/11	031952

\* EN For use in Freud-cutterheads only  
 \* DE Nur zur Verwendung in Messerköpfen der Firma Freud  
 \* FR Utilisation limitée aux porte outils de l'entreprise Freud  
 \* IT Da usare solo su teste portacoltelli della Freud  
 \* HU Csak Freud gyártmányú késfejekhez használható

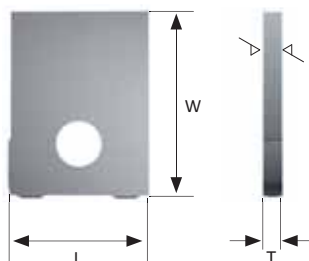
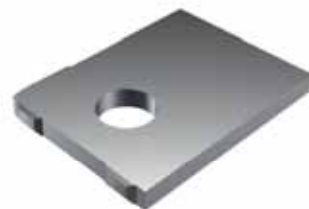

EN Blanks for profiling  
 DE Blanketts zum Profilieren  
 FR Plaquettes à profiler  
 IT Placchette da profilare  
 HU Profilozható nyerslapkák

Leuco 3P-Rendszerhez\*

	L mm	W mm	T mm	T04F-CR
	12.5	20.5	2.0	032346
	15.5	20.5	2.0	032347
	15.5	25.5	2.0	032352
	18.4	25.9	2.0	032356
	22.3	25.5	2.0	032361
	28.2	25.5	2.0	032365

	L mm	W mm	T mm	T04F-CR
	30.2	25.5	2.0	032348
	30.2	30.4	2.0	032367
	32.2	22.8	2.0	032368
	32.2	35.4	2.0	032369
	40.1	30.4	2.0	032373
	45.8	36.0	2.0	032377
	49.9	20.9	2.0	032378
	49.9	33.0	2.0	032379
	49.9	40.2	2.0	032380

\* EN For use in Leuco-cutterheads only  
 \* DE Nur zur Verwendung in Messerköpfen der Firma Leuco  
 \* FR Utilisation limitée aux porte outils de l'entreprise Leuco  
 \* IT Da usare solo su teste portacoltelli della Leuco  
 \* HU Csak Leuco gyártmányú késfejekhez használható

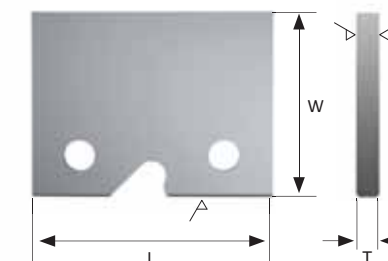
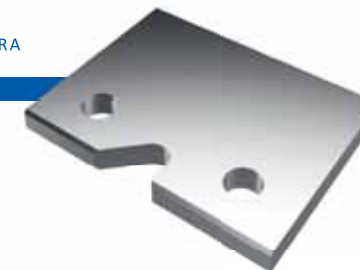

EN Blanks for profiling  
 DE Blanketts zum Profilieren  
 FR Plaquettes à profiler  
 IT Placchette da profilare  
 HU Profilozható nyerslapkák

Also available with Microfinish!  
 Auch mit Microfinish erhältlich!

Oertli rendszerhez\*

	L mm	W mm	T mm	T10MG
	20.0	20.3	2.0	032080
	20.0	24.3	2.0	022565
	20.0	29.3	2.0	022568
	20.0	34.3	2.0	022571
	25.0	19.3	2.0	032086
	25.0	24.3	2.0	022578
	25.0	29.3	2.0	022583
	25.0	34.3	2.0	022559
	30.0	19.3	2.0	032100
	30.0	24.3	2.0	032093
	30.0	29.3	2.0	032095
	30.0	34.3	2.0	022612
	35.0	24.3	2.0	022589
	35.0	29.3	2.0	022594
	35.0	34.3	2.0	032104
	45.0	19.3	2.0	022576
	45.0	24.3	2.0	022597
	45.0	29.3	2.0	022602
	45.0	33.3	2.0	022604
	45.0	34.3	2.0	032111
	55.0	27.8	2.0	032120
	55.0	33.3	2.0	022606
	65.0	22.3	2.0	032126
	65.0	27.8	2.0	032130
	80.0	27.8	2.0	032137
	80.0	33.3	2.0	032140
	25.0	29.3	2.0	0225

\* EN For use in Oertli-cutterheads only  
 \* DE Nur zur Verwendung in Messerköpfen der Firma Oertli  
 \* FR Utilisation limitée aux porte outils de l'entreprise Oertli  
 \* IT Da usare solo su teste portacoltelli della Oertli  
 \* HU Csak Oertli gyártmányú késfejekhez használható

EN Blanks for profiling  
 DE Blanketts zum Profilieren  
 FR Plaquettes à profiler  
 IT Placchette da profilare  
 HU Profilozható nyerslap

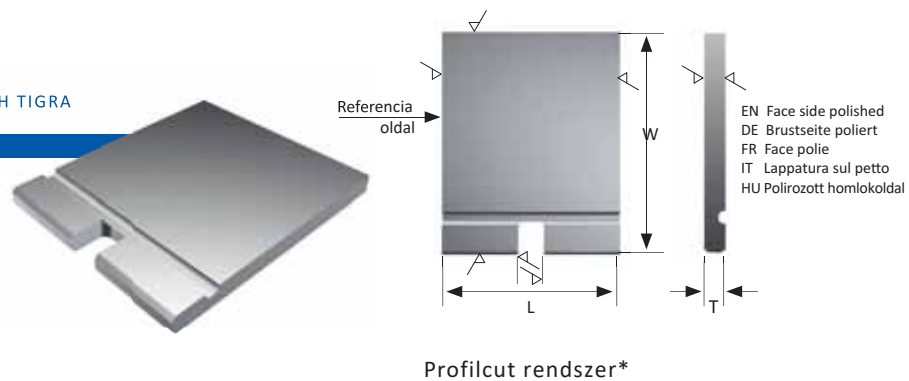

L mm	W mm	T mm	T04F-CR	T10MG
15.2	16.5	2.0	130125	130124
15.2	22.5	2.0	130122	130123
20.2	16.5	2.0	032168	129131
20.2	22.5	2.0	032171	038011
20.2	25.5	2.0	023036	129132
20.2	27.9	2.0	032174	023039
20.2	30.6	2.0	032176	129133
20.2	34.0	2.0	032180	129135
25.2	16.5	2.0	032183	129136
25.2	22.5	2.0	032186	129137
25.2	25.5	2.0	032189	129138
25.2	30.6	2.0	032194	129140
25.2	34.0	2.0	032201	129142
30.2	16.5	2.0	032204	129143
30.2	22.5	2.0	032206	129144
30.2	25.5	2.0	032209	129145
30.2	30.6	2.0	032216	129146
30.2	32.6	2.0	032220	129147
30.2	34.0	2.0	032222	129148
35.2	16.5	2.0	129697	129698
35.2	22.5	2.0	129226	129222
35.2	25.5	2.0	129227	129223
40.2	16.5	2.0	032225	129149
40.2	22.5	2.0	032228	129150
40.2	25.5	2.0	032230	129151
40.2	27.9	2.0	032232	129152
40.2	34.0	2.0	032238	129156
50.2	22.5	2.0	032241	129157
50.2	27.9	2.0	032245	129159
60.2	34.0	2.0	032264	129171
80.2	16.5	2.0	129218	129217
80.2	32.6	2.0	032279	129176

\* EN For use in Leitz-cutterheads only  
 \* DE Nur zur Verwendung in Messerköpfen der Firma Leitz  
 \* FR Utilisation limitée aux porte outils de l'entreprise Leitz  
 \* IT Da usare solo su teste portacoltelli della Leitz  
 \* HU Csak Leitz gyártmányú késfejekhez használható

EN Blanks with crossgroove and microfinish  
 DE Blanketts mit Quernut und Microfinish  
 FR Plaquettes avec rainure transversale et microfinish  
 IT Placchette con scanalatura e microfinish  
 HU Hosszbordás mikrosziszolt lapkák/microfinish

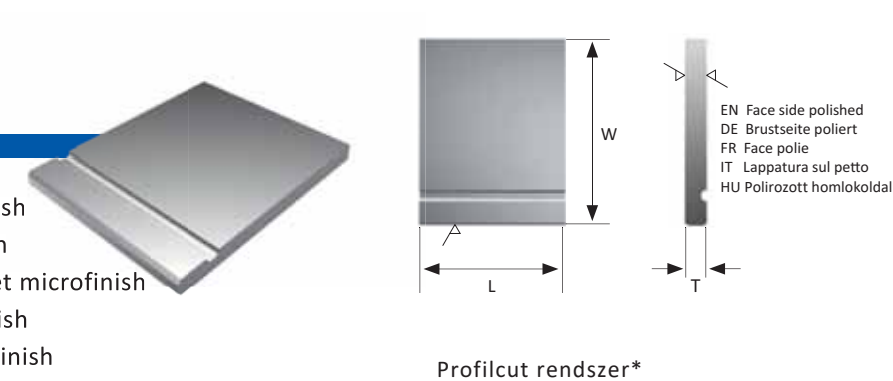

L mm	W mm	T mm	T04F-CR	T10MG
165.0	16.5	2.0	032154	041225
165.0	22.5	2.0	032162	041226
165.0	25.5	2.0	032163	041227
165.0	27.9	2.0	032164	041228
165.0	30.6	2.0	032165	041229
165.0	34.0	2.0	032167	041231

EN Blanks for profiling - Without bores  
 DE Blanketts zum Profilieren - Ohne Bohrung  
 FR Plaquettes à profiler - Sans trous  
 IT Placchette da profilare - Senza fori  
 HU Profilozható nyerslapkák - Furatok nélkül

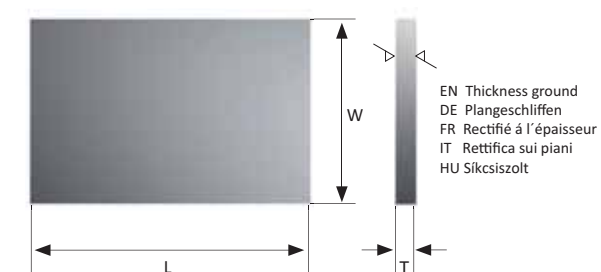

L mm	W mm	T mm	T04F-CR
40.0	15.0	2.0	018651
40.0	25.0	2.0	018620
40.0	30.0	2.0	018633
40.0	35.0	2.0	018623
48.0	15.0	2.0	018655
48.0	20.0	2.0	018636
48.0	25.0	2.0	018640
50.0	45.0	2.0	018659
50.0	25.4	1.5	018343

\* EN For use in Leitz-cutterheads only  
 \* DE Nur zur Verwendung in Messerköpfen der Firma Leitz  
 \* FR Utilisation limitée aux porte outils de l'entreprise Leitz  
 \* IT Da usare solo su teste portacoltelli della Leitz  
 \* HU Csak Leitz gyártmányú késfejekhez használható



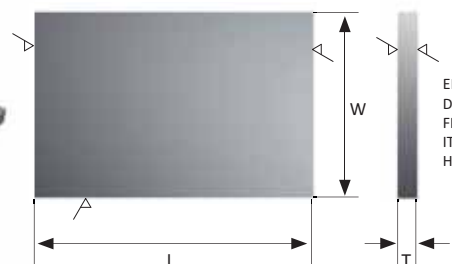
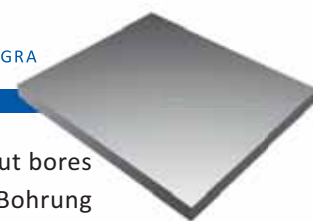

EN 3 sides ground  
 DE 3 Seiten geschliffen  
 FR Rectifié à 3 côtés  
 IT Rettificati su 3 lati  
 HU 3 oldal síksziszolt

- EN Blanks for profiling - Without bores  
 DE Blanketts zum Profilieren - Ohne Bohrung  
 FR Plaquettes à profiler - Sans trous  
 IT Placchette da profilare - Senza fori  
 HU Profilozható nyerslapkák - Furatok nélkül

L mm	W mm	T mm	T04MG-CR	T10MG
15.0	15.5	2.0	107755	107795
15.0	20.5	2.0	107756	107796
20.0	20.5	2.0	107757	107797
20.0	25.5	2.0	107758	107798
20.0	30.5	2.0	107759	107799
20.0	35.5	2.0	107760	107800
25.0	20.5	2.0	107761	107801
25.0	25.5	2.0	107762	107802
25.0	30.5	2.0	107763	107803
25.0	35.5	2.0	107764	107804
30.0	20.5	2.0	107765	107805
30.0	25.5	2.0	107766	107806
30.0	30.5	2.0	107767	107807
30.0	35.5	2.0	107768	107808
30.0	40.5	2.0	107769	107809
35.0	20.5	2.0	107770	107810
35.0	25.5	2.0	107771	107811
35.0	30.5	2.0	107772	107812
35.0	35.5	2.0	107773	107813
35.0	40.5	2.0	107774	107814
40.0	20.5	2.0	107775	107815
40.0	25.5	2.0	107776	107816
40.0	30.5	2.0	107777	107817
40.0	35.5	2.0	107778	107818
40.0	40.5	2.0	107779	107819
45.0	30.5	2.0	107780	107820
45.0	35.5	2.0	107781	107821
50.0	20.5	2.0	107782	107822
50.0	25.5	2.0	107783	107823
50.0	30.5	2.0	107784	107824
50.0	35.5	2.0	107785	107826
50.0	40.5	2.0	107786	107827
60.0	20.5	2.0	107787	107828
60.0	25.5	2.0	107788	107829
60.0	30.5	2.0	107789	107830
60.0	40.5	2.0	107790	107831
60.0	45.5	2.0	107791	107832
80.0	25.5	2.0	107792	107833
80.0	35.5	2.0	107793	107835
80.0	45.5	2.0	107794	107836

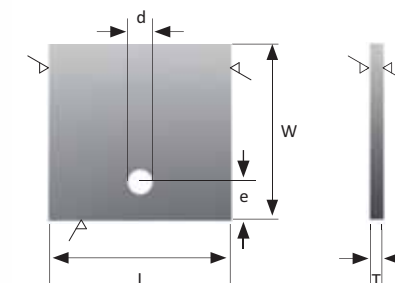
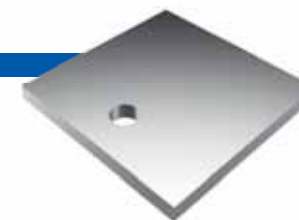







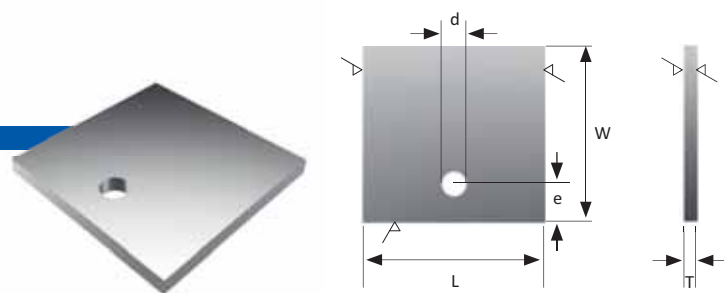

- EN Preprofiled blanks  
 DE Vorprofilierter Blanketts  
 FR Plaquettes préprofilées  
 IT Placchette presagomate  
 HU Előprofilozott nyerslapka

	L mm	W mm	T mm	d mm	e mm	R mm	T04F-CR
	13.0	16.0	2.0	4.0		2-4	015177
	20.0	21.0	2.0	4.0		5-8	015181
	26.0	24.0	2.0	4.0		9-13	015185
	12.0	14.5	2.0	4.0	6.0		017731
	12.0	18.0	2.0	4.0	6.0		019815
	16.0	17.5	2.0	3.0	5.0	2-6	017550
	16.0	17.5	2.0	3.5	5.0	2-6	015235
	16.0	17.5	2.0	4.0	5.0	2-6	015242
	16.0	17.5	2.0	4.4	5.0	2-6	051310
	20.0	17.5	2.0	4.0	6.0	2-8	015239
	20.0	20.5	2.0	4.0	6.3	2-6	015245
	16.0	17.5	2.0	4.4	5.4	2-6	015243
	24.0	20.4	2.0	4.2	6.3	2-6	015247
	15.0	15.0	2.0	4.0	6.0		022306







EN Profiled standard blanks  
 DE Profilierte Standardblanketts  
 FR Plaquettes standard profilées  
 IT Placchette profilate standard  
 HU Profilos standard nyerslapkák

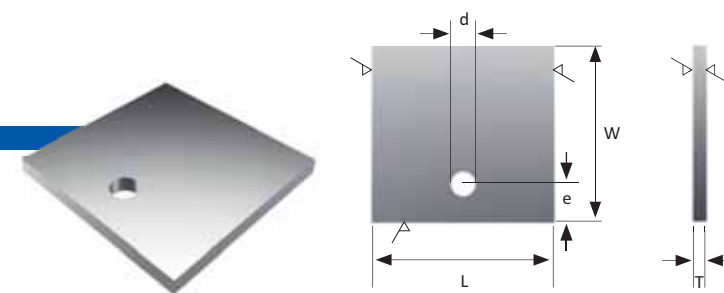

	L mm	W mm	T mm	d mm	R mm	T04F-CR
	13.0	16.0	2.0	4.0	2.0	032836
	13.0	16.0	2.0	4.0	3.0	032837
	13.0	16.0	2.0	4.0	4.0	032838
	20.0	21.0	2.0	4.0	5.0	032839
	20.0	21.0	2.0	4.0	6.0	032840
	20.0	21.0	2.0	4.0	8.0	032842
	26.0	24.0	2.0	4.0	10.0	032844
	26.0	24.0	2.0	4.0	12.0	032846
	12.0	12.0	1.5	4.0	2.0	016426
	12.0	12.0	1.5	4.0	3.0	016427
	16.0	17.5	2.0	3.0	3.0	016516
	16.0	17.5	2.0	3.0	5.0	016519
	16.0	17.5	2.0	3.5	2.0	016469
	16.0	17.5	2.0	3.5	3.0	016470
	16.0	17.5	2.0	3.5	4.0	016472
	16.0	17.5	2.0	3.5	5.0	016473
	16.0	17.5	2.0	3.5	6.0	016474
	16.0	17.5	2.0	4.0	2.0	016477
	16.0	17.5	2.0	4.0	3.0	016478
	16.0	17.5	2.0	4.0	4.0	016479
16.0	17.5	2.0	4.0	5.0	016480	
	16.0	17.5	2.0	4.4	2.0	016510
	16.0	17.5	2.0	4.4	3.0	016511
	16.0	17.5	2.0	4.4	4.0	016512
	16.0	17.5	2.0	4.4	5.0	016513
	22.3	14.0	2.0	4.8	1.0	129662
	22.3	14.0	2.0	4.8	1.5	119755
	22.3	14.0	2.0	4.8	2.0	107512
	22.3	14.0	2.0	4.8	3.0	108850
	22.3	14.0	2.0	4.8	1.0	129663
	22.3	14.0	2.0	4.8	1.5	119756
	22.3	14.0	2.0	4.8	2.0	107513
	22.3	14.0	2.0	4.8	3.0	108852

EN Profiled standard blanks  
 DE Profilierte Standardblanketts  
 FR Plaquettes standard profilées  
 IT Placchette profilate standard  
 HU Profilos standard nyerslapkák



	L mm	W mm	T mm	d mm	R mm	T04F-CR
	15.0	14.5	2.0	4.0	2.0	022305
	15.0	14.5	2.0	4.0	2.5	033939
	15.0	14.5	2.0	4.0	3.0	022308
	16.1	14.0	2.0	5.0	2.0	046693
	16.1	14.0	2.0	5.0	3.0	049986
	15.0	14.5	2.0	4.0	2.0	022307
	15.0	14.5	2.0	4.0	2.5	033940
	15.0	14.5	2.0	4.0	3.0	022309
	16.1	14.0	2.0	5.0	2.0	046694
	16.1	14.0	2.0	5.0	3.0	049987
	16.1	14.0	2.0	5.0	3.0	049987
	12.0	14.5	2.0	4.0	2.0	021044
	12.0	14.5	2.0	4.0	2.5	020397
	12.0	14.5	2.0	4.0	3.0	020620
	19.6	15.2	2.0	4.0	2.0	033963
	19.6	15.2	2.0	4.0	3.0	033967
	12.0	14.5	2.0	4.0	2.0	021045
	12.0	14.5	2.0	4.0	2.5	020396
	12.0	14.5	2.0	4.0	3.0	020619
	19.6	15.2	2.0	4.0	2.0	033966
	19.6	15.2	2.0	4.0	3.0	033968

EN Profiled standard blanks  
 DE Profilierte Standardblanketts  
 FR Plaquettes standard profilées  
 IT Placchette profilate standard  
 HU Profilos standard nyerslapkák

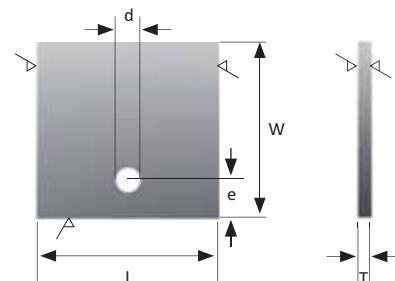
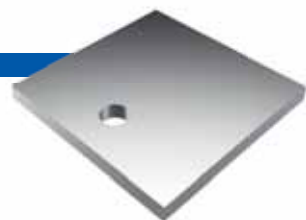

	L mm	W mm	T mm	d mm	R mm	A°	T04F-CR
	20.0	16.0	2.0	3.0	3.0		033311
	30.0	14.0	2.0	4.0	2.5		033313
	30.0	14.0	2.0	4.0	3.0		033314
	20.0	16.0	2.0	3.0	3.0		033315
	30.0	14.0	2.0	4.0	2.5		033317
	30.0	14.0	2.0	4.0	3.0		033318
	12.0	12.0	1.5	4.0	45°		033319
	16.0	17.5	2.0	4.0	45°		032964
	16.0	17.5	2.0	4.4	45°		033324
	16.0	17.5	2.0	3.5	45°		015237
	20.0	12.0	2.0	4.0	1.0	6°	032984
	20.0	12.0	2.0	4.0	1.0	15°	050309
	20.0	12.0	2.0	4.0	2.0	6°	016419
	20.0	12.0	2.0	4.0	2.0	15°	050311
	20.0	12.0	2.0	4.0	3.0	6°	016420
	20.0	12.0	2.0	4.0	3.0	15°	050313
	12.7	12.7	3.2		2.0		035041
	12.7	12.7	3.2		3.0		037922
	19.5	9.0	1.5	4.0	2.0		033117
	19.5	9.0	1.5	4.0	3.0		033097
	19.5	9.0	1.5	4.0	4.0		033098
	19.5	9.0	1.5	4.0	5.0		033099
	30.0	22.5	3.0				020272
	55.0	25.0	3.0				020502
	30.0	22.5	3.0				020273
	55.0	25.0	3.0				020503

EN Packing boxes  
 DE Verpackungsschachteln  
 FR Caisses d'emballage  
 IT Contenitori per imballo  
 HU Csomagoló dobozok

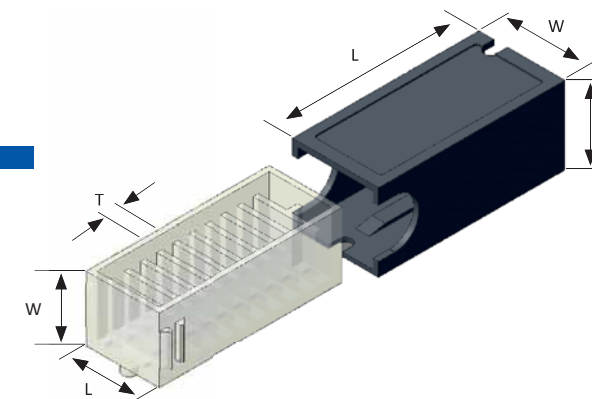

EN in anthracite DE in anthrazit FR en anthracite IT in antracite HU antracit színben	External dimension box Außenmaß Schachtel Dimension externe de boîte Dimensione esterna Doboz külső méretek			Art-No.	Maximum knife dimension Maximales Messermaß Dimension maximum de couteau Dimensione massima della lama Legnagyobb késméret			Pieces Stück Unités Unità Darabszám
	L mm	W mm	T mm		L mm	W mm	T mm	
	69	31.8	29.2	106393	23	23	4	10
	69	41.8	39.2	114845	33	33	4	10
	69	46.8	44.2	106404	38	38	4	10
	69	54.8	52.2	106856	46	46	4	10
	69	61.8	49.2	114844	53	43	4	10
	69	73.6	49.2	114843	65	43	4	10
	69	73.6	71.2	106858	65	65	4	10





EN Saw tips and strobe blanks  
DE Sägezähne und Wischerblätter  
FR Dents de scie et racleurs  
IT Dentelli per lame e barrette per rasanti  
HU Fűrészfogak és tisztítófogak

DE Hartmetallsägezähne für Kreissägen  
 FR Dents de scie pour scies circulaires  
 IT Dentelli per lame circolari  
 HU Vídia fűrészfogak körfűrész tárcsákhoz

EN Carbide saw tips for circular saws  
 DE Hartmetallsägezähne für Kreissägen  
 FR Dents de scie pour scies circulaires  
 IT Dentelli per lame circolari  
 HU Vídia fűrészfogak körfűrész tárcsákhoz

EN Carbide saw tips for circular saws  
 DE Hartmetallsägezähne für Kreissägen  
 FR Dents de scie pour scies circulaires  
 IT Dentelli per lame circolari  
 HU Vídia fűrészfogak körfűrész tárcsákhoz

EN Strobe blanks  
 DE Wischerblätter  
 FR Racleurs  
 IT Barrette per rasanti  
 HU Tisztítófogak

EN Strobe blanks  
 DE Wischerblätter  
 FR Racleurs  
 IT Barrette per rasanti  
 HU Tisztítófogak

EN Brazing alloys and fluxes  
 DE Lot und Flussmittel  
 FR Alliages et flux de brasage  
 IT Leghe brasanti e disossidanti  
 HU Forraszanyagok és folyatók

metric  
 métrique  
 metrikus

"CW Style"  
 hüvelyk

"W Style"  
 hüvelyk

metric  
 metrisch  
 métrique  
 metrico  
 metrikus

hüvelyk

72 - 76

77 - 80 EN Saw tips and strobe blanks  
 DE Sägezähne und Wischerblätter  
 FR Dents de scie et racleurs  
 IT Dentelli per lame e barrette per rasanti

81 - 82 HU Fűrészfogak és tisztítófogak

83			
84			
84 - 85			

EN For saw tips in metalworking grades please refer to our catalog "Metal and composite material working".  
 DE Für Sägezähne in Metallbearbeitungssorten beachten Sie bitte unseren Katalog "Metall- und Verbundwerkstoffbearbeitung".  
 FR Pour les dents de scie en nuances d'usage de métaux s.v.p. consultez notre catalogue "Usinage de métaux et de matériaux composites".  
 IT Per i dentelli per lame per la meccanica, consultare il nostro catalogo "Lavorazione di metalli e materiali compositi".  
 HU Fémipari kategóriájú fűrészfogakért nézze meg "Fém- és kompozit anyagok megmunkálása" katalógusunkat.



- EN Carbide saw tips - Carbide grades and their applications  
 DE Hartmetallsägezähne - Hartmetallsorten und ihre Anwendungen  
 FR Dents de scie - Les nuances de carbures et leurs applications  
 IT Dentelli per lame - I tipi di metallo duro e le loro applicazioni  
 HU Vídia fűrészfogak - Vídia kategóriák és felhasználásuk

EN TIGRA grade	ISO	USA	Hardness	Toughness	Bending strength	Aluminum	HDF	MDF	Chipboard	Hardwood	Softwood	Main usage
DE TIGRA - Sorte	ISO	USA	Härte	Zähigkeit	Biegebruchfestigkeit	Aluminium	HDF	MDF	Spanplatte	Hartholz	Weichholz	Hauptverwendung
FR Nuance TIGRA	ISO	USA	Dureté	Ténacité	Résistance à la flexion	Aluminium	HDF	MDF	Panneaux de particule	Bois dur	Bois tendre	Usage principal
IT Tipo TIGRA	ISO	Stati uniti	Durezza	Tenacità	Resistenza flessionale	Alluminio	HDF	MDF	Truciolare	Legno duro	Legno tenero	Usi principali
HU TIGRA kategória	ISO	EE.UU.	Keménység	Szívósság	Hajlítószilárdság	Aluminium	HDF	MDF	Forgácslap	Keményfa	Puhafa	Fő alkalmazási terület
T03MG-CR	K01	C4++	↑	↓	↗	○	✓	✓	✓	☐	☐	EN MDF, HDF DE MDF, HDF FR MDF, HDF IT MDF, HDF HU MDF, HDF
T03F-CR	K01	C4+	↗	↗	↗	✓	○	✓	✓	○	☐	EN MDF, chipboard, aluminum DE MDF, Spanplatte, Aluminium FR MDF, panneaux, aluminium IT MDF, truciolare, alluminio HU MDF, forgácslap, aluminium
T06F-CR UNIVERSAL	K10	C3	→	→	→	✓	○	○	✓	✓	✓	EN Universal use DE Universeller Einsatz FR Utilisation universelle IT Uso universale HU Univerzális felhasználás
T07MF-CR	K20 - K30	C2 - C3	→	↗	→	✓	○	○	✓	✓	✓	EN Universal use (USA) DE Universeller Einsatz (USA) FR Utilisation universelle (ÉTATS-UNIS) IT Uso universale (USA) HU Univerzális felhasználás (USA)
T07MF-W	K20 - K30	C2 - C3	↗	↗	↗	○	☐	☐	○	✓	✓	EN Inexpensive saw blades, wood DE Preiswerte Sägeblätter, Holz FR Lames de scie peu coûteuses, bois IT Lame a basso costo, legno HU Alacsony árú fűrészek, fához
T10MG	K10 - K40	C3+	↗	↗	↑	○	☐	☐	☐	✓	✓	EN Softwood and hardwood DE Weich- und Hartholz FR Bois tendre et dur IT Legni teneri e duri HU Puhafa és keményfa
T12M-CR	K10 - K40	C3+	↗	↗	↑	○	☐	☐	☐	✓	✓	EN Saw mills, frozen wood DE Sägewerke, gefrorenes Holz FR Scieries, bois congelé IT Segherie, legno congelato HU Fűrészüzemek, megfagyott fa
T15C	> K40	Nail Cut	↓	↑	↑	☐	☐	☐	☐	○	✓	EN Nail cutting, recycling DE Holz mit Nägeln, Recycling FR Couper ongles, recyclage IT Legno con chiodi, riciclato HU Szeg vágás, újrahasznosítás

CR = Co + Ni + Cr = corrosion resistant - korrosionsbeständig - anti-corrosif - inossidabile - korrózióálló

EN For technical data, please refer to the pages 4-5.  
 DE Die technischen Daten entnehmen Sie bitte den Seiten 4-5.  
 FR Pour les données techniques, veuillez voir aux pages 4-5.

IT Per i dati tecnici, fare riferimento alle pagine 4-5.  
 HU A műszaki adatokat a 4-5. oldalon találja.

✓ kiváló teljesítőképesség  
 ↗ nagyon jó teljesítményű  
 ○ elfogadható  
 ☐ nem alkalmas



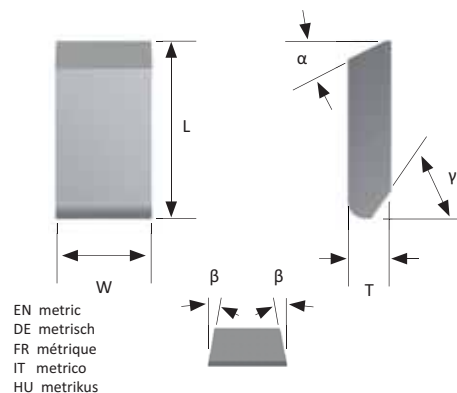

EN metric  
DE metrisch  
FR métrique  
IT metrico  
HU metrikus

EN Carbide saw tips for circular saws  
DE Hartmetallsägezähne für Kreissägen  
FR Dents de scie pour scies circulaires  
IT Dentelli per lame circolari  
HU Vídia fűrészfogak körfűrész tárcsákhoz

L mm	W mm	T mm	$\alpha$	$\beta$	$\gamma$	T03MG-CR	T03F-CR	T06F-CR
6.5	2.5	2.0	27	5	56		111682	111687
6.5	3.0	2.0	27	5	56		111683	111688
6.5	3.2	2.0	27	5	56	116373		118303
6.5	3.5	2.0	27	5	56		111684	111689
6.5	3.8	2.0	27	5	56		111685	111690
6.5	4.0	2.0	27	5	56			120254
6.5	4.5	2.0	27	5	56			120255

L mm	W mm	T mm	$\alpha$	$\beta$	$\gamma$	T03MG-CR	T03F-CR	T06F-CR	T07MF-W
8.0	2.5	2.3	27	5	70		121627	121535	152660
8.0	2.8	2.3	27	5	70		111632	111649	
8.0	2.9	2.3	27	5	70		111633	111650	
8.0	3.0	2.3	27	5	70		111634	111651	
8.0	3.1	2.3	27	5	70		115551	115550	152661
8.0	3.3	2.3	27	5	70		111635	111652	
8.0	3.4	2.3	27	5	70	121831	121832	116207	
8.0	3.5	2.3	27	5	70	114016	111636	111653	152662
8.0	3.6	2.3	27	5	70	114017	111637	111654	
8.0	3.7	2.3	27	5	70				
8.0	3.8	2.3	27	5	70	114018	111638	111655	152663
8.0	4.0	2.3	27	5	70	114019	111639	111656	146493
8.0	4.1	2.3	27	5	70			124214	
8.0	4.3	2.3	27	5	70	114020	111640	111657	152665
8.0	4.4	2.3	27	5	70	114021	111641	111658	
8.0	4.5	2.3	27	5	70		111642	111659	146494
8.0	4.8	2.3	27	5	70		111643	111660	
8.0	5.0	2.3	27	5	70		111644	111661	
8.0	5.2	2.3	27	5	70		111645	111662	
8.0	5.5	2.3	27	5	70		111646	111663	
8.0	6.0	2.3	27	5	70		139403		

L mm	W mm	T mm	$\alpha$	$\beta$	$\gamma$	T03MG-CR	T03F-CR
8.0	4.3	3.0	30	5	60	142730	142743
8.0	4.8	3.0	30	5	60	142732	142741
8.0	5.0	3.0	30	5	60	142733	142738
8.0	6.0	3.0	30	5	60	156677	133718
8.0	6.5	3.0	30	5	60	142735	133719

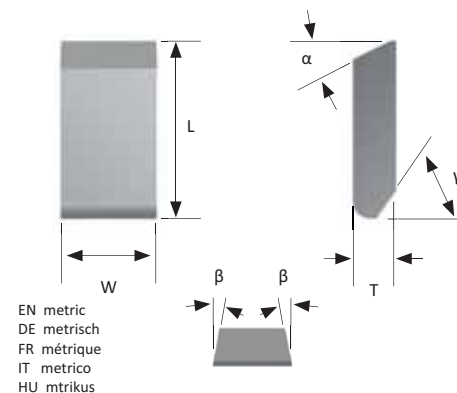

EN metric  
DE metrisch  
FR métrique  
IT metrico  
HU mtrikus

EN Carbide saw tips for circular saws  
DE Hartmetallsägezähne für Kreissägen  
FR Dents de scie pour scies circulaires  
IT Dentelli per lame circolari  
HU Vídia fűrészfogak körfűrész tárcsákhoz

L mm	W mm	T mm	$\alpha$	$\beta$	$\gamma$	T03MG-CR	T06F-CR	T07MF-W
8.5	2.2	2.5	27	5	70		130208	
8.5	2.5	2.5	27	5	70	114027	111621	
8.5	3.0	2.5	27	5	70	114028	111622	
8.5	3.3	2.5	27	5	70	114029	111623	
8.5	3.4	2.5	27	5	70	124609	128510	
8.5	3.5	2.5	27	5	70	120964	120961	
8.5	3.6	2.5	27	5	70	114030	111624	152666
8.5	3.8	2.5	27	5	70	114032	111626	152667
8.5	4.0	2.5	27	5	70	114033	111627	
8.5	4.2	2.5	27	5	70	128976	119323	152668
8.5	4.3	2.5	27	5	70	124204	124694	
8.5	4.5	2.5	27	5	70	114034	111628	152669
8.5	4.6	2.5	27	5	70		119324	
8.5	5.0	2.5	27	5	70	114035	111629	
8.5	5.5	2.5	27	5	70	120972	120403	

L mm	W mm	T mm	$\alpha$	$\beta$	$\gamma$	T03MG-CR	T03F-CR	T06F-CR
8.5	3.0	3.2	30	3.5	45	166814		163371
8.5	3.8	3.2	30	3.5	45		163833	
8.5	4.1	3.2	30	3.5	45		163835	
8.5	4.5	3.2	30	3.5	45	159821		
8.5	5.0	3.2	30	3.5	45		163836	166329
8.5	5.6	3.2	30	3.5	45		163837	
8.5	6.2	3.2	30	3.5	45	159819		

L mm	W mm	T mm	$\alpha$	$\beta$	$\gamma$	T03MG-CR	T06F-CR
9.0	3.5	2.7	27	5	70		111613
9.0	3.8	2.7	27	5	70		111615
9.0	4.2	2.7	27	5	70		111618
9.0	4.3	2.7	27	5	70		111619
9.0	4.7	2.7	27	5	70		111620
9.0	5.2	2.7	27	5	70		129638
9.0	5.3	2.7	27	5	70	129939	
9.0	5.5	2.7	27	5	70		126860
9.0	6.0	2.7	27	5	70		140846

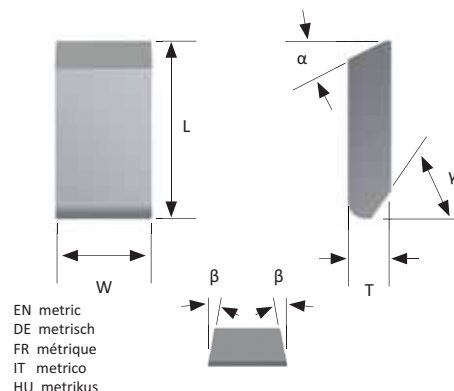

EN metric  
DE metrisch  
FR métrique  
IT metrico  
HU metrikus

EN Carbide saw tips for circular saws  
DE Hartmetallsägezähne für Kreissägen  
FR Dents de scie pour scies circulaires  
IT Dentelli per lame circolari  
HU Vídia fűrészfogak körfűrész tárcsákhoz

L mm	W mm	T mm	$\alpha$	$\beta$	$\gamma$	T06F-CR	T07MF-W
10.5	3.0	2.5	27	5	70	111578	
10.5	3.3	2.5	27	5	70	112437	
10.5	3.5	2.5	27	5	70	111580	145071
10.5	3.6	2.5	27	5	70	111581	
10.5	3.8	2.5	27	5	70	111583	152670
10.5	4.0	2.5	27	5	70	111584	148043
10.5	4.1	2.5	27	5	70	134345	
10.5	4.3	2.5	27	5	70	111585	
10.5	4.5	2.5	27	5	70	111586	147520
10.5	5.0	2.5	27	5	70	111587	152671
10.5	5.5	2.5	27	5	70	111588	
10.5	6.5	2.5	27	5	70	111589	

L mm	W mm	T mm	$\alpha$	$\beta$	$\gamma$	T03MG-CR	T03F-CR	T06F-CR	T07MF-CR	T07MF-W
10.5	3.5	3.0	27	5	65	114060	111489	111508	111546	146486
10.5	3.6	3.0	27	5	65	114061	111490	111509	111547	
10.5	3.8	3.0	27	5	65	114062	111491	111510	111548	
10.5	3.9	3.0	27	5	65			121540		
10.5	4.1	3.0	27	5	65	114063	111492	111511	111549	152672
10.5	4.3	3.0	27	5	65	114064	111493	111512	111550	146487
10.5	4.5	3.0	27	5	65	114065	111494	111513	111551	152673
10.5	4.6	3.0	27	5	65	114066	111495	111514	111552	
10.5	4.8	3.0	27	5	65	114068	111497	111516	111554	
10.5	5.0	3.0	27	5	65	114069	111498	111517	111555	152674
10.5	5.3	3.0	27	5	65	114070	111499	111518	111556	
10.5	5.5	3.0	27	5	65	114071	111500	111519	111557	152675
10.5	6.0	3.0	27	5	65	114073	111502	111521	111559	
10.5	6.5	3.0	27	5	65	114074	111503	111522	111560	
10.5	7.0	3.0	27	5	65			111523		
10.5	8.5	3.0	27	5	65			111524		
10.5	10.5	3.0	27	5	65			111525		

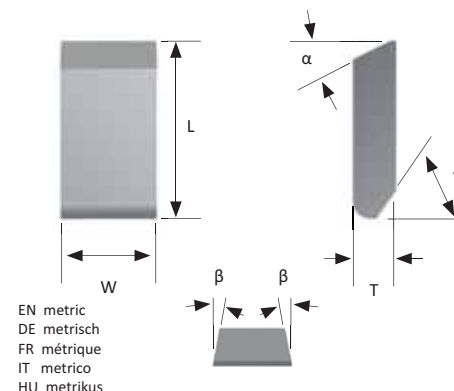

EN metric  
DE metrisch  
FR métrique  
IT metrico  
HU metrikus

EN Carbide saw tips for circular saws  
DE Hartmetallsägezähne für Kreissägen  
FR Dents de scie pour scies circulaires  
IT Dentelli per lame circolari  
HU Vídia fűrészfogak körfűrész tárcsákhoz

L mm	W mm	T mm	$\alpha$	$\beta$	$\gamma$	T03MG-CR	T03F-CR	T06F-CR	T07MF-CR	T07MF-W
10.5	3.5	3.5	27	5	60			111449		145072
10.5	4.0	3.5	27	5	60			111450	112415	145991
10.5	4.1	3.5	27	5	60			111451		
10.5	4.3	3.5	27	5	60			111452		
10.5	4.4	3.5	27	5	60					
10.5	4.5	3.5	27	5	60		111433	111453	112418	145992
10.5	4.7	3.5	27	5	60		111434	111454	112419	
10.5	4.8	3.5	27	5	60	122004	111435	111455	112420	
10.5	5.0	3.5	27	5	60	126206	111436	111456	112421	145070
10.5	5.3	3.5	27	5	60	126913		111457		
10.5	5.5	3.5	27	5	60		111438	111458	112423	145069
10.5	5.8	3.5	27	5	60		111439	111459	112424	
10.5	6.0	3.5	27	5	60	122005	111440	111460	112425	145995
10.5	6.5	3.5	27	5	60		111441	111461	112426	144793
10.5	7.0	3.5	27	5	60			111462		
10.5	7.5	3.5	27	5	60			111463		146485
10.5	8.5	3.5	27	5	60				112430	
10.5	9.0	3.5	27	5	60				112431	
10.5	10.0	3.5	27	5	60				112432	
10.5	11.5	3.5	27	5	60				118891	

L mm	W mm	T mm	$\alpha$	$\beta$	$\gamma$	T03MG-CR	T03F-CR	T07MF-CR	T12M-CR	T07MF-W
13.0	4.2	4.0	30	5	60				126246	
13.0	4.9	4.0	30	5	60			111419		
13.0	5.2	4.0	30	5	60				126247	152676
13.0	5.4	4.0	30	5	60	124194	111411	111420		
13.0	5.8	4.0	30	5	60		111412	111421	119611	
13.0	6.0	4.0	30	5	60	127248	111413	111422		152677
13.0	6.3	4.0	30	5	60	124100	111414	111423	126248	
13.0	6.5	4.0	30	5	60	120620	111415	111424		152678
13.0	6.7	4.0	30	5	60	123406	111416	111425		
13.0	7.0	4.0	30	5	60		111417	111426		152679
13.0	7.5	4.0	30	5	60		111418	111427		152680
13.0	8.5	4.0	30	5	60			104897		156302

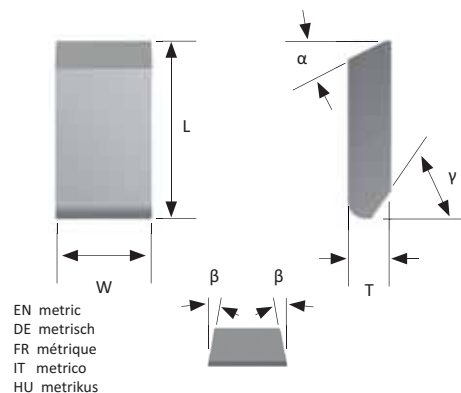

EN Carbide saw tips for circular saws  
DE Hartmetallsägezähne für Kreissägen  
FR Dents de scie pour scies circulaires  
IT Dentelli per lame circolari  
HU Vídia fűrészfogak körfűrész tárcsákhoz

	L mm	W mm	T mm	$\alpha$	$\beta$	$\gamma$	T07MF-CR
	14.5	5.0	4.0	30	0	70	111390
	14.5	9.0	4.0	30	0	70	111397
	14.5	10.0	4.0	30	0	70	111398
	14.5	11.0	4.0	30	0	70	111400
	14.5	12.0	4.0	30	0	70	111401
	14.5	13.0	4.0	30	0	70	111402
	14.5	14.0	4.0	30	0	70	111403
	14.5	16.0	4.0	30	0	70	111405

	L mm	W mm	T mm	$\alpha$	$\beta$	$\gamma$	T03MG-CR	T03F-CR
	8.5	3.5	2.5	25	4	70	149281	
	8.5	3.7	2.6	25	7	70	151920	144429
	10.5	3.7	2.6	25	7	73	124256	124257
	10.5	4.0	2.6	25	7	73		162832

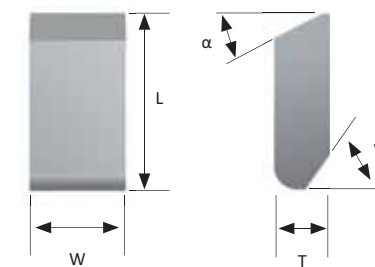

EN Carbide saw tips for circular saws  
DE Hartmetallsägezähne für Kreissägen  
FR Dents de scie pour scies circulaires  
IT Dentelli per lame circolari  
HU Vídia fűrészfogak körfűrész tárcsákhoz

**CW Style**  
hüvelyk

CWB	L inch	mm	W inch	mm	T inch	mm	$\alpha$	$\beta$	$\gamma$	T10MG
7100	0.281	7.1	0.100	2.5	0.078	2.0	30	0	60	113836
7120	0.281	7.1	0.120	3.0	0.078	2.0	30	0	60	113838
7135	0.281	7.1	0.135	3.4	0.078	2.0	30	0	60	113839
7150	0.281	7.1	0.150	3.8	0.078	2.0	30	0	60	113840
7165	0.281	7.1	0.165	4.2	0.078	2.0	30	0	60	113841
7180	0.281	7.1	0.180	4.6	0.078	2.0	30	0	60	113843
7195	0.281	7.1	0.195	5.0	0.078	2.0	30	0	60	113844
7200	0.281	7.1	0.200	5.1	0.078	2.0	30	0	60	113845

CWD	L inch	mm	W inch	mm	T inch	mm	$\alpha$	$\beta$	$\gamma$	T03F-CR	T07MF-CR	T10MG
7100	0.312	7.9	0.100	2.5	0.093	2.4	30	0	60	111288	111311	112629
7110	0.312	7.9	0.110	2.8	0.093	2.4	30	0	60	111289	111312	112630
7120	0.312	7.9	0.120	3.0	0.093	2.4	30	0	60	111291	111314	112632
7125	0.312	7.9	0.125	3.2	0.093	2.4	30	0	60	111292	111315	112633
7135	0.312	7.9	0.135	3.4	0.093	2.4	30	0	60	111294	111317	112635
7140	0.312	7.9	0.140	3.6	0.093	2.4	30	0	60	111295	111318	112636
7150	0.312	7.9	0.150	3.8	0.093	2.4	30	0	60	111296	111319	112637
7165	0.312	7.9	0.165	4.2	0.093	2.4	30	0	60	111298	111321	112639
7170	0.312	7.9	0.170	4.3	0.093	2.4	30	0	60	111299	111322	112640
7180	0.312	7.9	0.180	4.6	0.093	2.4	30	0	60	111301	111324	112642
7185	0.312	7.9	0.185	4.7	0.093	2.4	30	0	60	111302	111325	112643
7200	0.312	7.9	0.200	5.1	0.093	2.4	30	0	60	111304	111327	112645
7215	0.312	7.9	0.215	5.5	0.093	2.4	30	0	60	111305	111328	112646
7220	0.312	7.9	0.220	5.6	0.093	2.4	30	0	60	111306	111329	112647
7230	0.312	7.9	0.230	5.8	0.093	2.4	30	0	60	111307	111330	112648
7250	0.312	7.9	0.250	6.4	0.093	2.4	30	0	60	111309	111332	112650
7280	0.312	7.9	0.280	7.1	0.093	2.4	30	0	60	112653	112654	112651
7312	0.312	7.9	0.312	7.9	0.093	2.4	30	0	60	111310	111333	112652

CWE	L inch	mm	W inch	mm	T inch	mm	$\alpha$	$\beta$	$\gamma$	T10MG
7140	0.375	9.5	0.140	3.6	0.093	2.4	30	0	60	111369
7150	0.375	9.5	0.150	3.8	0.093	2.4	30	0	60	111370
7165	0.375	9.5	0.165	4.2	0.093	2.4	30	0	60	111371
7185	0.375	9.5	0.185	4.7	0.093	2.4	30	0	60	111372
7200	0.375	9.5	0.200	5.1	0.093	2.4	30	0	60	111373
7215	0.375	9.5	0.215	5.5	0.093	2.4	30	0	60	111374
7225	0.375	9.5	0.225	5.7	0.093	2.4	30	0	60	112659
7230	0.375	9.5	0.230	5.8	0.093	2.4	30	0	60	111375
7250	0.375	9.5	0.250	6.4	0.093	2.4	30	0	60	111376
7281	0.375	9.5	0.281	7.1	0.093	2.4	30	0	60	111377
7312	0.375	9.5	0.312	7.9	0.093	2.4	30	0	60	111378



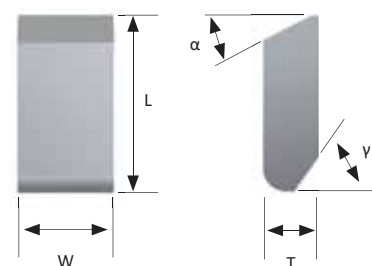

**CW Style**  
hüvelyk

EN Carbide saw tips for circular saws  
 DE Hartmetallsägezähne für Kreissägen  
 FR Dents de scie pour scies circulaires  
 IT Dentelli per lame circolari  
 HU Vídia fűrészfogak körfűrész tárcsákhoz

CWF	L		W		T		α	β	γ	T10MG	T12M-CR	T07MF-W
	inch	mm	inch	mm	inch	mm						
7130	0.500	12.7	0.130	3.3	0.125	3.2	35	0	70	111229	109395	152704
7140	0.500	12.7	0.140	3.6	0.125	3.2	35	0	70	111230	109397	152705
7150	0.500	12.7	0.150	3.8	0.125	3.2	35	0	70	111231	109399	152706
7160	0.500	12.7	0.160	4.1	0.125	3.2	35	0	70	111232	109400	152707
7165	0.500	12.7	0.165	4.2	0.125	3.2	35	0	70	111233	109401	152708
7170	0.500	12.7	0.170	4.3	0.125	3.2	35	0	70	111234	109402	152709
7180	0.500	12.7	0.180	4.6	0.125	3.2	35	0	70	111235	109403	152712
7190	0.500	12.7	0.190	4.8	0.125	3.2	35	0	70	111236	109405	152713
7200	0.500	12.7	0.200	5.1	0.125	3.2	35	0	70	111237	109406	152714
7210	0.500	12.7	0.210	5.3	0.125	3.2	35	0	70	111238	109407	152715
7215	0.500	12.7	0.215	5.5	0.125	3.2	35	0	70	111239	109408	152716
7220	0.500	12.7	0.220	5.6	0.125	3.2	35	0	70	111240	109409	152717
7230	0.500	12.7	0.230	5.8	0.125	3.2	35	0	70	111241	109410	152718
7240	0.500	12.7	0.240	6.1	0.125	3.2	35	0	70	111242	109412	152719
7250	0.500	12.7	0.250	6.4	0.125	3.2	35	0	70	111243	109413	152720
7260	0.500	12.7	0.260	6.6	0.125	3.2	35	0	70	111244	109414	152721
7270	0.500	12.7	0.270	6.9	0.125	3.2	35	0	70	111245	109416	152722
7275	0.500	12.7	0.275	7.0	0.125	3.2	35	0	70	111246	109417	152723
7280	0.500	12.7	0.280	7.1	0.125	3.2	35	0	70	111247	109418	152724
7290	0.500	12.7	0.290	7.4	0.125	3.2	35	0	70	111248	109419	152725
7310	0.500	12.7	0.310	7.9	0.125	3.2	35	0	70	111250	109421	152726
7312	0.500	12.7	0.312	7.9	0.125	3.2	35	0	70	111251	109422	152727
7330	0.500	12.7	0.330	8.4	0.125	3.2	35	0	70	111252	109424	152728

CWG	L		W		T		α	β	γ	T03F-CR	T10MG	T12M-CR	T15C	T07MF-W
	inch	mm	inch	mm	inch	mm								
7120	0.375	9.5	0.120	3.0	0.125	3.2	30	0	60	107350	111260	109438	107418	152758
7130	0.375	9.5	0.130	3.3	0.125	3.2	30	0	60	107352	111261	109440	107420	152759
7140	0.375	9.5	0.140	3.6	0.125	3.2	30	0	60	107354	111262	109442	107422	152760
7150	0.375	9.5	0.150	3.8	0.125	3.2	30	0	60	107355	111263	109443	107423	152761
7160	0.375	9.5	0.160	4.1	0.125	3.2	30	0	60	107356	111264	109444	107424	152762
7165	0.375	9.5	0.165	4.2	0.125	3.2	30	0	60	107357	111265	109445	107425	152763
7170	0.375	9.5	0.170	4.3	0.125	3.2	30	0	60	107358	111266	109446	107426	152764
7180	0.375	9.5	0.180	4.6	0.125	3.2	30	0	60	107359	111268	109447	107427	152765
7185	0.375	9.5	0.185	4.7	0.125	3.2	30	0	60	107360	111269	109448	107428	152766
7190	0.375	9.5	0.190	4.8	0.125	3.2	30	0	60	107361	111270	109449	107429	152767
7200	0.375	9.5	0.200	5.1	0.125	3.2	30	0	60	107363	111271	109451	107431	152768
7215	0.375	9.5	0.215	5.5	0.125	3.2	30	0	60	107365	111273	109453	107433	152769
7220	0.375	9.5	0.220	5.6	0.125	3.2	30	0	60	107366	111274	109454	107434	152770
7225	0.375	9.5	0.225	5.7	0.125	3.2	30	0	60	142758	142782	140490		152771
7230	0.375	9.5	0.230	5.8	0.125	3.2	30	0	60	107368	111275	109456	107436	152772

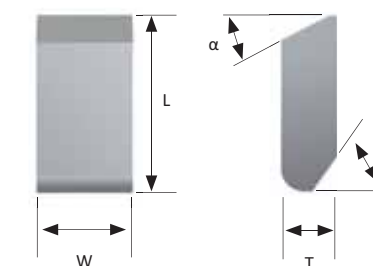

**CW Style**  
hüvelyk

EN Carbide saw tips for circular saws  
 DE Hartmetallsägezähne für Kreissägen  
 FR Dents de scie pour scies circulaires  
 IT Dentelli per lame circolari  
 HU Vídia fűrészfogak körfűrész tárcsákhoz

CWG	L		W		T		α	β	γ	T03F-CR	T10MG	T12M-CR	T15C	T07MF-W
	inch	mm	inch	mm	inch	mm								
7240	0.375	9.5	0.240	6.1	0.125	3.2	30	0	60	107369	111276	109457	107437	152773
7245	0.375	9.5	0.245	6.2	0.125	3.2	30	0	60	142784	142785	140489		152774
7250	0.375	9.5	0.250	6.4	0.125	3.2	30	0	60	107370	111277	109458	107438	152775
7260	0.375	9.5	0.260	6.6	0.125	3.2	30	0	60	107371	111278	109459	107439	152776
7270	0.375	9.5	0.270	6.9	0.125	3.2	30	0	60	107373	111279	109461	107441	152777
7280	0.375	9.5	0.280	7.1	0.125	3.2	30	0	60	107375	111281	109463	107443	152778
7300	0.375	9.5	0.300	7.6	0.125	3.2	30	0	60	107376	111282	109464	107444	152779
7312	0.375	9.5	0.312	7.9	0.125	3.2	30	0	60	107377	111284	109465	107445	152780
7335	0.375	9.5	0.335	8.5	0.125	3.2	30	0	60	142788	140925	142787		152781
7350	0.375	9.5	0.350	8.9	0.125	3.2	30	0	60	107380	111285	109468	111218	152782
7400	0.375	9.5	0.400	10.2	0.125	3.2	30	0	60	107379	111286	109467	107447	152783
7500	0.375	9.5	0.500	12.7	0.125	3.2	30	0	60	107381	111287	109469	107449	152784





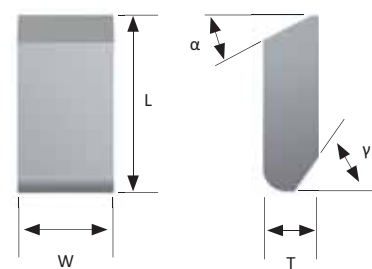





CWH	L		W		T		α	β	γ	T07MF-CR				
	inch	mm	inch	mm	inch	mm								
7135	0.344	8.7	0.135	3.4	0.125	3.2	30	0	60					114411
7150	0.344	8.7	0.150	3.8	0.125	3.2	30	0	60					114417
7165	0.344	8.7	0.165	4.2	0.125	3.2	30	0	60					114423
7185	0.344	8.7	0.185	4.7	0.125	3.2	30	0	60					114429
7200	0.344	8.7	0.200	5.1	0.125	3.2	30	0	60					114435
7215	0.344	8.7	0.215	5.5	0.125	3.2	30	0	60					114443
7220	0.344	8.7	0.220	5.6	0.125	3.2	30	0	60					114449
7230	0.344	8.7	0.230	5.8	0.125	3.2	30	0	60					114451
7250	0.344	8.7	0.250	6.4	0.125	3.2	30	0	60					114457

CWX	L		W		T		α	β	γ	T12M-CR				
	inch	mm	inch	mm	inch	mm								
7115	0.437	11.1	0.115	2.9	0.125	3.2	35	0	67					154123
7120	0.437	11.1	0.120	3.0	0.125	3.2	35	0	67					167104
7130	0.437	11.1	0.130	3.3	0.125	3.2	35	0	67					167105
7135	0.437	11.1	0.135	3.4	0.125	3.2	35	0	67					167106
7140	0.437	11.1	0.140	3.6	0.125	3.2	35	0	67					167107
7150	0.437	11.1	0.150	3.8	0.125	3.2	35	0	67					167108
7160	0.437	11.1	0.160	4.1	0.125	3.2	35	0	67					167109
7170	0.437	11.1	0.170	4.3	0.125	3.2	35	0	67					167110
7180	0.437	11.1	0.180	4.6	0.125	3.2	35	0	67					167115
7190	0.437	11.1	0.190	4.8	0.125	3.2	35	0	67					167111
7200	0.437	11.1	0.200	5.1	0.125	3.2	35	0	67					167112
7250	0.437	11.1	0.250	6.4	0.125	3.2	35	0	67					153811



**CW Style**  
hüvelyk

EN Carbide saw tips for circular saws  
 DE Hartmetallsägezähne für Kreissägen  
 FR Dents de scie pour scies circulaires  
 IT Dentelli per lame circolari  
 HU Vídia fűrészfogak körfűrész tárcsákhoz

	CWD Right	L inch mm	W inch mm	T inch mm	α	β	γ	T07MF-CR
	7165	0.312 7.9	0.165 4.2	0.093 2.4	30	0	60	111711
	7185	0.312 7.9	0.185 4.7	0.093 2.4	30	0	60	111713
	7200	0.312 7.9	0.200 5.1	0.093 2.4	30	0	60	111715
	7215	0.312 7.9	0.215 5.5	0.093 2.4	30	0	60	111717
	7250	0.312 7.9	0.250 6.4	0.093 2.4	30	0	60	111719
	CWD Left	L inch mm	W inch mm	T inch mm	α	β	γ	T07MF-CR
	7165	0.312 7.9	0.165 4.2	0.093 2.4	30	0	60	111712
	7185	0.312 7.9	0.185 4.7	0.093 2.4	30	0	60	111714
	7200	0.312 7.9	0.200 5.1	0.093 2.4	30	0	60	111716
	7215	0.312 7.9	0.215 5.5	0.093 2.4	30	0	60	111718
	7250	0.312 7.9	0.250 6.4	0.093 2.4	30	0	60	111720
	CWG Right	L inch mm	W inch mm	T inch mm	α	β	γ	T07MF-CR
	7230	0.375 9.5	0.230 5.8	0.125 3.2	30	0	60	134882
	7250	0.375 9.5	0.250 6.4	0.125 3.2	30	0	60	132524
	7265	0.375 9.5	0.265 6.7	0.125 3.2	30	0	60	136381
	CWG Left	L inch mm	W inch mm	T inch mm	α	β	γ	T07MF-CR
	7230	0.375 9.5	0.230 5.8	0.125 3.2	30	0	60	134883
	7250	0.375 9.5	0.250 6.4	0.125 3.2	30	0	60	132523
	7265	0.375 9.5	0.265 6.7	0.125 3.2	30	0	60	136382
	CWEV	L inch mm	W inch mm	T inch mm	α	β	γ	T07MF-CR
	7200	0.375 9.5	0.200 5.1	0.093 2.4	30	0	60	119868
								
	CWGV	L inch mm	W inch mm	T inch mm	α	β	γ	T07MF-CR
	7230	0.375 9.5	0.230 5.8	0.125 3.2	30	0	60	115352
								

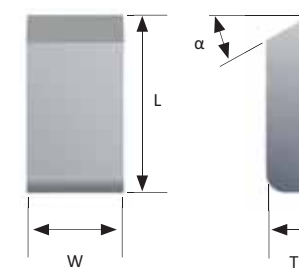
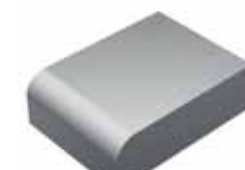

**W Style**  
hüvelyk

EN Carbide saw tips for circular saws  
 DE Hartmetallsägezähne für Kreissägen  
 FR Dents de scie pour scies circulaires  
 IT Dentelli per lame circolari  
 HU Vídia fűrészfogak körfűrész tárcsákhoz

WB	L inch mm	W inch mm	T inch mm	α	β	γ	T10MG	
7100	0.281 7.1	0.100 2.5	0.078 2.0	30	0	0	114162	
7120	0.281 7.1	0.120 3.0	0.078 2.0	30	0	0	114166	
7135	0.281 7.1	0.135 3.4	0.078 2.0	30	0	0	114167	
7150	0.281 7.1	0.150 3.8	0.078 2.0	30	0	0	114170	
7165	0.281 7.1	0.165 4.2	0.078 2.0	30	0	0	114171	
7180	0.281 7.1	0.180 4.6	0.078 2.0	30	0	0	114174	
7185	0.281 7.1	0.185 4.7	0.078 2.0	30	0	0	114175	
7195	0.281 7.1	0.195 5.0	0.078 2.0	30	0	0	114178	
7200	0.281 7.1	0.200 5.1	0.078 2.0	30	0	0	114179	
7250	0.281 7.1	0.250 6.4	0.078 2.0	30	0	0	114183	
WD	L inch mm	W inch mm	T inch mm	α	β	γ	T10MG	
7120	0.312 7.9	0.120 3.0	0.093 2.4	30	0	0	114207	
7135	0.312 7.9	0.135 3.4	0.093 2.4	30	0	0	114214	
7150	0.312 7.9	0.150 3.8	0.093 2.4	30	0	0	114222	
7165	0.312 7.9	0.165 4.2	0.093 2.4	30	0	0	114230	
7185	0.312 7.9	0.185 4.7	0.093 2.4	30	0	0	114239	
7200	0.312 7.9	0.200 5.1	0.093 2.4	30	0	0	114247	
7215	0.312 7.9	0.215 5.5	0.093 2.4	30	0	0	114248	
7230	0.312 7.9	0.230 5.8	0.093 2.4	30	0	0	114255	
7250	0.312 7.9	0.250 6.4	0.093 2.4	30	0	0	114263	
7280	0.312 7.9	0.280 7.1	0.093 2.4	30	0	0	114264	
7312	0.312 7.9	0.312 7.9	0.093 2.4	30	0	0	114271	
WE	L inch mm	W inch mm	T inch mm	α	β	γ	T10MG	
7185	0.375 9.5	0.185 4.7	0.093 2.4	30	0	0	114296	
7200	0.375 9.5	0.200 5.1	0.093 2.4	30	0	0	114297	
7215	0.375 9.5	0.215 5.5	0.093 2.4	30	0	0	114302	
7225	0.375 9.5	0.225 5.7	0.093 2.4	30	0	0	114303	
7250	0.375 9.5	0.250 6.4	0.093 2.4	30	0	0	114309	
7281	0.375 9.5	0.281 7.1	0.093 2.4	30	0	0	114315	
7312	0.375 9.5	0.312 7.9	0.093 2.4	30	0	0	114320	
7350	0.375 9.5	0.350 8.9	0.093 2.4	30	0	0	114321	
7375	0.375 9.5	0.375 9.5	0.093 2.4	30	0	0	114326	
WF	L inch mm	W inch mm	T inch mm	α	β	γ	T07MF-CR	T10MG
7160	0.500 12.7	0.160 4.1	0.125 3.2	35	0	0	152785	114330
7165	0.500 12.7	0.165 4.2	0.125 3.2	35	0	0	152787	114334
7180	0.500 12.7	0.180 4.6	0.125 3.2	35	0	0	152788	114338
7190	0.500 12.7	0.190 4.8	0.125 3.2	35	0	0	152789	114342
7200	0.500 12.7	0.200 5.1	0.125 3.2	35	0	0	152790	114343

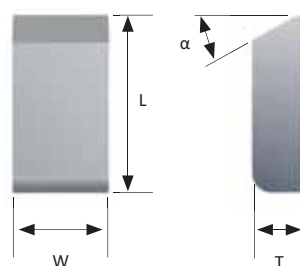
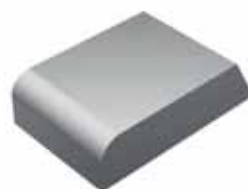

**W Style**  
hüvelyk

EN Carbide saw tips for circular saws  
 DE Hartmetallsägezähne für Kreissägen  
 FR Dents de scie pour scies circulaires  
 IT Dentelli per lame circolari  
 HU Vídia fűrészfogak körfűrész tárcsákhoz

WF	L		W		T		α	β	γ	T07MF-CR	T10MG
	inch	mm	inch	mm	inch	mm					
7230	0.500	12.7	0.230	5.8	0.125	3.2	35	0	0	152791	114351
7240	0.500	12.7	0.240	6.1	0.125	3.2	35	0	0	152792	114354
7250	0.500	12.7	0.250	6.4	0.125	3.2	35	0	0	152793	114355
7275	0.500	12.7	0.275	7.0	0.125	3.2	35	0	0	152794	114362
7280	0.500	12.7	0.280	7.1	0.125	3.2	35	0	0	152795	114363
7300	0.500	12.7	0.300	7.6	0.125	3.2	35	0	0	152796	114366
7312	0.500	12.7	0.312	7.9	0.125	3.2	35	0	0	152797	114367
7350	0.500	12.7	0.350	8.9	0.125	3.2	35	0	0	152798	114370
7375	0.500	12.7	0.375	9.5	0.125	3.2	35	0	0	152799	114371
7400	0.500	12.7	0.400	10.2	0.125	3.2	35	0	0	152800	114374
7437	0.500	12.7	0.437	11.1	0.125	3.2	35	0	0	152801	114375
7500	0.500	12.7	0.500	12.7	0.125	3.2	35	0	0	152802	114378
7625	0.500	12.7	0.625	15.9	0.125	3.2	35	0	0	152803	114379

WG	L		W		T		α	β	γ	T10MG
	inch	mm	inch	mm	inch	mm				
7150	0.375	9.5	0.150	3.8	0.125	3.2	30	0	0	138350
7165	0.375	9.5	0.165	4.2	0.125	3.2	30	0	0	138351
7185	0.375	9.5	0.185	4.7	0.125	3.2	30	0	0	138352
7200	0.375	9.5	0.200	5.1	0.125	3.2	30	0	0	115371
7215	0.375	9.5	0.215	5.5	0.125	3.2	30	0	0	115372
7230	0.375	9.5	0.230	5.8	0.125	3.2	30	0	0	115337
7250	0.375	9.5	0.250	6.4	0.125	3.2	30	0	0	115373
7265	0.375	9.5	0.265	6.7	0.125	3.2	30	0	0	138353
7280	0.375	9.5	0.280	7.1	0.125	3.2	30	0	0	128767
7312	0.375	9.5	0.312	7.9	0.125	3.2	30	0	0	115374
7335	0.375	9.5	0.335	8.5	0.125	3.2	30	0	0	140921
7350	0.375	9.5	0.350	8.9	0.125	3.2	30	0	0	138354
7375	0.375	9.5	0.375	9.5	0.125	3.2	30	0	0	140922
7400	0.375	9.5	0.400	10.2	0.125	3.2	30	0	0	140924
7500	0.375	9.5	0.500	12.7	0.125	3.2	30	0	0	138447

WQ	L		W		T		α	β	γ	T10MG
	inch	mm	inch	mm	inch	mm				
7200	0.375	9.5	0.200	5.1	0.156	4.0	30	0	0	114400
7265	0.375	9.5	0.265	6.7	0.156	4.0	30	0	0	114401
7300	0.375	9.5	0.300	7.6	0.156	4.0	30	0	0	114402
7335	0.375	9.5	0.335	8.5	0.156	4.0	30	0	0	114403
7400	0.375	9.5	0.400	10.2	0.156	4.0	30	0	0	114404
7460	0.375	9.5	0.460	11.7	0.156	4.0	30	0	0	114405
7500	0.375	9.5	0.500	12.7	0.156	4.0	30	0	0	114406
7530	0.375	9.5	0.530	13.5	0.156	4.0	30	0	0	140931
7625	0.375	9.5	0.625	15.9	0.156	4.0	30	0	0	114407
7640	0.375	9.5	0.640	16.3	0.156	4.0	30	0	0	140932
7765	0.375	9.5	0.765	19.4	0.156	4.0	30	0	0	140933

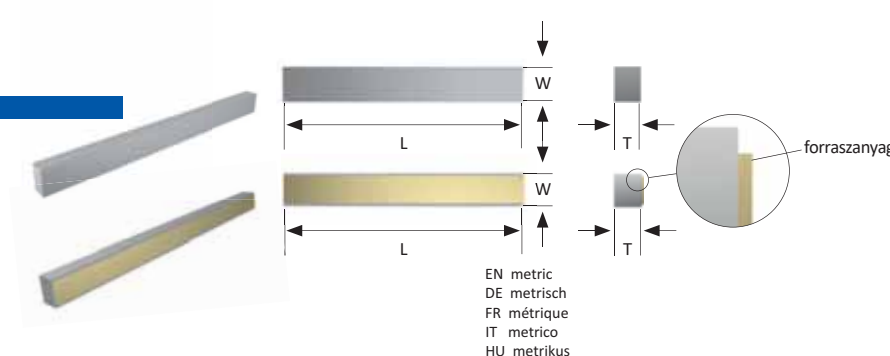

EN Strobe blanks for circular saws  
 DE Wischerblätter für Kreissägen  
 FR Racleurs pour scies circulaires  
 IT Barrette per rasanti di lame circolari  
 HU Tisztítófogak körfűrész tárcsákhoz

L	W	T	T07MF-W
mm	mm	mm	
25	2	2	111033
25	2.5	2	113529
25	3	2	109812
30	3	2	043520
35	3	2	113533
40	3	2	043522
30	3.3	2	049602
35	3.3	2	113544
40	3.3	2	113546
310	3.3	2	113555
30	3.5	2	043514
40	3.5	2	043516
45	3.5	2	113557
50	3.5	2	109811
30	3.7	2	036174
40	3.7	2	113565
50	3.7	2	113566
20	4	2	111032
30	4	2	043521
35	4	2	113572
40	4	2	043523
45	4	2	113574
50	4	2	111046
55	4	2	113576
60	4	2	111049
50	4.2	2	036811
60	4.2	2	113582
310	4.2	2	113584

L	W	T	T07MF-W
mm	mm	mm	
30	4.5	2	111037
40	4.5	2	111041
45	4.5	2	111045
50	4.5	2	111047
55	4.5	2	113585
60	4.5	2	111050
310	4.5	2	113592
40	5	2	043525
45	5	2	113594
50	5	2	113595
55	5	2	113596
60	5	2	111051
65	5	2	113597
30	5.5	2	111039
40	5.5	2	111042
50	5.5	2	111048
60	5.5	2	113599
65	5.5	2	113600
310	5.5	2	113773
60	6	2	113602
60	6.2	2	111053
310	6.5	2	113605



EN Strobe blanks for circular saws  
 DE Wischerblätter für Kreissägen  
 FR Racleurs pour scies circulaires  
 IT Barrette per rasanti di lame circolari  
 HU Tisztítófogak körfűrész tárcsákhoz

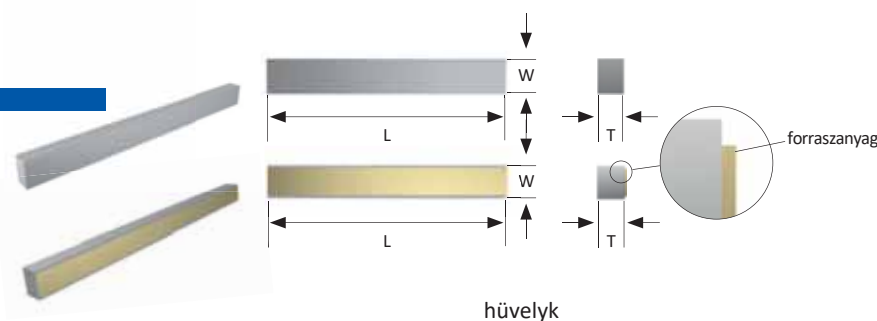

ST	L inch	mm	W inch	mm	T inch	mm	T12M-CR
ST1130	1.000	25.4	0.130	3.3	0.125	3.2	113530
ST1140	1.000	25.4	0.140	3.6	0.125	3.2	113534
ST1150	1.000	25.4	0.150	3.8	0.125	3.2	113535
ST1160	1.000	25.4	0.160	4.1	0.125	3.2	113536
ST1170	1.000	25.4	0.170	4.3	0.125	3.2	113537
ST1180	1.000	25.4	0.180	4.6	0.125	3.2	113538
ST1250	1.000	25.4	0.250	6.4	0.125	3.2	113550
ST1260	1.000	25.4	0.260	6.6	0.125	3.2	113552

ST	L inch	mm	W inch	mm	T inch	mm	T12M-CR
ST2150	1.250	31.8	0.150	3.8	0.125	3.2	113561
ST2170	1.250	31.8	0.170	4.3	0.125	3.2	113563
ST2190	1.250	31.8	0.190	4.8	0.125	3.2	113571
ST2240	1.250	31.8	0.240	6.1	0.125	3.2	113581
ST2250	1.250	31.8	0.250	6.4	0.125	3.2	113586
ST2260	1.250	31.8	0.260	6.6	0.125	3.2	113587

EN Brazing alloys and fluxes  
 DE Lot und Flussmittel  
 FR Alliages et flux de brasage  
 IT Leghe brasanti e disossidanti  
 HU Forrasanyagok és folyatók



EN AutoFlux - brazing flux paste for automatic dispensing  
 DE AutoFlux - Hartlot Flussmittel-Paste für Maschinendosierung  
 FR AutoFlux - flux de brasage en pâte pour mise en oeuvre en automatique  
 IT AutoFlux - disossidante in pasta per brasatura adatto per la distribuzione automatica  
 HU AutoFlux -keményforrasztó folyatóanyag gépi adagolóhoz

Termék	Súly kg
115300	1.5

EN ManuFlux - brazing flux paste for manual applications  
 DE ManuFlux - Hartlot Flussmittel-Paste für den Auftrag von Hand  
 FR ManuFlux - flux de brasage en pâte pour utilisation manuelle  
 IT ManuFlux - disossidante in pasta per brasatura per applicazione manuale  
 HU ManuFlux -keményforrasztó folyatóanyag kézi adagolóhoz

Termék	Súly kg
115301	1.0

EN Brazing alloys and fluxes  
 DE Lot und Flussmittel  
 FR Alliages et flux de brasage  
 IT Leghe brasanti e disossidanti  
 HU Forrasanyagok és folyatók



EN TriMet - sandwich brazing alloy strip, on spool  
 DE TriMet - Schichtlot, auf Spule  
 FR TriMet - alliage de brasage „sandwich“ en bande, sur bobine  
 IT TriMet - lega brasante nastro trimetallico, in bobina  
 HU TriMet - szendvics forrasanyag szalag, feltekercselve

Termék	W mm	T mm	Súly kg	Jellemzők
122449	2.0	0.3	1.0 - 1.5	EN Trimetal shim DE Schichtlot FR Trimétal IT Trimetallici HU Háromfémű réz közepű szalag
123911	2.2	0.3	1.0 - 1.5	
122450	2.5	0.3	1.0 - 1.5	
122451	3.0	0.3	1.0 - 1.5	
122452	3.2	0.3	1.0 - 2.0	
122453	3.5	0.3	1.5 - 2.0	
122454	4.0	0.3	1.5 - 2.0	
133282	4.5	0.3	1.5 - 2.0	
130813	5.0	0.3	1.5 - 2.0	
133763	5.5	0.3	1.5 - 2.0	
157267	6.0	0.3	1.5 - 2.0	HU Háromfémű réz közepű szalag
128887	7.0	0.3	1.5 - 2.0	
162305	8.0	0.3	1.5 - 2.0	
123653	25.0	0.3	1.0 - 1.5	
123897	8.0	0.4		
167158	25.0	0.4		







EN TriMet - sandwich brazing alloy strip for special applications, in coils  
 DE TriMet - Lot für Sonderanwendungen, im Bunde  
 FR TriMet - alliage de brasage „sandwich“ pour applications spéciales, en bande  
 IT TriMet - lega brasante nastro trimetallico per applicazioni speciali, in bobina  
 HU TriMet - speciális felhasználású szendvics forrasanyag szalag, tekercsben

Termék	W mm	T mm	Súly kg
122456	40	0.8	1.0
122457	50	0.8	1.0
122458	60	0.8	1.0
122459	70	0.8	1.0



- EN Carbide for brazed tools
- DE Hartmetall für gelötete Fräser
- FR Plaquettes en carbure à braser
- IT Metallo duro per frese saldobrasate
- HU Vídiák forrasztottlapkás szerszámokhoz

EN Carbide for brazed tools  
 DE Hartmetall für gelötete Fräser  
 FR Plaquettes en carbure à braser  
 IT Metallo duro per frese saldobrasat  
 HU Védiák forrasztottlapkás szerszámokhoz

	<p>EN Carbide strips for brazed cutters            DE Hartmetallplatten zur Fräserbestückung            FR Plaquettes en carbure à braser            IT Placchette in metallo duro per frese            HU Védialapák forrasztottlapkás marókhöz</p>	<p>metric            metrisch            métrique            metrico            metrikus</p>	92 - 96
	<p>EN STB strips for brazed cutters            DE Hartmetallplatten zur Fräserbestückung            FR Plaquettes en carbure à braser            IT Placchette in metallo duro per frese            HU Védialapák forrasztottlapkás marókhöz</p>	<p>hüvelyk</p>	97
	<p>EN Preforms for brazed cutters            DE Formplatten zum Löten            FR Plaquettes en carbure à braser            IT Placchette per frese saldobrasate            HU Profillapák forrasztottlapkás marókhöz</p>		98
	<p>EN Carbide tips for router bits            DE HM-Rohlinge für Oberfräser            FR Ébauches pour mèches à défoncer            IT Placchette sagomate per punte            HU Védia nyerslapkák felsőmarókhöz</p>		99
	<p>EN Drill bit tips            DE Zylinderkopfbohrerplatten            FR Mèches à façonner            IT Punte per cerniere            HU Pánthelyfúrók</p>		100 - 101
	<p>EN Strips for T.C.T. knives            DE Streifen für HW-bestückte Messer            FR Plaquettes pour fabriquer des fers rapportées carbure            IT Placchette per fabbricare coltelli riportati HW            HU Nyerslapka vídiabetés késekhez</p>		102
	<p>EN Tips for multicut planers            DE Zähne für Vielzahnfräser            FR Dents spéciales            IT Dentelli per frese multitaglienti            HU Fogak sokfogú marókhöz</p>		102



EN Carbide for brazed tools - Carbide grades and their applications  
 DE Hartmetall für gelötete Fräser - Hartmetallsorten und ihre Anwendungen  
 FR Plaquettes en carbure à braser - Les nuances de carbures et leurs applications  
 IT Metallo duro per frese saldobrasate - I tipi di metallo duro e le loro applicazioni  
 HU Vídia forrasztottlapkás szerszámokhoz - Vídia kategóriák és felhasználásuk

EN	TIGRA grade	ISO	USA	Hardness	Toughness	Bending strength	Plastics	HDF	MDF	Chipboard	Hardwood	Softwood	Main usage
DE	TIGRA - Sorte	ISO	USA	Härte	Zähigkeit	Biegebruchfestigkeit	Plastik	HDF	MDF	Spanplatte	Hartholz	Weichholz	Hauptverwendung
FR	Nuance TIGRA	ISO	USA	Dureté	Ténacité	Résistance à la flexion	Plastiques	HDF	MDF	Panneaux de particule	Bois dur	Bois tendre	Usage principal
IT	Tipo TIGRA	ISO	Stati uniti	Durezza	Tenacità	Resistenza flessionale	Plastica	HDF	MDF	Truciolare	Legno duro	Legno tenero	Usi principali
HU	TIGRA kategória	ISO	USA	Keménység	Szívósság	Hajlítószilárdság	Műanyag	HDF	MDF	Forgácslap	Keményfa	Puhafa	Fő alkalmazási terület
	T03F-CR	K01	C4+	↑	↖	↓	✓	✓	✓	○	○	☒	EN Board materials DE Plattenmaterial FR Matériaux de panneaux IT Pannelli HU Táblás anyagok
	T04F-CR	K05	C4	↖	→	↖	✓	○	✓	✓	✓	○	EN Abrasive hard woods DE Abrasive Harthölzer FR Bois durs abrasifs IT Legni duri abrasivi HU Koptató keményfák
	T07MF-CR UNIVERSAL	K20 - K30	C2 - C3	↖	↑	↖	○	○	○	✓	✓	✓	EN Universal grade DE Universelle Sorte FR Nuance universelle IT Tipo universale HU Univerzális felhasználás
	T07MF-W	K20 - K30	C2 - C3	→	↖	↖	○	○	○	○	✓	✓	EN Economic universal grade DE Preiswerte Universalsorte FR Nuance universelle peu coûteuses IT Tipo universale a basso costo HU Gazdaságos univerzális felhasználás
	T10MG	K10 - K40	C3+	→	↖	↑	☒	☒	☒	○	✓	✓	EN Wood DE Holz FR Bois IT Legno HU Faanyag
	TL15*	K10 - K40	C2+	↖	↑	↑	☒	☒	☒	☒	✓	✓	EN Wood, higher clearance angles DE Holz, größere Freiwinkel FR Bois, plus grands angles de dépouille IT Legno, angoli di spoglia grandi HU Fa, igen nagy vágószögek

✓ kiváló teljesítőképesség  
 ✓ nagyon jó teljesítmény  
 ○ elfogadható  
 ☒ - nem alkalmas

CR = Co + Ni + Cr = corrosion resistant - korrosionsbeständig - anti-corrosif - inossidabile - korrózióálló

\* Special binder - Spezialbinder - Liant spécial - Legante speciale - Speciális kötőanyag

EN For technical data, please refer to the pages 4-5.  
 DE Die technischen Daten entnehmen Sie bitte den Seiten 4-5.  
 FR Pour les données techniques, veuillez voir aux pages 4-5.

IT Per i dati tecnici, fare riferimento alle pagine 4-5.  
 HU A műszaki adatokat a 4-5. oldalon találja.



EN Carbide strips for brazed cutters  
 DE Hartmetallplatten zur Fräsebestückung  
 FR Plaquettes en carbure à braser  
 IT Placchette in metallo duro per frese  
 HU Vídialapkák forrasztottlapkás marókhöz

T = 2-4 mm

L mm	W mm	T mm	T04F-CR	T07MF-CR	T10MG	T07MF-W
310	4	2		131017		
310	5	2		131018	100549	
310	6	2	100309	131019	029130	
310	8	2	101107	131020	029131	
310	10	2	100710	131021	029132	
310	12	2	100709	131022	029133	
310	14	2	101637	131023	029136	
310	15	2	108730	131024	054311	
310	16	2	108731	131025	029138	
310	18	2	108732	131026	029139	
310	20	2	055678	131027	029140	
310	22	2	108737	131028	038192	
310	25	2	055679	131029	029141	
310	30	2	055680	131030	031186	
310	5	3		131031		
310	6	3		131032	024511	
310	8	3	100311	131033	024515	
310	10	3	101638	131034	024519	140203
310	12	3	100619	131036	024523	
310	13	3	121841	131038	041839	
310	14	3	108738	131040	024527	
310	15	3	100312	131042	041072	
310	16	3	105249	131044	024531	140207
310	18	3	108739	131046	024535	
310	20	3	100313	131048	024539	
310	25	3	108740	131050	024543	
310	30	3	108741	131053	024547	
310	4	4			110302	
310	8	4	100626	131055	024566	147956
310	10	4	101106	131057	024570	147509
310	12	4	100625	131060	024574	144792
310	14	4	102820	131062	024578	140212
310	15	4	100315	131068	103213	
310	16	4	100621	131071	024582	147600
310	18	4	100316	131074	024586	147601
310	20	4	101729	131077	024590	147602
310	22	4	100317	131081	047082	
310	25	4	100318	131084	024594	140219
310	28	4	106131	131086	103214	
310	30	4	105525	131088	024598	
310	35	4	108742	131091	051786	



EN Carbide strips for brazed cutters  
 DE Hartmetallplatten zur Fräsebestückung  
 FR Plaquettes en carbure à braser  
 IT Placchette in metallo duro per frese  
 HU Vídialapkák forrasztottlapkás marókhöz

T = 5-6 mm

L mm	W mm	T mm	T04F-CR	T07MF-CR	T10MG	T07MF-W
310	5	5			110303	
310	8	5		131101	024627	
310	10	5	108768	131102	024631	
310	12	5	100319	131103	024635	140225
310	14	5	102229	131106	024639	
310	15	5	100627	131109	039582	
310	16	5	108744	131112	024643	
310	18	5	100321	131113	024647	
310	20	5	100322	131119	024651	
310	25	5	100323	131121	024655	
310	30	5	108745	131123	024659	
310	35	5	108746	131127	051788	
170	40	5	108747	131130	050106	
310	10	6			024680	
310	16	6		131135	024692	
310	20	6		131137	024700	
310	25	6		131140	024704	
310	30	6		131142	024708	



EN Carbide strips for brazed cutters  
 DE Hartmetallplatten zur Fräserbestückung  
 FR Plaquettes en carbure à braser  
 IT Placchette in metallo duro per frese  
 HU Vídialapkák forrasztottlapkás marókhhoz

L mm	W mm	T mm	T04F-CR	T07MF-CR	T10MG
310	8	3	108748	131035	024725
310	10	3	108749	131037	024729
310	12	3	108750	131039	024733
310	14	3	108752	131041	024737
310	15	3	108753	131043	041080
310	16	3	108754	131045	024741
310	18	3	108755	131047	024745
310	20	3	108756	131049	024749
310	25	3	108757	131051	024753
310	30	3	108758	131052	024757
310	8	4	108759	131054	024765
310	10	4	108760	131056	024769
310	12	4	108761	131058	024773
310	14	4	108762	131059	024777
310	15	4	108763	131061	041081
310	16	4	108703	131063	024781
310	18	4	108764	131064	024785
310	20	4	102884	131065	024789
310	22	4	102885	131066	041082
310	25	4	102886	131067	024793
310	28	4	102887	131069	041083
310	30	4	108765	131070	024797
310	35	4	108766	131072	041084
310	8	5	108767	131073	024805
310	10	5	108769	131075	024809
310	12	5	108771	131076	024813
310	14	5	108772	131078	024817
310	15	5	108773	131080	103218
310	16	5	108704	131082	024821
310	18	5	108774	131083	024825
310	20	5	108705	131085	024829
310	25	5	108706	131087	024833
310	30	5	108707	131089	024837
310	35	5	108775	131090	051793
170	40	5	115072	131092	029264
310	10	6		131093	024849
310	12	6		131094	024853
310	16	6		131096	024861
310	20	6		131097	024869
310	25	6		131098	024873
310	30	6		131099	024877



EN Carbide strips for brazed cutters  
 DE Hartmetallplatten zur Fräserbestückung  
 FR Plaquettes en carbure à braser  
 IT Placchette in metallo duro per frese  
 HU Vídialapkák forrasztottlapkás marókhhoz

L mm	W mm	T mm	T04F-CR	T07MF-CR	T10MG
310	8	3	108777	131104	024885
310	10	3	108778	131105	024889
310	12	3	108779	131107	024893
310	14	3	108780	131108	024897
310	15	3	108781	131110	103222
310	16	3	108782	131111	024901
310	18	3	108783	131114	024905
310	20	3	108784	131115	024909
310	25	3	108785	131117	024913
310	30	3	108786	131118	024917
310	8	4	100629	131120	024931
310	10	4	108787	131122	024935
310	12	4	103853	131124	024939
310	14	4	102230	131125	024943
310	15	4	108788	131128	050690
310	16	4	103854	131129	024947
310	18	4	108789	131131	024951
310	20	4	108790	131132	024955
310	22	4	108791	131134	103223
310	25	4	108792	131136	024959
310	28	4	108793	131138	101527
310	30	4	108794	131139	024963
310	35	4	108797	131141	051797
310	8	5	108798	131151	024978
310	10	5	054402	131153	024982
310	12	5	055663	131154	024986
310	14	5	102563	131156	024990
310	15	5	100628	131158	035897
310	16	5	106180	131159	024994
310	18	5	004371	131161	024998
310	20	5	054231	131163	025002
310	25	5	054439	131165	025006
310	30	5	054677	131166	025010
310	35	5	056072	131168	051799
170	40	5	053297	131170	039094
310	10	6	054403	131171	025023
310	12	6	004372	131173	025027
310	16	6	108799	131174	025035
310	20	6	054323	131176	025043
310	25	6	108800	131177	025047
310	30	6	004375	131179	025051





EN Carbide strips for brazed cutters  
 DE Hartmetallplatten zur Fräserbestückung  
 FR Plaquettes en carbure à braser  
 IT Placchette in metallo duro per frese  
 HU Vídialapkák forrasztottlapkás marókhhoz

**ÚJ!**

675 mm

	L mm	W mm	T mm	T07MF-W
	675	8	3	165519
	675	10	3	165520
	675	12	3	165521
	675	14	3	165522
	675	16	3	165523
	675	18	3	165524
	675	20	3	165525
	675	10	4	164593
	675	12	4	165526
	675	14	4	165527
	675	16	4	165528

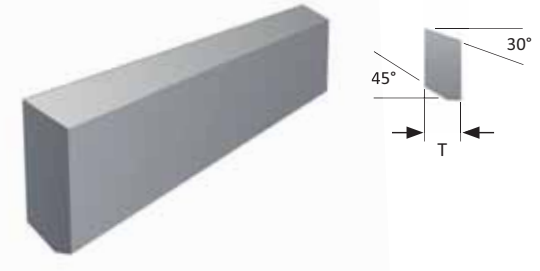
	L mm	W mm	T mm	T07MF-W
	675	8	3	165529
	675	10	3	165530
	675	12	3	165531
	675	14	3	165532
	675	16	3	165533
	675	10	4	165534
	675	12	4	165535
	675	16	4	165536
	675	20	4	165537
	675	16	5	165538
	675	20	5	165539



EN STB strips for brazed cutters  
 DE Hartmetallplatten zur Fräserbestückung  
 FR Plaquettes en carbure à braser  
 IT Placchette in metallo duro per frese  
 HU Vídialapkák forrasztottlapkás marókhhoz

USA típus -hüvelyk

Típus	L inch	W inch	T inch	T07MF-CR	T10MG
DSTB 312	12 1/4	3/8	3/32	131322	128447
DSTB 316	12 1/4	1/2	3/32	131323	128449
DSTB 320	12 1/4	5/8	3/32	131324	128451
DSTB 324	12 1/4	3/4	3/32	131327	128453
DSTB 412	12 1/4	3/8	1/8	131328	128455
DSTB 416	12 1/4	1/2	1/8	131329	128457
DSTB 420	12 1/4	5/8	1/8	131330	128459
DSTB 424	12 1/4	3/4	1/8	131331	128461
DSTB 428	12 1/4	7/8	1/8	131332	128463
DSTB 432	12 1/4	1	1/8	131333	128465
DSTB 440	12 1/4	1 1/4	1/8		139794
DSTB 512	12 1/4	3/8	5/32	137611	142726
DSTB 516	12 1/4	1/2	5/32	131334	128467
DSTB 520	12 1/4	5/8	5/32	137612	133132
DSTB 524	12 1/4	3/4	5/32	137613	133133
DSTB 532	12 1/4	1	5/32	137614	133134
DSTB 540	12 1/4	1 1/4	5/32	142728	133135



- EN Preforms for brazed cutters
- DE Formplatten zum Löten
- FR Plaquettes en carbure à braser
- IT Placchette per frese saldobrasate
- HU Előprofilok forrasztás

EN Using preformed tips for your brazed cutters you will save the expensive roughing time and grinding wheel cost. TIGRA can supply almost any kind of preformed tip according to the customer's drawing or DXF file. Small quantities for urgent special tools can be delivered by our quick delivery service within one week.

DE Durch die Verwendung vorgeformter Hartmetallplatten sparen Sie teure Schruppzeiten und Kosten für die Schleifscheiben. TIGRA liefert nahezu jede vorgeformte Platte nach Kundenzeichnung oder DXF-Datei. Kleinserien für eilige Sonderwerkzeuge liefert unser Schnelldienst innerhalb von einer Woche.

FR Grâce à l'utilisation de plaquettes en carbure préprofilées, plus besoin de coûteuses opérations de dégrossissage ni des frais élevés pour les meules. TIGRA peut fournir pratiquement n'importe quelle plaquette préprofilée d'après le dessin du client ou un fichier DXF. Notre services d'urgence livre de petites séries pour les outils spéciaux urgents en une semaine.

IT Con l'uso delle placchette presagomate risparmierete non solo la sgrossatura bensì anche i costi delle mole. TIGRA può fornire quasi ogni tipo di placchette presagomate a seconda delle Vostre richieste ed esigenze (documenti DXF; disegni). Per ordini urgenti di piccole quantità riguardanti utensili particolari siamo in grado di fornirvi la merce nell'arco di una settimana.

HU Előre gyártott profilapokkal drága nagyolási időt és köszörűkorong költséget takarít meg. A TIGRA szinte minden ügyfélrajz vagy DXF-fájl szerinti előregyártott lapkát tud szállítani. Sürgős egyedi szerszámokhoz kis sorozatot gyorsszolgálatunk egy héten belül szállít.

EN With chamfers in the profile and/or at the bottom.  
DE Mit Fasen im Profil und/oder an der Anschlagkante.  
FR Avec des biseaux dans le profil et/ou au bord de butée.

IT Con smussi nel profilo e/o nello spigolo di battuta.  
HU Leélezés a profilban és/vagy lent.

- EN Profile group 1
- DE Profilgruppe 1
- FR Groupe de profil 1
- IT Gruppo profilo 1
- HU Profilsorozat: 1



- EN Profile group 2
- DE Profilgruppe 2
- FR Groupe de profil 2
- IT Gruppo profilo 2
- HU Profilsorozat: 2



- EN Profile group 3
- DE Profilgruppe 3
- FR Groupe de profil 3
- IT Gruppo profilo 3
- HU Profilsorozat: 3



EN Without any chamfers and therefore less expensive!  
DE Keinerlei Fasen. Der Preis dafür ist deutlich günstiger!  
FR Sans des biseaux. Le prix de ce modèle est de ce fait bien plus avantageux!

HU Mindenféle leélezés nélkül, ezért sokkal olcsóbb!  
ES Ningun bisel. El precio de este modelo sera muy ventajoso para vd

sl

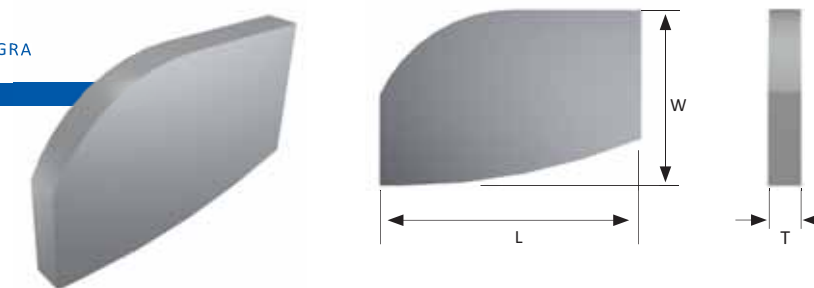

- EN Preforms for router bits
- DE Platten für Oberfräser
- FR Plaquettes pour défonceuse
- IT Placchette sagomate per punte
- HU Előprofilapok felsőmaróhoz

EN Carbide tips for router bits are available preformed in almost any sizes or executions, as per customer's drawing or DXF file, also for small quantities. Your production cost for router bits will be reduced by saving the cost for cutting, wire cutting, roughing and diamond wheels. Small quantities for urgent special tools are supplied from our quick delivery service within only one week.

DE Hartmetallplatten für Oberfräser sind vorgeformt in fast allen Größen und Ausführungen nach Kundenzeichnung oder DXF-Datei lieferbar, auch für Kleinserien. So sparen Sie auch bei der Herstellung von Oberfräsern die Kosten für das Trennen, Drahtschneiden oder Schruppen sowie Kosten für Schleifscheiben. Kleinserien für eilige Sonderwerkzeuge liefert unser Schnelldienst innerhalb von einer Woche.

FR Les plaquettes en carbure pour défonceuse peuvent être livrées préfaçonnées dans pratiquement toutes les tailles et exécutions d'après le dessin du client ou un fichier DXF, même en petites séries. Vous économisez ainsi les frais de tronçonnage, de meules abrasive même lors de la fabrication d'outil pour défonceuses. Notre service d'urgence livre de petites séries pour les outils spéciaux urgents en une semaine.

IT Le placchette sagomate per punte sono disponibili in quasi ogni misura secondo disegno o documento DXF, anche in quantità minime. Risparmiate i costi di tagli, sgrossatura e delle mole per la produzione delle punte. Per ordini urgenti di piccole quantità riguardanti utensili particolari siamo in grado di fornirvi la merce in una settimana.

HU Vídialapok felsőmaróhoz előformázottan szinte minden méretben és kivitelben ügyfélrajz vagy DXF-fájl szerint szállíthatók, kis sorozatban is. Így felsőmaró gyártásánál megtakarítja a darabolás, szikraforgácsolás vagy nagyolás költségeit, valamint köszörűkorong költséget. Sürgős egyedi szerszámokhoz kis sorozatot gyorsszolgálatunk egy héten belül szállít.



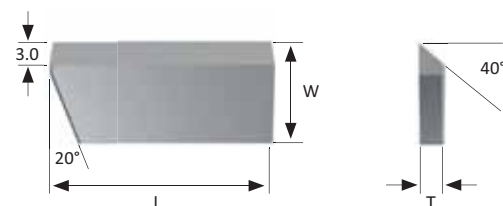
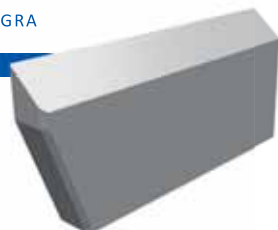

EN right  
DE rechts  
FR droite  
IT destra  
HU jobbos

EN Drill bit tips  
DE Zylinderkopfbohrerplatten  
FR Mèches à façonner  
IT Punte per cerniere  
HU Pánthelyfúrók

d	L mm	W mm	T mm	T07MF-CR
15.0	6.5	8.5	2.5	032676
16.0	7.0	10.5	2.5	032677
18.0	8.0	10.5	2.5	032678
20.0	9.0	10.5	2.5	032679
22.0	10.0	10.5	2.5	032680
23.0	10.5	10.5	2.5	032681
24.0	11.0	10.5	2.5	032682
25.0	11.5	10.5	2.5	032683
26.0	12.0	10.5	2.5	032684
28.0	13.0	10.5	2.5	032685
30.0	14.0	10.5	2.5	032686
32.0	15.0	10.5	2.5	032687
34.0	16.0	10.5	2.5	032688
35.0	16.5	10.5	2.5	032689
38.0	18.0	10.5	2.5	032690
40.0	19.0	10.5	2.5	032691
45.0	21.5	10.5	2.5	032692
50.0	24.0	10.5	2.5	032693
55.0	26.5	10.5	2.5	032694
60.0	29.0	10.5	2.5	032695

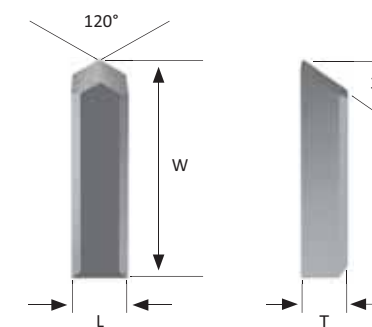
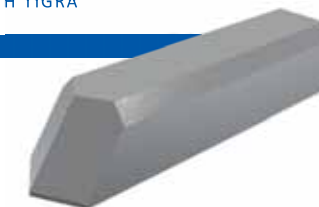

EN Drill bit tips  
DE Zylinderkopfbohrerplatten  
FR Mèches à façonner  
IT Punte per cerniere  
HU Pánthelyfúrók

	d	L mm	W mm	T mm	T07MF-CR	T10MG
		3.0	12.0	2.5	032702	
		4.0	13.0	2.5	032703	
	3.0	13.0				159026



- EN Strips for T.C.T. knives  
 DE Streifen für HW-bestückte Messer  
 FR Plaquettes pour fabriquer des fers rapportés carbure  
 IT Placchette per fabbricare coltelli riportati HW  
 HU Nyerslapka vídiabetétes késekhez

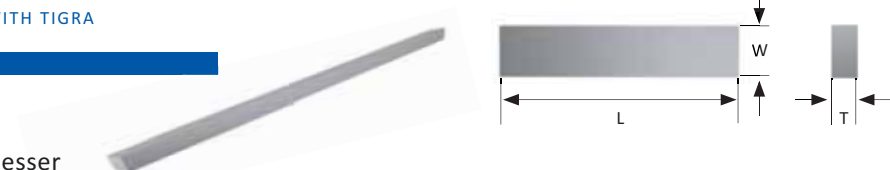

L mm	W mm	T mm	T10MF
1052	11.2	1.3	151256

- EN Tips for multicut planers  
 DE Zähne für Vielzahnfräser  
 FR Dents spéciales  
 IT Dentelli per frese multitaglienti  
 HU Fogak sokfogú gyalufejekhez

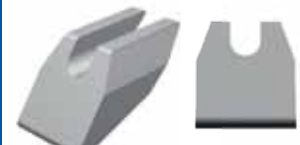
	L mm	W mm	T mm	T10MG
	12.8	6.2	5.3	029090
	12.8	8.2	5.3	114884
	12.8	6.2	5.3	112940

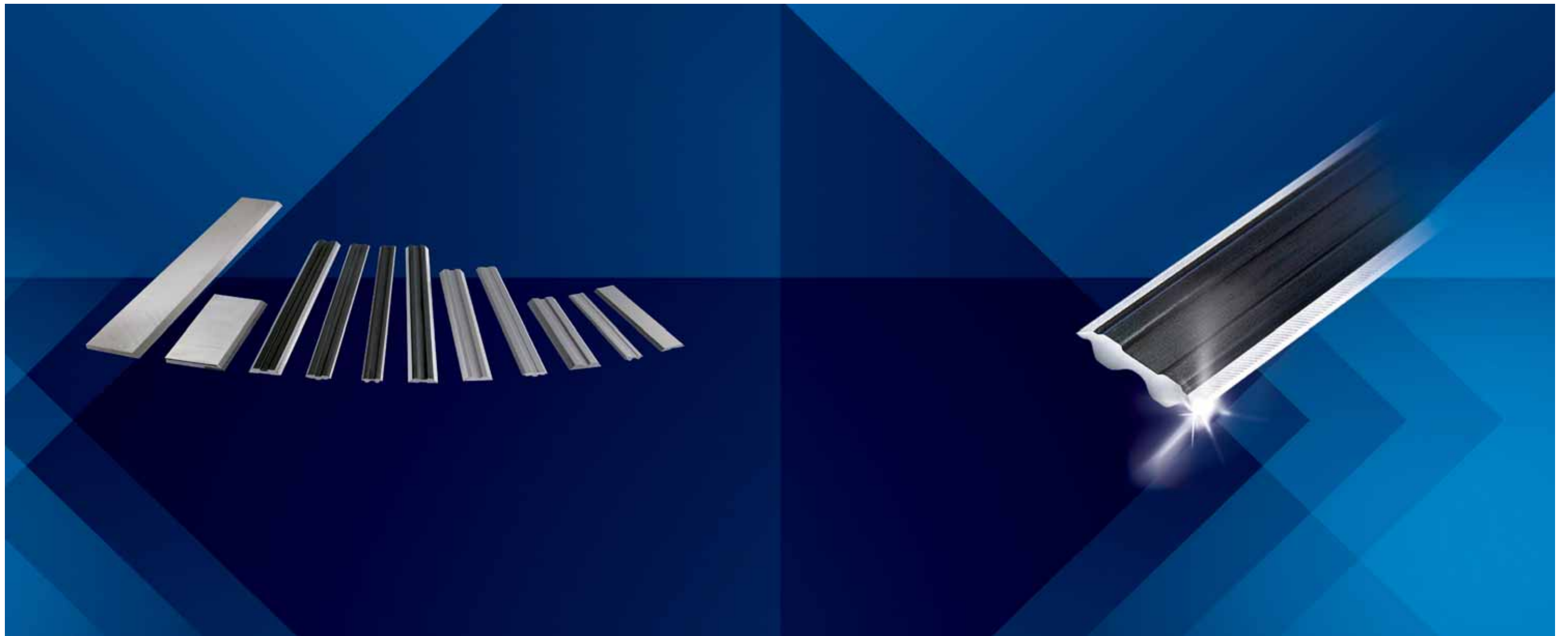

EN Planer knives  
DE Hobelmesser  
FR Couteaux à raboter  
IT Coltelli da pialla  
HU Gyalukések

EN Planer knives  
 DE Hobelmesser  
 FR Couteaux à raboter  
 IT Coltelli da pialla  
 HU Gyalukések

	EN Reversible knives for portable planers DE Wendeschneidplatten für Handhobel FR Plaquettes pour rabots électro portatifs IT Coltelli per pialatrici portatili HU Megfordítható kések hordozható gyalugépekhez	112
	EN Planer knives for system Tersa DE Hobelmesser für System Tersa FR Couteaux à raboter pour système Tersa IT Coltelli da pialla per sistema Tersa HU Tersa rendszerű gyalukések	113 - 114
	EN Planer knives for system Centrolock DE Hobelmesser für System Centrolock FR Couteaux à raboter pour système Centrolock IT Coltelli da pialla per sistema Centrolock HU Centrolock rendszerű gyalukések	115
	EN Planer knives for system Terminus DE Hobelmesser für System Terminus FR Couteaux à raboter pour système Terminus IT Coltelli da pialla per sistema Terminus HU Terminus rendszerű gyalukések	116
	EN Planer knives for system Centrofix / Centrostar / Quickfix DE Hobelmesser für System Centrofix / Centrostar / Quickfix FR Couteaux à raboter pour système Centrofix / Centrostar / Quickfix IT Coltelli da pialla per sistema Centrofix / Centrostar / Quickfix HU Centrofix / Centrostar / Quickfix rendszerű gyalukések	117
	EN Planer knives for system Variplan DE Hobelmesser für System Variplan FR Couteaux à raboter pour système Variplan IT Coltelli da pialla per sistema Variplan HU Variplan rendszerű gyalukések	118
	EN Planer knives for system Sinus DE Hobelmesser für System Sinus FR Couteaux à raboter pour système Sinus IT Coltelli da pialla per sistema Sinus HU Sinus rendszerű gyalukések	119
	EN Planer knives for system Enshin DE Hobelmesser für System Enshin FR Couteaux à raboter pour système Enshin IT Coltelli da pialla per sistema Enshin HU Enshin rendszerű gyalukések	120 - 121
	EN Planer knives for system Bulldozer DE Hobelmesser für System Bulldozer FR Couteaux à raboter pour système Bulldozer IT Coltelli da pialla per sistema Bulldozer HU Bulldozer rendszerű gyalukések	122
	EN Planer knives for system Barke / Brück / ESTA DE Hobelmesser für System Barke / Brück / ESTA FR Couteaux à raboter pour système Barke / Brück / ESTA IT Coltelli da pialla per sistema Barke / Brück / ESTA HU Barke / Brück / ESTA rendszerű gyalukések	123
	EN HSS / Matrix planer knives DE HSS / Matrix-Hobelmesser FR Fers de raboteuse HSS / Matrix IT Coltelli da pialla HSS / Matrix HU HSS / Matrix gyalukések	124 - 126
	EN T.C.T. and solid carbide planer knives DE HM-bestückte und Vollhartmetall-Hobelmesser FR Couteaux à mise rapportée carbure et couteaux à raboter au carbure massif IT Coltelli da pialla con metallo duro riportato e coltelli da pialla in HM integrale HU Vídiabetés és tömörvídia gyalukések	126 - 127



- EN Planer knives - Grades and their applications  
 DE Hobelmesser - Sorten und ihre Anwendungen  
 FR Couteaux à raboter - Les nuances et leurs applications  
 IT Coltelli da pialla - I tipi e le loro applicazioni  
 HU Gyalukések - Kategóriák és felhasználásuk

EN TIGRA grade DE TIGRA - Sorte FR Nuance TIGRA IT Tipo TIGRA HU TIGRA kategória	Compositon Zusammensetzung Composition Composizione Összetétel	Hardness Härte Dureté Durezza Keménység	Toughness Zähigkeit Ténacité Tenacità Szívósság	Bending strength Biegebruchfestigkeit Résistance à la flexion Resistenza flessionale Hajlítószilárdság	EN HDF DE HDF FR HDF IT HDF HU HDF	MDF MDF MDF MDF MDF	Chipboard Spanplatte Panneaux de particule Truciolare Forgácslap	Hardwood Hartholz Bois dur Legno duro Keményfa	Softwood Weichholz Bois tendre Legno tenero Puhafa	Main usage Hauptverwendung Usage principal Usò principale Fő alkalmazási terület
HSS	6 % W / M2	↘	↗	↗	☐	☐	☐	✓	✓	EN Standard HSS grade, wood DE Standard-HSS-Sorte, Holz FR Nuance HSS standard, bois IT HSS standard, legno HU Standard HSS kategória, fához
HSS 18 %	18 % W / T1	↗	↗	↗	☐	☐	○	✓	✓	EN Best HSS grade, wood DE Beste HSS-Sorte, Holz FR Meilleure nuance HSS, bois IT Migliore HSS, legno HU Legjobb HSS kategória, fához
HSS M42	M42	↗	↗	↗	☐	☐	☐	✓	✓	EN Special HSS grade, wood DE Spezial-HSS-Sorte, Holz FR Nuance HSS spéciale, bois IT HSS speciale, legno HU Speciális HSS kategória, fához
H.P.S.	CrV	↘	↗	↗	☐	☐	☐	○	✓	EN Softwood, low price demands DE Weichholz, preisgünstig FR Bois tendre, pris bas IT Legni teneri, costo basso HU Puhafához, alacsony árígénynél
T.C.T.	vídiafogás	↗	↗	↘	○	✓	✓	✓	○	EN High lifetime demands DE Hohe Standzeitanforderungen FR Applications de durabilité maximisé IT Elevata esigenza di durata HU Magas él(et)tartamigény esetén
Tömör vídia	T10MG	↗	↗	↗	✓	✓	✓	✓	✓	EN Highest lifetime demands DE Höchste Standzeitanforderungen FR Très longue durée de vie et nombreux services IT Massima esigenza di durata HU Legmagasabb él(et)tartamigény esetén
	!!! T12SMG 	↗	↗	↗	✓	✓	✓	✓	✓	EN Highest lifetime and surface quality DE Höchste Lebensdauer und Oberflächenqualität FR La plus haute qualité de vie et de surface IT Maggiore durata e qualità della superficie HU Legjobb él(et)tartam és felületminőség
Matrix	speciális bevonat	↗	↗	↗	☐	☐	☐	✓	✓	EN Very long lifetime with multiple resharpening DE Sehr lange Lebensdauer durch mehrfaches Nachschärfen FR Très longue durée de vie et nombreux services IT Durata molto lunga con affilatura multipla HU Nagyon hosszú él(et)tartam többszöri élezhetőséggel

- ✓ kiváló teljesítőképesség  
 ↗ nagyon jó tejesítményü  
 ○ elfogadható  
 ☐ nem alkalmas

EN For technical data, please refer to the pages 8-10.  
 DE Die technischen Daten entnehmen Sie bitte den Seiten 8-10.  
 FR Pour les données techniques, veuillez voir aux pages 8-10.

IT Per i dati tecnici, fare riferimento alle pagine 8-10.  
 HU A műszaki adatokat a 8-10. oldalon találja.

- EN Premium planer knives with polished grinding in carbide grade T12SMG  
 DE Premium-Hobelmesser mit Polierschliff in der Hartmetallsorte T12SMG  
 FR Couteaux à raboter premium avec affûtage poli miroir en nuance de carbure T12SMG  
 IT Coltelli da pialla di alta qualità con affilatura lappata in metallo duro tipo T12SMG  
 HU Prémium gyalukések polírozott élköszörüléssel T12SMG vídia kategóriában

**ÚJ**

# T12SMG

**PREMIUM Products**

System TERSA  
 System CENTROLOCK  
 System CENTROFIX/  
 CENTROSTAR/  
 QUICKFIX  
 System VARIPLAN  
 System SINUS  
 System ENSHIN  
 System ENSHIN 8-B  
 System ENSHIN 8-C  
 System Bulldozer

EN Best surface quality due to highly polished cutting edges and finest grain carbide  
 Up to 40 % longer tool life compared to standard carbide knives on the market  
 DE Beste Oberflächengüte durch hochglanzpolierte Schneidkanten und Feinstkornhartmetall  
 Bis zu 40 % höhere Standwege gegenüber marktüblichen HM-Messern  
 FR Excellente qualité de surface grâce aux arêtes de coupe polies miroir et au carbure à grain fin  
 Jusqu'à 40 % plus de durée de vie en comparaison avec les couteaux en carbure de tungstène disponibles sur le marché  
 IT Migliore qualità della superficie, grazie ai taglienti lappati e al metallo duro con grano finissimo  
 Durata dell'utensile fino al 40 % in più, rispetto ai coltelli in metallo duro standard presenti sul mercato  
 HU A legjobb felületminőség a magsfényűre polírozott vágóéleknek és finomszemcsés vídiának köszönhetően.  
 Akár 40%-kal meghosszabbodott él(et)tartam a többi piaci szereplőéhez képest.-

- EN Further technical information  
 DE Weitere technische Informationen  
 FR Plus d'informations techniques  
 IT Ulteriori informazioni tecniche  
 HU További műszaki információk

**Black Oxide**

EN HSS Black Oxide\*  
 Optimum HSS system planer knives with hardened cutting edges  
 HU HSS Black Oxide\*  
 Optimalizált HSS-Rendszer-gyalukés edzett vágóélekkel

hard soft hard

EN Optimized distribution of hardness  
 The unique manufacturing process maneuvers hardness to where it belongs: the cutting edge. The core of the knife remains soft to help protect against breakage and to also increase the ease of an eventual straightening.  
 Polished cutting edge  
 For an extra-aggressive cut in the wood, the cutting edge has a second, partial polish grind.  
 Black Oxide Surface  
 The thin black surface layer of ferric oxide, only nanometers thick, runs across the top and bottom. This improves corrosion resistance and prevents early rusting.  
 HU Optimális keménységeloszlás  
 A speciális gyártási eljárás révén a keménység pontosan oda összpontosul, ahol szükség van rá: a vágóélekben. A kés magja lágy és rugalmas marad, ami a törést megelőzi és egyszerűbbé teszi az esetleges kiegyengetést/újraélezést követően.  
 Polírozott vágóél  
 Különösen agresszív bevezetés a fában és nygaon jó fafelület érdekében a vágóélnak van egy második, polírozó köszörülése is.  
 Black Oxide felület  
 A néhány nanométer vastag fekete vasoxid bevonat a felső és az alsó oldalon a kést ellenállóvá teszi a korrózióval szemben megakadályozza az idő előtti rozsdásodást.

**Matrix Coating**

Matrix Coating Technology\* - Special coating for longest tool life  
 Matrix Coating Technology\* - Speciális bevonat a leghosszabb él(et)tartamért

EN Unique coating for maximum lifetime requirements  
 • Tool life is on average 3-5 times longer  
 • Coating penetrates into the material  
 • Still significantly longer tool life after resharpening  
 • Smoother surface  
 • Applications: thin planer knives, back corrugated systems, reversible knives  
 DE Egyedülálló bevonat a legnagyobb él(et)tartam igényekre  
 • Átlagosan 3-5-szörös él(et)tartam  
 • A bevonat behatol az anyagba  
 • Újraélezést követően is még jelenősen meghosszabbodott éltartam  
 • Sima felület  
 • Alkalmazás: vékony gyalukések, bordáshátú rendszerek, rückenverzahnte Systeme, váltólapkák

\* EN Please compare with the pages 9-10.  
 \* DE Bitte vergleichen Sie mit den Seiten 9-10.  
 \* FR Veuillez comparer avec les pages 9-10.  
 \* IT Confrontate con le pagine 9-10.  
 \* HU Vesse össze a 9-10. oldalal

EN Reversible knives for portable planers  
 DE Wendeschneidplatten für Handhobel  
 FR Plaquettes pour rabots électro portatifs  
 IT Coltelli per piallatrici portatili  
 HU Megfordítható kések hordozható gyalugépekhez

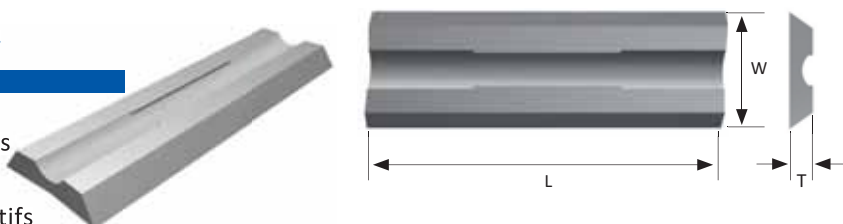

	L mm	W mm	T mm	Art.	
	56.0	5.5	1.1	013041	Adler
	75.5	5.5	1.1	013001	AEG, Bosch, Festo, Haffner, Kress, Mafell, Metabo, Scheer, Skil, Holz-Her
	78.0	5.5	1.1	013067	Virutex
	102.0	5.5	1.1	013061	AEG
	80.5	5.5	1.1	013010	ELU
	80.5	5.9	1.2	013043	ELU
	82.0	5.5	1.1	013020	AEG, B&D, Bosch, ALU, Fein, Felisatti, Haffner, Hitachi, Holz-Her, Mafell, Makita, Metabo, Peugeot, Ryobi, Skil

EN System Planer knives  
 DE Systemhobelmesser  
 FR Couteaux à raboter pour système  
 IT Coltelli da pialla per sistema  
 HU Típusrendszerek gyalukései

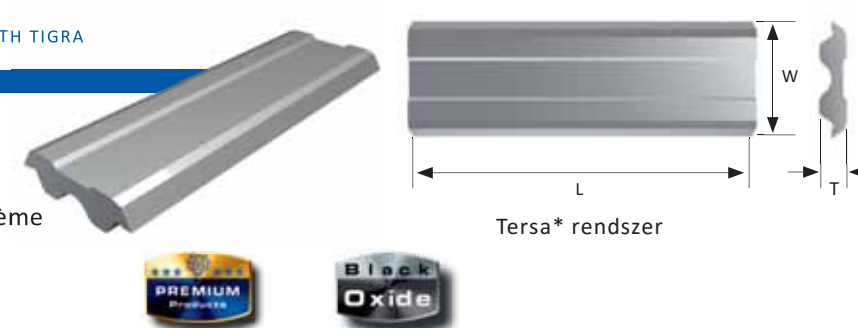

L mm	W mm	T mm	T10MG	T12SMG polírozott	HSS 6% (M2)	HSS 18% (T1)	HSS M42
60.0	10.0	2.3	100847	159876	100395	114482	114539
80.0	10.0	2.3	100848	159945	100396	114484	114541
90.0	10.0	2.3	104398	159946	107546	114485	114542
100.0	10.0	2.3	055509	159948	100397	114487	114544
110.0	10.0	2.3	100849	159949	100398	114488	114545
115.0	10.0	2.3	105071	159950	104630	114489	114546
120.0	10.0	2.3	100851	159951	100399	114490	114547
125.0	10.0	2.3	104022	159952	107548	114491	114548
130.0	10.0	2.3	055510	159953	100400	114492	114549
135.0	10.0	2.3	103823	159954	103821	114493	114550
140.0	10.0	2.3	104766	159955	104613	114494	114551
150.0	10.0	2.3	100852	159957	100401	114496	114553
160.0	10.0	2.3	103943	159958	102716	114497	114554
170.0	10.0	2.3	100853	159959	100402	114498	114555
180.0	10.0	2.3	100854	159960	100403	114499	114556
185.0	10.0	2.3	105070	159961	102774	114500	114557
190.0	10.0	2.3	104399	159962	104808	114501	114558
200.0	10.0	2.3	105698	159964	104243	114502	114559
210.0	10.0	2.3	100855	159965	100404	114503	114560
220.0	10.0	2.3	104589	159966	104566	114504	114561
230.0	10.0	2.3	055511	159967	100405	114505	114562
235.0	10.0	2.3	103824	159968	101718	114506	114563
240.0	10.0	2.3	104043	159969	101720	114507	114564
250.0	10.0	2.3	100856	159970	100406	114508	114565
260.0	10.0	2.3	100857	159971	100407	114509	114566
265.0	10.0	2.3	104573	159972	104326	114510	114567
270.0	10.0	2.3	101673	159973	102982	114511	114568

\* EN For use in Tersa-cutterheads only  
 \* DE Nur zur Verwendung in Tersa-Messerköpfen  
 \* FR Utilisation limitée aux porte outils de Tersa  
 \* IT Da usare solo su teste portacoltelli della Tersa  
 \* EU Csak Tersa gyártmányú késfejekhez használható



EN System Planer knives  
 DE Systemhobelmesser  
 FR Couteaux à raboter pour système  
 IT Coltelli da pialla per sistema  
 HU Típusrendszerek gyalukései

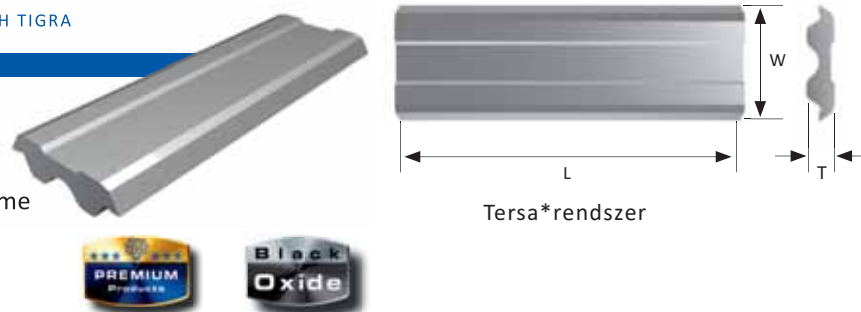

L mm	W mm	T mm	T10MG	T12SMG polírozott	HSS 6% (M2)	HSS 18% (T1)	HSS M42	H.P.S.
280.0	10.0	2.3	100858	159974	100408	114512	114569	
300.0	10.0	2.3	100859	159975	100409	114513	114570	
310.0	10.0	2.3	055512	159976	100410	114514	114571	
320.0	10.0	2.3	107550	159977	104687	114515	114572	
330.0	10.0	2.3	100861	159978	100411	114516	114573	
350.0	10.0	2.3	100862	159979	100412	114517	114574	
360.0	10.0	2.3	100863	159980	100413	114518	114575	
400.0	10.0	2.3	100864	159981	100414	114519	114576	
410.0	10.0	2.3	055513	159982	100415	114520	114577	
415.0	10.0	2.3	107551	159983	105267	114521	114578	
420.0	10.0	2.3	100865	159984	100416	114522	114579	
430.0	10.0	2.3	055514	159985	100417	114523	114580	
450.0	10.0	2.3	100866	159986	100418	114524	114581	
500.0	10.0	2.3	100867	159987	100419	114525	114582	
510.0	10.0	2.3	055515	159988	100420	114526	114583	
520.0	10.0	2.3	055516	159989	100421	114527	114584	
530.0	10.0	2.3	100868	159990	100422	114528	114585	
540.0	10.0	2.3	100869	159991	100423	114529	114586	
600.0	10.0	2.3	104720	159992	103994	114530	114587	
610.0	10.0	2.3	055517	159993	100424	114531	114588	
630.0	10.0	2.3	055518	159994	100425	114532	114589	
635.0	10.0	2.3	102179	159995	103912	114533	114590	
640.0	10.0	2.3	100870	159996	100426	114534	114591	
650.0	10.0	2.3	055519	159997	100427	114535	114592	
710.0	10.0	2.3			114119	114536	114593	
810.0	10.0	2.3			113435	114537	114594	
1050.0	10.0	2.3			114599	114538	114595	
Coil 60 meters					115127	116526	115128	
Coil 120 meters					110719	115191	114791	115120
Packing paper coil (60 meters for paired packing)					112874	112874	112874	112874

\* EN For use in Tersa-cutterheads only  
 \* DE Nur zur Verwendung in Tersa-Messerköpfen  
 \* FR Utilisation limitée aux porte outils de Tersa  
 \* IT Da usare solo su teste portacoltelli della Tersa  
 \* HU Csak Tersa gyártmányú késfejekhez használható

EN System Planer knives  
 DE Systemhobelmesser  
 FR Couteaux à raboter pour système  
 IT Coltelli da pialla per sistema  
 HU Típusrendszerek gyalukései



L mm	W mm	T mm	T10MG	T12SMG polírozott	HSS 18% (T1)
10.0	16.0	3.0	102953	160012	114697
30.0	16.0	3.0	102777	160014	114699
40.0	16.0	3.0	102954	160015	114700
50.0	16.0	3.0	102778	160016	114701
60.0	16.0	3.0	100837	160017	114702
65.0	16.0	3.0	107536	160018	114703
80.0	16.0	3.0	100838	160019	114704
100.0	16.0	3.0	055502	160020	114705
115.0	16.0	3.0	106848	160021	114706
130.0	16.0	3.0	055503	160022	114707
140.0	16.0	3.0	107537	160023	114708
150.0	16.0	3.0	100839	160024	114709
160.0	16.0	3.0	105003	160025	114710
170.0	16.0	3.0	055504	160026	114711
180.0	16.0	3.0	100840	160028	114712
190.0	16.0	3.0	100841	160029	114713
210.0	16.0	3.0	100842	160030	114714
220.0	16.0	3.0	107538	160031	114715
230.0	16.0	3.0	054753	160032	114716
235.0	16.0	3.0	100844	160033	114717
240.0	16.0	3.0	055505	160034	114718
260.0	16.0	3.0	100845	160035	114719
270.0	16.0	3.0	055506	160036	114720
285.0	16.0	3.0	125900	160037	122896
300.0	16.0	3.0	102493	160038	114721
310.0	16.0	3.0	100846	160039	114722
460.0	16.0	3.0	055507	160040	114723
650.0	16.0	3.0	055508	160041	114724
1050.0	16.0	3.0			114727

\* EN For use in Centrolock-cutterheads only  
 \* DE Nur zur Verwendung in Centrolock-Messerköpfen  
 \* FR Utilisation limitée aux porte outils de Centrolock  
 \* IT Da usare solo su teste portacoltelli della Centrolock  
 \* HU Csak Centrolock gyártmányú késfejekhez használható



EN System Planer knives  
 DE Systemhobelmesser  
 FR Couteaux à raboter pour système  
 IT Coltelli da pialla per sistema  
 HU Típusrendszerek gyalukései

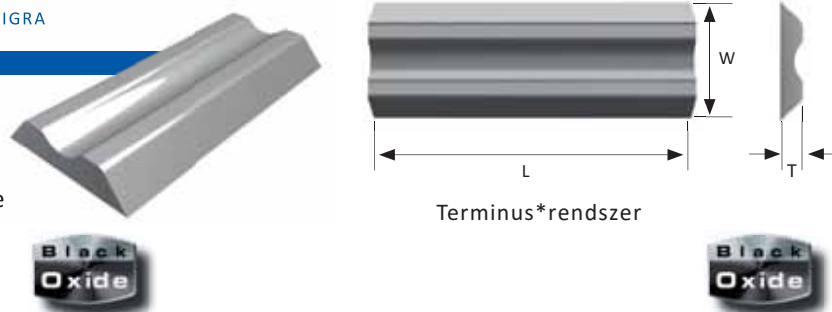

L mm	W mm	T mm	T10MG	HSS 18% (T1)
50.0	14.0	2.55	100796	114649
60.0	14.0	2.55	100803	114650
80.0	14.0	2.55	100804	114651
100.0	14.0	2.55	100805	114652
110.0	14.0	2.55	100806	114653
120.0	14.0	2.55	100807	114654
130.0	14.0	2.55	055496	114655
136.0	14.0	2.55	107532	114656
140.0	14.0	2.55	100808	114657
150.0	14.0	2.55	100809	114658
160.0	14.0	2.55	100811	114659
170.0	14.0	2.55	100812	114660
180.0	14.0	2.55	100813	114661
190.0	14.0	2.55	100814	114662
200.0	14.0	2.55	100815	114663
210.0	14.0	2.55	100816	114664
220.0	14.0	2.55	100817	114665
230.0	14.0	2.55	054752	114666
240.0	14.0	2.55	100818	114667
250.0	14.0	2.55	100819	114668
255.0	14.0	2.55	107533	114669
260.0	14.0	2.55	100820	114670
270.0	14.0	2.55	100821	114671
275.0	14.0	2.55	107534	114672
280.0	14.0	2.55	100822	114673

L mm	W mm	T mm	T10MG	HSS 18% (T1)
300.0	14.0	2.55	100823	114674
310.0	14.0	2.55	055497	114675
330.0	14.0	2.55	107535	114676
350.0	14.0	2.55	100824	114677
360.0	14.0	2.55	100825	114678
400.0	14.0	2.55	100826	114679
410.0	14.0	2.55	055498	114680
420.0	14.0	2.55	100828	114681
430.0	14.0	2.55	100829	114682
450.0	14.0	2.55	100830	114683
480.0	14.0	2.55	100940	114684
500.0	14.0	2.55	104977	114685
510.0	14.0	2.55	055499	114686
520.0	14.0	2.55	100831	114687
530.0	14.0	2.55	100832	114688
610.0	14.0	2.55	055500	114689
620.0	14.0	2.55	100833	114690
630.0	14.0	2.55	100834	114691
640.0	14.0	2.55	100835	114692
710.0	14.0	2.55		114694
810.0	14.0	2.55		114695
1050.0	14.0	2.55		114696

\* EN For use in Terminus-cutterheads only  
 \* DE Nur zur Verwendung in Terminus-Messerköpfen  
 \* FR Utilisation limitée aux porte outils de Terminus  
 \* IT Da usare solo su teste portacoltelli della Terminus  
 \* HU Csak Terminus gyártmányú késfejekhez használható

EN System Planer knives  
 DE Systemhobelmesser  
 FR Couteaux à raboter pour système  
 IT Coltelli da pialla per sistema  
 HU Típusrendszerek gyalukései



L mm	W mm	T mm	T10MG	T12SMG polished	HSS 6% (M2)	HSS 18% (T1)
50.0	12.0	2.7	100876	161477	100896	114762
80.0	12.0	2.7	100879	161478	100897	114763
100.0	12.0	2.7	100880	161479	100898	114764
120.0	12.0	2.7	100881	161480	100899	114765
130.0	12.0	2.7	055520	161481	055488	114766
136.0	12.0	2.7	100883	161482	100900	114767
150.0	12.0	2.7	100884	161483	100901	114768
170.0	12.0	2.7	100885	161484	100902	114769
180.0	12.0	2.7	055521	161485	055489	114770
190.0	12.0	2.7	100886	161486	100904	114771
210.0	12.0	2.7	100887	161487	100905	114772
230.0	12.0	2.7	055522	161489	055490	114773
240.0	12.0	2.7	100890	161490	100906	114774
260.0	12.0	2.7	111091	161491	110036	116026
310.0	12.0	2.7	101675	161492	103165	114775
400.0	12.0	2.7	100891	161493	100907	114776
410.0	12.0	2.7	055523	161494	055491	114777
420.0	12.0	2.7	100892	161495	100908	114778
430.0	12.0	2.7	100893	161496	100909	114779
500.0	12.0	2.7	100894	161497	100910	114780
510.0	12.0	2.7	055524	161498	055492	114781
520.0	12.0	2.7	055525	161499	055493	114782
530.0	12.0	2.7	055526	161500	055494	114783
630.0	12.0	2.7	107553	161502	103814	114785
640.0	12.0	2.7	107554	161503	107474	114786
650.0	12.0	2.7	055527	161504	055495	114787
710.0	12.0	2.7			101046	114788
810.0	12.0	2.7			108226	114789
1050.0	12.0	2.7			114760	114790
Tekercs 120 meter					112205	
Csomagolópapír tekercs (60 meter páros csomagoláshoz)					112877	

\* EN For use in Centrofix/Centrostar/Quickfix-cutterheads only  
 \* DE Nur zur Verwendung in Centrofix/Centrostar/Quickfix-Messerköpfen  
 \* FR Utilisation limitée aux porte outils de Centrofix/Centrostar/Quickfix  
 \* IT Da usare solo su teste portacoltelli della Centrofix/Centrostar/Quickfix  
 \* HU Csak Centrofix/Centrostar/Quickfix gyártmányú késfejekhez használható

EN System Planer knives  
 DE Systemhobelmesser  
 FR Couteaux à raboter pour système  
 IT Coltelli da pialla per sistema  
 HU Típusrendszerek gyalukései

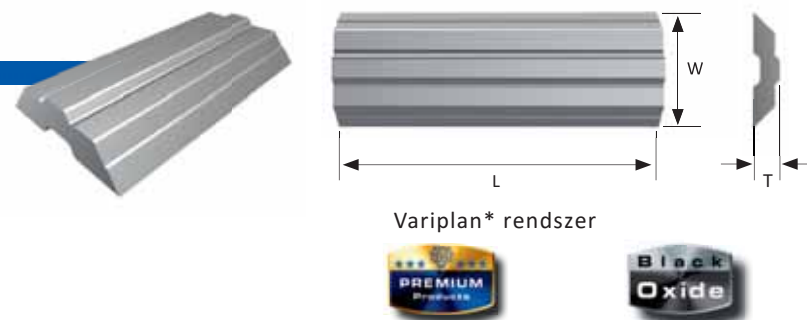

L mm	W mm	T mm	T10MG	T12SMG polirozott	HSS 18% (T1)
80	16.0	3.7	116766	159910	116739
100	16.0	3.7	116767	159911	116740
120	16.0	3.7	116768	159912	116741
130	16.0	3.7	109662	159913	116319
136	16.0	3.7	116769	159914	116742
150	16.0	3.7	116770	159915	116743
170	16.0	3.7	108654	159916	116744
180	16.0	3.7	116771	159917	116745
190	16.0	3.7	116772	159918	116746
210	16.0	3.7	107585	159919	116747
230	16.0	3.7	116773	159920	116320
240	16.0	3.7	116774	159921	116321
400	16.0	3.7	116775	159922	116748
410	16.0	3.7	107586	159923	116322
500	16.0	3.7	116778	159926	116751
510	16.0	3.7	116779	159927	116752
520	16.0	3.7	116780	159928	116753
530	16.0	3.7	116781	159929	116754
540	16.0	3.7	116782	159930	116755
600	16.0	3.7	116783	159931	116756
630	16.0	3.7	116785	159933	116758
640	16.0	3.7	116786	159934	116759
1050	16.0	3.7			115845

\* EN For use in Variplan-cutterheads only  
 \* DE Nur zur Verwendung in Variplan-Messerköpfen  
 \* FR Utilisation limitée aux porte outils de Variplan  
 \* IT Da usare solo su teste portacoltelli della Variplan  
 \* HU Csak Variplan gyártmányú késfejekhez használható

EN System Planer knives  
 DE Systemhobelmesser  
 FR Couteaux à raboter pour système  
 IT Coltelli da pialla per sistema  
 HU Típusrendszerek gyalukései



L mm	W mm	T mm	T10MG	T12SMG polirozott	HSS 18% (T1)
80	16.0	2.5	116711	159874	130320
100	16.0	2.5	116712	159880	116681
120	16.0	2.5	116713	159881	130322
130	16.0	2.5	116714	159882	130323
150	16.0	2.5	116716	159884	130325
160	16.0	2.5	116717	159885	130326
180	16.0	2.5	116718	159886	130327
190	16.0	2.5	116719	159887	130328
200	16.0	2.5	116720	159888	130329
210	16.0	2.5	116721	159889	130330
230	16.0	2.5	116723	159891	128353
240	16.0	2.5	116724	159893	128354
250	16.0	2.5	116725	159894	130331
260	16.0	2.5	116726	159895	130332
300	16.0	2.5	116727	159896	130333
310	16.0	2.5	116728	159897	130334
400	16.0	2.5	116729	159898	130335
410	16.0	2.5	116730	159899	130336
500	16.0	2.5	116732	159901	130338
510	16.0	2.5	116733	159902	130339
610	16.0	2.5	116734	159903	130292
630	16.0	2.5	116735	159904	130340
640	16.0	2.5	116736	159905	130341
1050	16.0	2.5			130343
1350	16.0	2.5			115486

\* EN For use in Sinus-cutterheads only  
 \* DE Nur zur Verwendung in Sinus-Messerköpfen  
 \* FR Utilisation limitée aux porte outils de Sinus  
 \* IT Da usare solo su teste portacoltelli della Sinus  
 \* HU Csak Sinus gyártmányú késfejekhez használható

EN System Planer knives  
 DE Systemhobelmesser  
 FR Couteaux à raboter pour système  
 IT Coltelli da pialla per sistema  
 HU Típusrendszerek gyalukései sistema

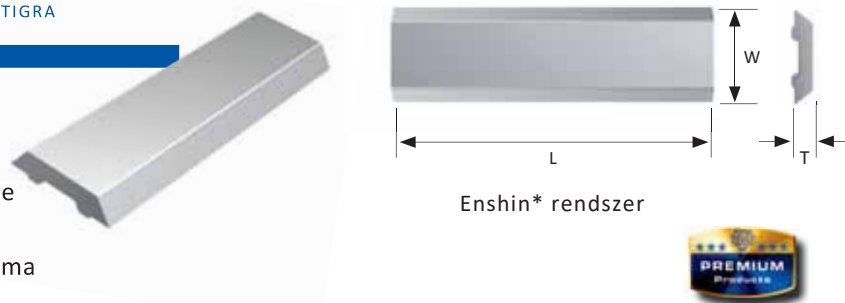

	L	W	T	T10MG	T12SMG
	mm	mm	mm		polírozott
	80	12.7	2.6	116794	159853
	100	12.7	2.6	116796	159854
	130	12.7	2.6	116797	159855
	150	12.7	2.6	116798	159856
	170	12.7	2.6	116799	159857
	180	12.7	2.6	116800	159858
	190	12.7	2.6	116801	159859
	210	12.7	2.6	116802	159860
	230	12.7	2.6	116803	159861
	240	12.7	2.6	116804	159862
	640	12.7	2.6	116805	159863



	L	W	T	HSS
	mm	mm	mm	6% (M2)
	80	12.0	2.7	116787
	100	12.0	2.7	116788
	130	12.0	2.7	116316
	150	12.0	2.7	116789
	170	12.0	2.7	116790
	180	12.0	2.7	116317
	190	12.0	2.7	116791
	210	12.0	2.7	116792
	230	12.0	2.7	116318
	240	12.0	2.7	116793
	1050	12.0	2.7	115846

\* EN For use in Enshin-cutterheads only  
 \* DE Nur zur Verwendung in Enshin-Messerköpfen  
 \* FR Utilisation limitée aux porte outils de Enshin  
 \* IT Da usare solo su teste portacoltelli della Enshin  
 \* HU Csak Enshin gyártmányú késfejekhez használható

EN System Planer knives  
 DE Systemhobelmesser  
 FR Couteaux à raboter pour système  
 IT Coltelli da pialla per sistema  
 HU Típusrendszerek gyalukései sistema

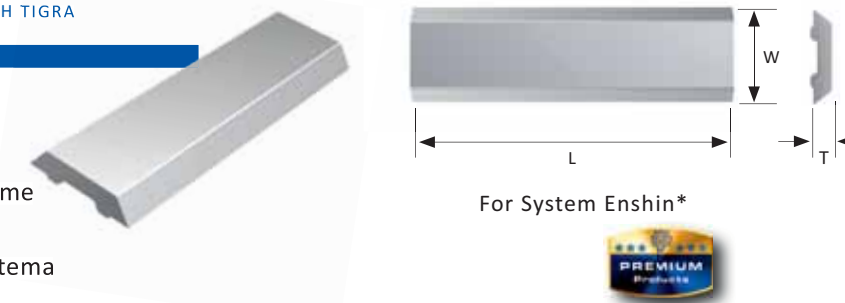

	L	W	T	T12SMG
	mm	mm	mm	
	100	8	2	161505
	130	8	2	161506
	160	8	2	161507
	180	8	2	161508
	230	8	2	161509
	250	8	2	161510
	260	8	2	161511
	300	8	2	161512
	400	8	2	161513
	450	8	2	161514
500	8	2	161515	
510	8	2	161516	
650	8	2	161517	

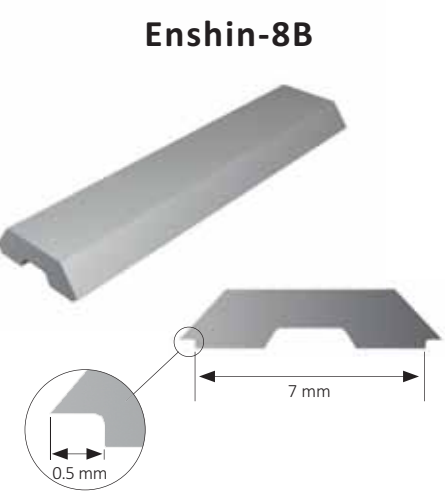

	L	W	T	T12SMG
	mm	mm	mm	
	100	8	2	161518
	130	8	2	161519
	160	8	2	161520
	180	8	2	161521
	230	8	2	161522
	250	8	2	161523
	260	8	2	161524
	300	8	2	161526
	400	8	2	161527
	450	8	2	161528
500	8	2	161529	
510	8	2	161530	
650	8	2	161531	

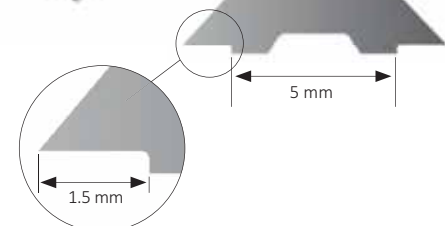

\* EN For use in Enshin-cutterheads only  
 \* DE Nur zur Verwendung in Enshin-Messerköpfen  
 \* FR Utilisation limitée aux porte outils de Enshin  
 \* IT Da usare solo su teste portacoltelli della Enshin  
 \* HU Csak Enshin gyártmányú késfejekhez használható

EN System Planer knives  
 DE Systemhobelmesser  
 FR Couteaux à raboter pour système  
 IT Coltelli da pialla per sistema  
 HU Típusrendszerek gyalukéra.sistema

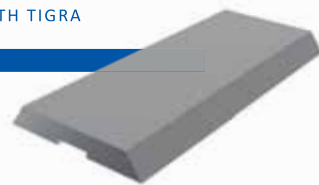

Bulldozer rendszer



L mm	W mm	T mm	T10MG	T12SMG polirozott
60.0	13.6	1.8	047422	161533
70.0	13.6	1.8	013728	161534
80.0	13.6	1.8	046288	161535
100.0	13.6	1.8	013713	161536
110.0	13.6	1.8	047423	161537
120.0	13.6	1.8	013715	161538
130.0	13.6	1.8	013716	161539
140.0	13.6	1.8	013723	161540
150.0	13.6	1.8	013718	161541
160.0	13.6	1.8	013726	161542
180.0	13.6	1.8	013719	161543
190.0	13.6	1.8	013725	161544
200.0	13.6	1.8	013720	161545
220.0	13.6	1.8	049247	161546
230.0	13.6	1.8	013721	161547
240.0	13.6	1.8	040337	161548
245.0	13.6	1.8	038423	161552
250.0	13.6	1.8	013722	161549
260.0	13.6	1.8	035440	161550

EN System Planer knives  
 DE Systemhobelmesser  
 FR Couteaux à raboter pour système  
 IT Coltelli da pialla per sistema  
 HU Típusrendszerek gyalukései



Barke/Brück/ESTA rendszer

L mm	W mm	T mm	H.P.S.	HSS M42	Alkalmazható ...	L mm	W mm	T mm	Támasztólap
110.0	19.0	1.0	101798	142053	Mafell	110.0	25.0	2.0	142369
115.0	18.6	1.0	142069	142104		120.0	25.0	2.0	142370
120.0	19.0	1.0	051731	142106		130.0	25.0	2.0	142371
130.0	19.0	1.0	049685	142107		150.0	25.0	2.0	142372
150.0	19.0	1.0	131397	142108					
161.0	19.0	1.0	142074	142109	pl. Mafell				
170.0	18.6	1.0	142362	142363	Mafell				
180.0	19.0	1.0	109998	142111		180.0	25.0	2.0	142374
186.0	19.0	1.0	142070	142112		186.0	25.0	2.0	142375
190.0	19.0	1.0	051730	142113		190.0	25.0	2.0	142376
200.0	19.0	1.0	130305	142115	HolzHer / ProTool / Festool	200.0	25.0	2.0	142377
205.0	19.0	1.0	142075	142116		230.0	25.0	2.0	142378
230.0	19.0	1.0	050210	142127					
245.0	19.0	1.0	142072	142128	HolzHer / ProTool / Festool	250.0	25.0	2.0	142379
250.0	19.0	1.0	142073	142129					
260.0	17.2	1.0	142365	-	Scheppach	260.0	16.6	2.0	142380
260.0	19.0	1.0	127955	142133	<u>Nem jó</u> Felderhez	260.0	25.0	2.0	142381
280.0	18.6	1.0	142099	142153	Mafell				
300.0	19.0	1.0	142100	142154	HolzHer / ProTool / Makita				
310.0	19.0	1.0	130306	142155	<u>Nem jó</u> Felderhez/Hammer	310.0	25.0	2.0	142383
320.0	17.2	1.0	142366	-	Scheppach	320.0	16.6	2.0	142384
320.0	18.6	1.0	142367	142368	Mafell				
320.0	19.0	1.0	101799	142156		320.0	25.0	2.0	142385
350.0	19.0	1.0	134298	142157	HolzHer / ProTool	400.0	25.0	2.0	142386
400.0	19.0	1.0	133960	142158					
410.0	19.0	1.0	113338	142159	<u>Nem jó</u> Felderhez/Hammer	410.0	25.0	2.0	142387
500.0	19.0	1.0	110742	142160		500.0	25.0	2.0	142388
510.0	19.0	1.0	109381	142161	<u>Nem jó</u> Felderhez	510.0	25.0	2.0	142389
520.0	19.0	1.0	142101	142162		520.0	25.0	2.0	142390
530.0	19.0	1.0	133883	142163		530.0	25.0	2.0	142391
610.0	19.0	1.0	142102	142164		610.0	25.0	2.0	142392
630.0	19.0	1.0	108937	142165		630.0	25.0	2.0	142393
640.0	19.0	1.0	132415	142166		640.0	25.0	2.0	142394

EN The backing plates are also available in W = 18 mm.  
 DE Stützplatten sind auch in W = 18 mm lieferbar.  
 FR Les porte-plaquettes sont également disponibles en W = 18 mm.  
 IT Le piastre di supporto sono anche disponibili in W = 18 mm.  
 HU W = 18 mm-es nyomódúcok is kaphatók.



EN HSS/Matrix planer knives  
 DE HSS/Matrix Hobelmesser  
 FR Fers de raboteuse HSS/Matrix  
 IT Coltelli da pialla HSS/Matrix  
 HU HSS/Matrix gyalukések

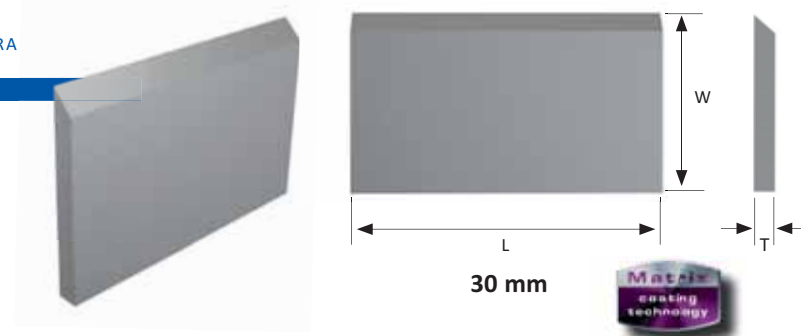

L mm	W mm	T mm	HSS 6% (M2)	HSS 18% (T1)	Matrix bevonat technológia
60	30.0	3.0	030152	111908	120140
80	30.0	3.0	030153	111913	120141
100	30.0	3.0	030154	111914	120142
120	30.0	3.0	030157	111916	120144
130	30.0	3.0	030159	111917	120145
150	30.0	3.0	030162	111918	120146
160	30.0	3.0	030163	111919	120147
170	30.0	3.0	030164	111920	120148
180	30.0	3.0	030165	111921	120149
210	30.0	3.0	030168	111922	120150
230	30.0	3.0	030171	111923	120151
240	30.0	3.0	030172	111924	120153
260	30.0	3.0	030174	111925	120154
300	30.0	3.0	030175	111926	120155
310	30.0	3.0	030176	111927	120156
350	30.0	3.0	030178	111928	120157
400	30.0	3.0	030182	111929	120158
410	30.0	3.0	030183	111930	120159
500	30.0	3.0	030186	111931	120160
510	30.0	3.0	030187	111932	120161
520	30.0	3.0	101376	111933	120162
530	30.0	3.0	030188	111934	120163
600	30.0	3.0	030190	111935	120164
610	30.0	3.0	030191	111936	120165
630	30.0	3.0	030192	111937	120166
640	30.0	3.0	030194	111938	120167
710	30.0	3.0	030198	111939	120168
810	30.0	3.0	030201	111940	120169
820	30.0	3.0	101051	111941	120170
1050	30.0	3.0	030249	111942	120171

EN HSS/Matrix planer knives  
 DE HSS/Matrix Hobelmesser  
 FR Fers de raboteuse HSS/Matrix  
 IT Coltelli da pialla HSS/Matrix  
 HU HSS/Matrix gyalukések

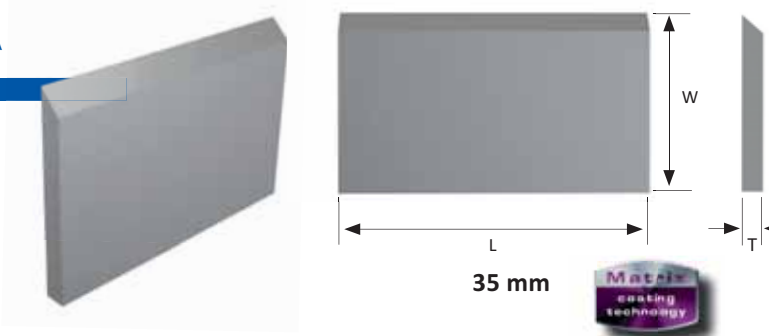

L mm	W mm	T mm	HSS 6% (M2)	HSS 18% (T1)	Matrix bevonat technológia
60	35.0	3.0		111944	120173
80	35.0	3.0		111945	120174
100	35.0	3.0		111946	120175
110	35.0	3.0		111947	120176
120	35.0	3.0		111948	120178
130	35.0	3.0	030210	111949	120179
150	35.0	3.0	030211	111950	120180
160	35.0	3.0	030212	111951	120181
170	35.0	3.0	030213	111952	120182
180	35.0	3.0	030214	111953	120183
210	35.0	3.0	030217	111954	120185
230	35.0	3.0	030218	111955	120186
240	35.0	3.0	107570	111956	120188
260	35.0	3.0	030220	111957	120189
300	35.0	3.0	048006	111958	120190
310	35.0	3.0	030222	111959	120191
350	35.0	3.0	107571	111960	120192
400	35.0	3.0	030225	111961	120193
410	35.0	3.0	030226	111962	120194
500	35.0	3.0	030230	111963	120195
510	35.0	3.0	030231	111964	120196
520	35.0	3.0	030232	111965	120197
530	35.0	3.0	030233	111966	120198
600	35.0	3.0	030234	111967	120199
610	35.0	3.0	030235	111968	120200
630	35.0	3.0	030236	111969	120201
640	35.0	3.0	030237	111970	
710	35.0	3.0	030240	111971	
810	35.0	3.0	030243	111972	
820	35.0	3.0	101052	111973	
1050	35.0	3.0	030252	111974	120208

EN HSS planer knives  
 DE HSS Hobelmesser  
 FR Fers de raboteuse HSS  
 IT Coltelli da pialla HSS  
 HU HSS gyalukések

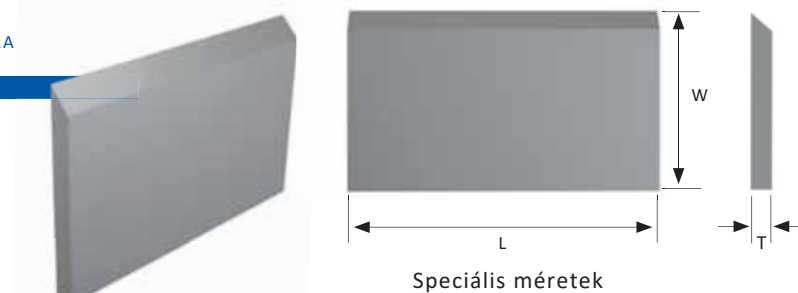

L mm	W mm	T mm	HSS 6% (M2)	HSS 18% (T1)
1050	20.0	2.5	106992	122065
1050	25.0	2.5	106994	116185
1050	20.0	3.0	101943	122007
1050	25.0	3.0	101030	111975
1050	32.0	3.0	101938	

EN Solid carbide planer knives  
 DE Vollhartmetall Hobelmesser  
 FR Couteaux à raboter au carbure massif  
 IT Coltelli da pialla in HM integrale  
 HU Tömörvidia gyalukések

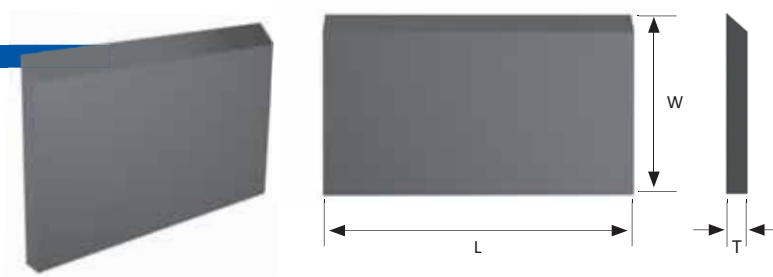

L mm	W mm	T mm	T10MG
60.0	30.0	3.0	050050
80.0	30.0	3.0	050051
100.0	30.0	3.0	042029
110.0	30.0	3.0	050053
120.0	30.0	3.0	050055
130.0	30.0	3.0	044900
150.0	30.0	3.0	042030
180.0	30.0	3.0	050057
210.0	30.0	3.0	050059
230.0	30.0	3.0	049223
240.0	30.0	3.0	106296
260.0	30.0	3.0	049222
310.0	30.0	3.0	050061

EN Only for use in special clamping systems for carbide knives, not in conventional planing heads!  
 DE Nur in Spezialklemmsystemen für Vollhartmetallhobelmesser einsetzen, nicht in herkömmlichen Hobelköpfen!  
 FR Seulement pour utilisation dans des systèmes de serrage spéciaux pour les couteaux en carbure, pas dans les têtes de rabotage conventionnelles!  
 IT Solo per l'impiego in sistemi di serraggio speciali per coltelli in metallo duro, non nella testa di piallatura convenzionale!  
 HU Csak vidia kések speciális befogó rendszerével használható, hagyományos gyalufejekben nem!

EN T.C.T. planer knives  
 DE HM-bestückte Hobelmesser  
 FR Couteaux à mise rapportée carbure  
 IT Coltelli da pialla con metallo duro riportato  
 HU Vídiabetés gyalukések

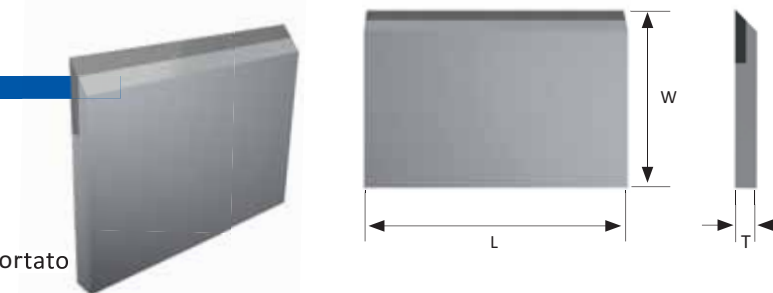



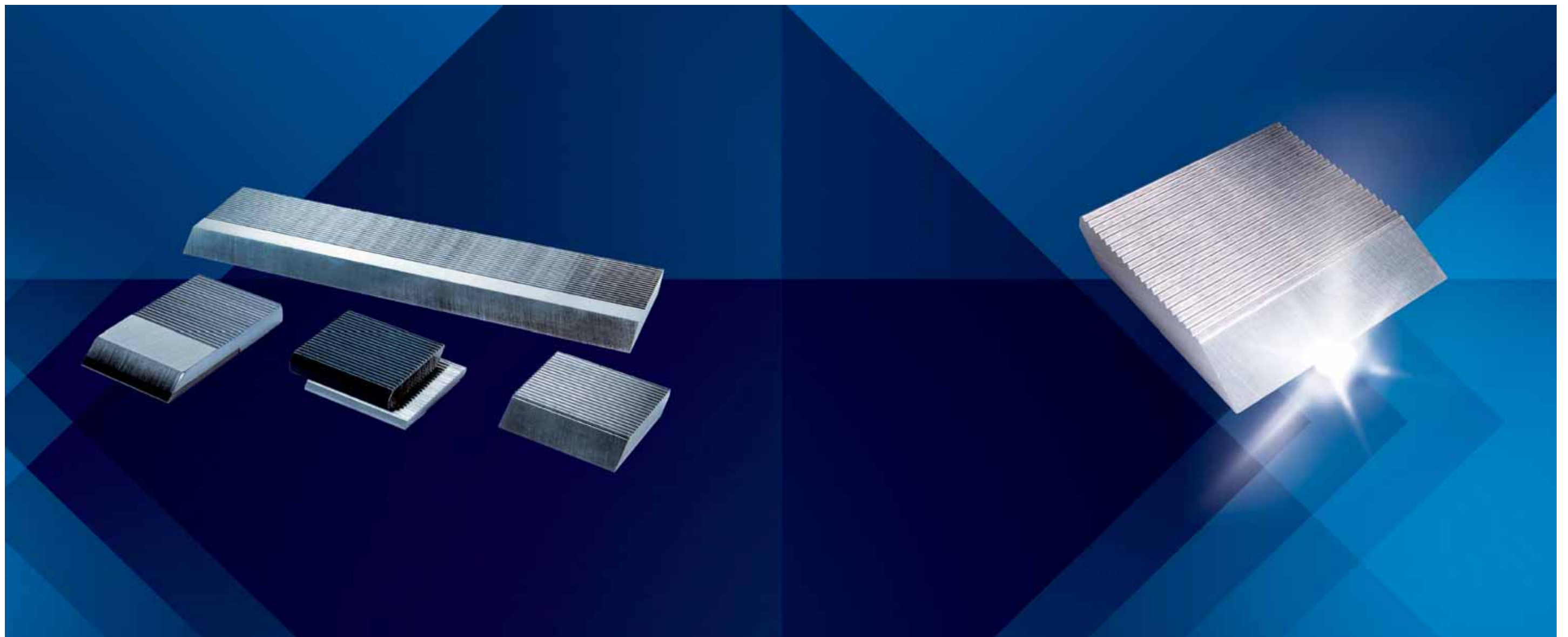



L mm	T mm	W = 25 mm	W = 30 mm	W = 35 mm
60.0	3.0	114850	029969	030021
80.0	3.0	114851	029970	030022
100.0	3.0	113770	029972	030024
110.0	3.0	114852	029973	030025
120.0	3.0	111723	029974	030026
130.0	3.0	103946	029975	030027
150.0	3.0	105829	029979	030029
160.0	3.0	029943	029980	030030
170.0	3.0	114853	029981	030031
180.0	3.0	105830	029982	030032
200.0	3.0	110737	029986	030034
210.0	3.0	108651	029987	030035
230.0	3.0	112774	029989	030036
240.0	3.0	114854	029991	030038
250.0	3.0	029952	029993	030039
260.0	3.0	104917	029994	030040
270.0	3.0	107022	101697	107555
300.0	3.0	112585	029996	030041
310.0	3.0	029955	029997	030042
330.0	3.0	114855	002238	055837
350.0	3.0	114856	029998	030044
400.0	3.0	029957	029999	107556
410.0	3.0	104919	030001	030047
500.0	3.0	029960	030006	030049
510.0	3.0	104920	030007	030050
520.0	3.0	109690	030009	103998
530.0	3.0		051130	030051
600.0	3.0		030011	030052
610.0	3.0		030012	030054
630.0	3.0		030013	030055
640.0	3.0		030014	030057
680.0	3.0		114849	106194
710.0	3.0		030016	030058
810.0	3.0		030018	030059
820.0	3.0		100445	100446
1010.0	3.0		030131	030137
1050.0	3.0	104830	030132	030138

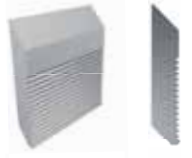

EN Knives for back corrugated cutterheads  
DE Messer für rückenverzahnte Messerköpfe  
FR Couteaux pour outils crantés  
IT Coltelli per teste con zigrinatura  
HU Kések bordáshátú késfejekhez

- EN Knives for back corrugated cutterheads  
 DE Messer für rückenverzahnte Messerköpfe  
 FR Couteaux pour outils crantés  
 IT Coltelli per teste con zigrinatura  
 HU Kések bordáshátú késfejekhez

	EN HSS / H.P.S. / Matrix blanks, back corrugated DE HSS / H.P.S. / Matrix Blanketts, rückenverzahnt FR HSS / H.P.S. / Matrix fers crantés IT HSS / H.P.S. / Matrix placchette, con zigrinatura HU HSS / H.P.S. / Matrix nyerskés, bordázott háttal	8 mm 8 mm 8 mm 8 mm 8 mm	134 - 135
	EN HSS blanks, back corrugated DE HSS Blanketts, rückenverzahnt FR HSS fers crantés IT HSS placchette, con zigrinatura HU HSS nyerskés, bordázott háttal	4-6 mm 4-6 mm 4-6 mm 4-6 mm 4-6 mm	136
	EN HSS blanks, back corrugated DE HSS Blanketts, rückenverzahnt FR HSS fers crantés IT HSS placchette, con zigrinatura HU HSSnyerskés, bordázott háttal	hüvelyk	137
	EN T.C.T. blanks, back corrugated DE HM-bestückte Blanketts, rückenverzahnt FR Fers crantés au carbure rapportée IT Placchette con metallo duro riportato, con zigrinatura HU Vídiabetés nyerskés, bordázott háttal		138 - 139
	EN SuperPac - T.C. knives and backing plates for back corrugated cutterheads DE SuperPac - HM-Messer und Stützplatten für rückenverzahnte Messerköpfe FR SuperPac - Couteaux au carbure et supports pour outils crantés IT SuperPac - Coltelli HW e supporti per teste con zigrinatura HU SuperPac - Vídia kések és nyomódúcok bordázott hátú késfejekhez		140 - 141
	EN For MicroSystem - T.C. knives and backing plates for back corrugated cutterheads DE Für MicroSystem - HM-Messer und Stützplatten für rückenverzahnte Messerköpfe FR Pour MicroSystem - Couteaux au carbure et supports pour outils crantés IT Per MicroSystem - Coltelli HW e supporti per teste con zigrinatura HU MicroSystemhez -Vídia kések és nyomódúcok bordázott hátú késfejekhez		142



EN Knives for back corrugated cutterheads - Grades and their applications  
 DE Messer für rückenverzahnte Messerköpfe - Sorten und ihre Anwendungen  
 FR Couteaux pour outils crantés - Les nuances et leurs applications  
 IT Coltelli per teste con zigrinatura - I tipi e le loro applicazioni  
 HU Kések bordáshátú késfejekhez - Kategóriák és felhasználásuk

EN TIGRA grade DE TIGRA - Sorte FR Nuance TIGRA IT Tipo TIGRA HU TIGRA kategória	Compositon Zusammensetzung Composition Composizione Összetétel	Hardness Härte Dureté Durezza Keménység	Toughness Zähigkeit Ténacité Tenacità Szívósság	Bending strength Biegebruchfestigkeit Résistance à la flexion Resistenza flessionale Hajlítószilárdság	EN Plastics DE Plastik FR Plastiques IT Plastica HU Müanyag	HDF HDF HDF HDF HDF	MDF MDF MDF MDF MDF	Chipboard Spanplatte Panneaux de particule Truciolare Forgácslap	Hardwood Hartholz Bois dur Legno duro Keményfa	Softwood Weichholz Bois tendre Legno tenero Puhafa	Main usage Hauptverwendung Usage principal Usò principale Fő alkalmazási terület
HSS	HSS 6 % (M2)	↕	↕	↕	○	▣	▣	○	✓	✓	EN Universal, small and medium batches DE Universell, Klein- und Mittelserien FR Universel, séries petites et moyennes IT Universale, lotti piccoli e medi HU Univerzális, kis és közép sorozatoknál
H.P.S.	CrV	↕	↕	↕	▣	▣	▣	▣	○	✓	EN Softwood, low price demands DE Weichholz, preisgünstig FR Bois tendre, prix bas IT Legni teneri, costo basso HU Puhafához, alacsony árúknál
T.C.T.	vídiáfogas	↔	↔	↔	✓	○	○	✓	✓	✓	EN Higher lifetime demands, wood, MDF DE Hohe Standzeitanforderungen, Holz, MDF FR Applications de durabilité, bois, MDF IT Elevata esigenza di durata, legno, MDF HU Hosszabb él(et)tartamigénynél, fához, MDF-hez
Wolfram karbid	különféle fajták	↕	↔	↔	✓	✓	✓	✓	✓	✓	EN Highest lifetime demands, multiple resharpening DE Höchste Standzeitanforderungen, mehrfaches Nachschärfen FR Applications de durabilité maximisée et nombreux affûtages IT Massima esigenza di durata, affilatura multipla HU Nagyon hosszú él(et)tartamigénynél, többször élezhető
Matrix	HSS speciális bevonattal	↔	↔	↔	○	▣	▣	▣	✓	✓	EN Long lifetime in wood, good resharpening DE Lange Standwege in Holz, gut zum Nachschärfen FR Longue durée de vie en bois, affûtage facile IT Durata lunga in legno, buona affilatura HU Hosszú él(et)tartam fában, jól újraélezhetőség

✓ kiváló teljesítőképesség  
 ↕ nagyon jó teljesítményű  
 ○ elfogadható  
 ▣ - nem alkalmas

EN For technical data, please refer to the pages 8-9.  
 DE Die technischen Daten entnehmen Sie bitte den Seiten 8-9.  
 FR Pour les données techniques, veuillez voir aux pages 8-9.

IT Per i dati tecnici, fare riferimento alle pagine 8-9.  
 HU A műszaki adatokat a 8-9. oldalon találja.

EN Back corrugated blanks  
 DE Rückenverzahnte Blanketts  
 FR Fers crantés  
 IT Placchette con zigrinatura  
 HU Bordáshátú nyerskések

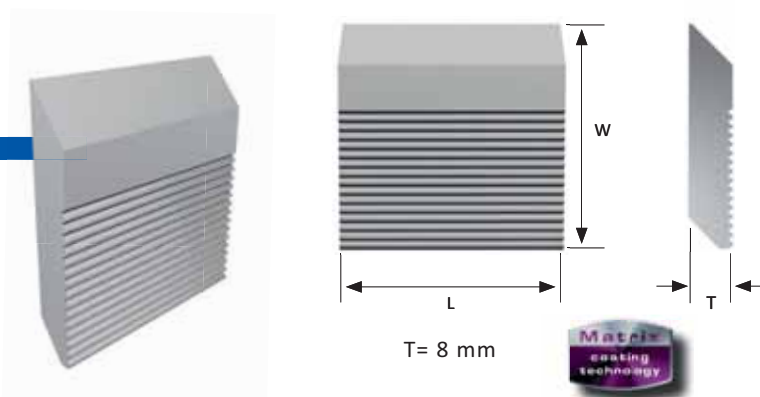

L mm	W mm	T mm	HSS 6 % (M2)	H.P.S.	Matrix bevonat- technológia
40	40	8.0	030289	103456	120287
50	40	8.0	030290	103457	120269
60	40	8.0	030291	103458	120270
70	40	8.0	030292	103459	120271
80	40	8.0	030293	103460	120272
100	40	8.0	030295	103462	120274
130	40	8.0	030297	103465	120277
150	40	8.0	030298	103466	120278
170	40	8.0	030299	103467	120279
180	40	8.0	030300	103468	120280
200	40	8.0	030301	103469	120281
210	40	8.0	030302	103470	120282
260	40	8.0	030304	103472	120284
650	40	8.0	030306	103473	120285
40	50	8.0	030307	103474	120288
50	50	8.0	030308	103475	120289
60	50	8.0	030309	103476	120290
70	50	8.0	030310	103477	120291
80	50	8.0	030311	103478	120292
90	50	8.0	030312	103479	120293
100	50	8.0	030313	103480	120294
110	50	8.0	047398	103481	120295
120	50	8.0	030314	103482	120296
130	50	8.0	030315	103483	120297
150	50	8.0	030316	103484	120298
170	50	8.0	030317	103485	120299
180	50	8.0	030318	103486	120300
200	50	8.0	030319	103488	120301
210	50	8.0	030320	103489	120302
230	50	8.0	030321	103490	120303
260	50	8.0	030322	103491	120304
650	50	8.0	030324	103492	120305

EN Back corrugated blanks  
 DE Rückenverzahnte Blanketts  
 FR Fers crantés  
 IT Placchette con zigrinatura  
 HU Bordáshátú nyerskések

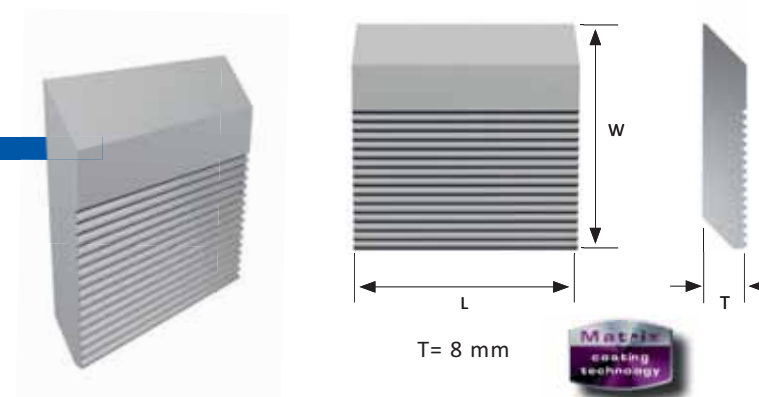

L mm	W mm	T mm	HSS 6 % (M2)	H.P.S.	Matrix bevonat- technológia
40	60	8.0	030326	103493	120310
50	60	8.0	030327	103494	120311
60	60	8.0	030328	103495	120312
70	60	8.0	030329	103496	120313
80	60	8.0	030330	103497	120314
90	60	8.0	030331	103498	120315
100	60	8.0	030332	103499	120316
110	60	8.0	047399	103500	120317
120	60	8.0	030333	103501	120318
130	60	8.0	030334	103502	120319
150	60	8.0	030335	103503	120320
170	60	8.0	030336	103504	120321
180	60	8.0	030337	103505	120322
200	60	8.0	030338	103506	120323
210	60	8.0	030339	103507	120324
230	60	8.0	030340	103508	120325
650	60	8.0	030344	103510	120327
40	70	8.0	030345	103511	120328
50	70	8.0	030346	103512	120329
60	70	8.0	030347	103513	120330
70	70	8.0	030348	103514	120331
80	70	8.0	030349	103515	120332
90	70	8.0	030350	103516	120333
100	70	8.0	030351	103517	120334
110	70	8.0	047400	103518	120335
120	70	8.0	030352	103519	120336
130	70	8.0	030353	103521	120337
150	70	8.0	030354	103522	120338
170	70	8.0	030355	103523	120339
180	70	8.0	030356	103524	120340
200	70	8.0	030357	103525	120341
210	70	8.0	030358	103526	120342
230	70	8.0	030359	103527	120343
650	70	8.0	030362	103529	120345

EN Back corrugated blanks  
 DE Rückenverzahnte Blanketts  
 FR Fers crantés  
 IT Placchette con zigrinatura  
 HU Bordáshátú nyerskések

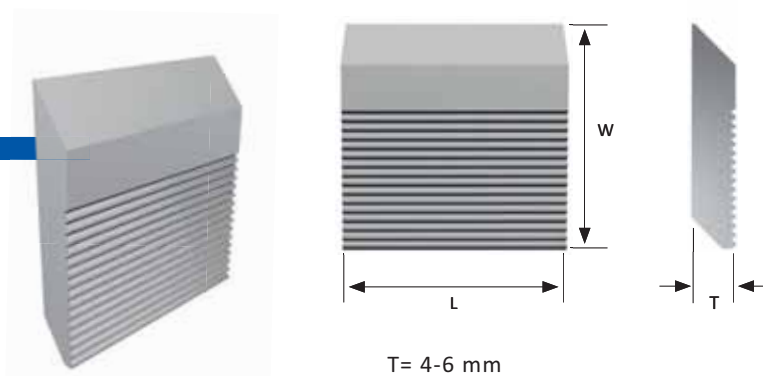

L mm	W mm	T mm	HSS 6% (M2)
650	30	4.0	104735
650	27	5.0	108483
650	38	5.0	108522
650	45	5.0	108562
650	50	5.0	108604
650	40	6.0	051029
650	45	6.0	122083
650	50	6.0	043807
650	60	6.0	043808

EN Back corrugated blanks  
 DE Rückenverzahnte Blanketts  
 FR Fers crantés  
 IT Placchette con zigrinatura  
 HU Bordáshátú nyerskések

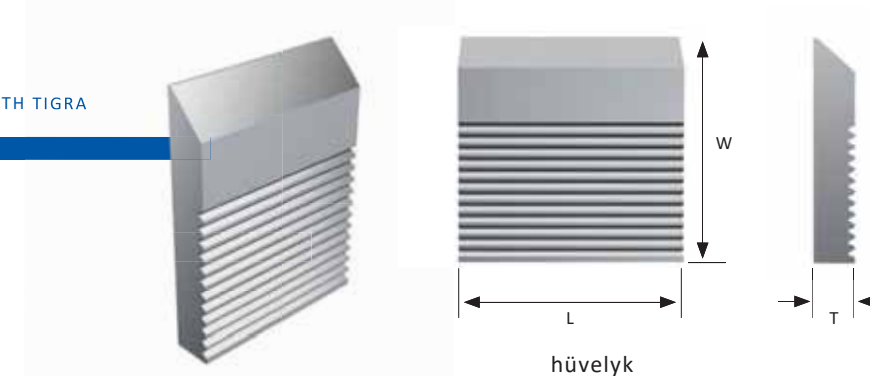

L inch	W inch	T inch	HSS 6% (M2)
25	1 1/4	5/16	101054
25	1 1/2	5/16	101055
25	1 3/4	5/16	101056
25	2	5/16	101057
25	2 1/4	5/16	101058
25	2 1/2	5/16	101059
25	2 3/4	5/16	101060
25	3	5/16	101061
25	1 1/4	1/4	101062
25	1 1/2	1/4	101063
25	1 3/4	1/4	101064
25	2	1/4	101065
25	2 1/4	1/4	101066
25	2 1/2	1/4	101067
25	1 3/4	3/16	101068
25	2	3/16	101069

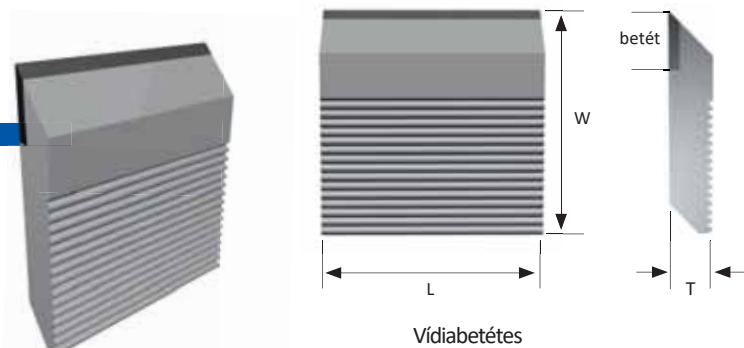

EN Back corrugated blanks  
 DE Rückenverzahnte Blanketts  
 FR Fers crantés  
 IT Placchette con zigrinatura  
 HU Bordáshátú nyerskések

L mm	W mm	T mm	Betét 14 mm	Betét 20 mm	Betét 25 mm	Betét 30 mm	Betét 35 mm
650	40	8.0	165719	167153			
650	50	8.0		104570	103363		
650	60	8.0	104335	104336	104337	102546	128589
650	70	8.0				111854	165721

L mm	W mm	T mm	Betét 20 mm	Betét 25 mm
40	40	10.0	103249	
60	40	10.0	103250	
80	40	10.0	103251	
130	40	10.0	103253	
150	40	10.0	103254	
180	40	10.0	103255	
200	40	10.0	103256	
310	40	10.0	103259	
650	40	10.0	101746	
40	50	10.0	030254	
60	50	10.0	103261	
80	50	10.0	103262	
100	50	10.0	103263	
130	50	10.0	103264	
150	50	10.0	103265	
200	50	10.0	103267	
230	50	10.0	103268	
650	50	10.0	030264	105661

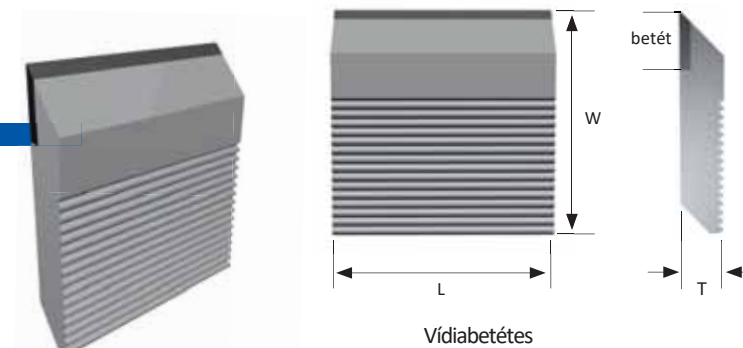

EN Back corrugated blanks  
 DE Rückenverzahnte Blanketts  
 FR Fers crantés  
 IT Placchette con zigrinatura  
 HU Bordáshátú nyerskések

L mm	W mm	T mm	Betét 25 mm	Betét 30 mm	Betét 35 mm
40	60	10.0	103300	114867	114868
60	60	10.0	103301	103797	109128
80	60	10.0	030269	109133	109129
100	60	10.0	030270	109134	109130
120	60	10.0	109479	114865	114866
130	60	10.0	030271	109135	109131
150	60	10.0	103302	114869	114870
180	60	10.0	103303	109136	109132
230	60	10.0	103305	109137	109138
650	60	10.0	102053	133295	133296
650	70	10.0		133297	133298



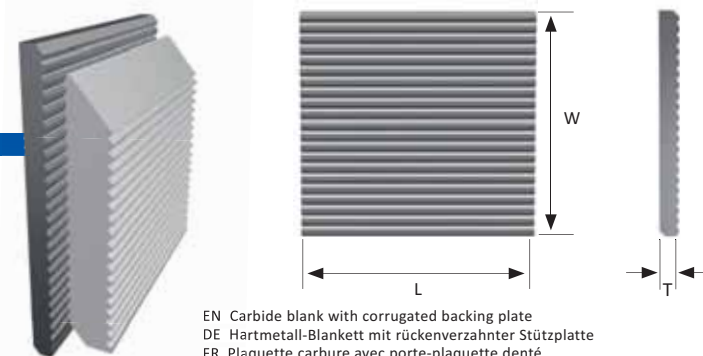

EN Carbide blank with corrugated backing plate  
 DE Hartmetall-Blankett mit rückenverzählter Stützplatte  
 FR Plaquette carbure avec porte-plaquette denté  
 IT Coltello in HM zigrinato con piastra di supporto zigrinata  
 ES Cu Vidia nyerskés bordáshátú nyomódúccal

EN TIGRA SuperPac  
 DE TIGRA SuperPac  
 FR TIGRA SuperPac  
 IT TIGRA SuperPac  
 HU TIGRA SuperPac



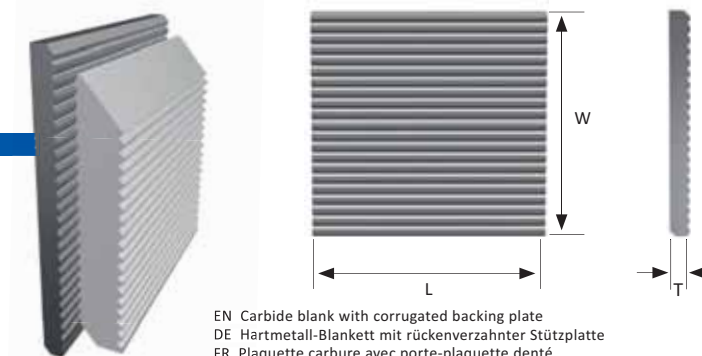

L mm	W mm	T mm	T10MG	T04F-CR	L mm	W mm	T mm	Backing plate Nyomódúc
40	38	3.2	043933	024082	40	35	7.1	024090
50	38	3.2	043934	043924	50	35	7.1	043957
60	38	3.2	043935	024115	60	35	7.1	024123
80	38	3.2	043936	024148	80	35	7.1	024156
100	38	3.2	043937	023949	100	35	7.1	023957
120	38	3.2	043938	023982	120	35	7.1	023990
130	38	3.2	043939	024016	130	35	7.1	024024
150	38	3.2	043940	024049	150	35	7.1	024057
170	38	3.2	043962	043961	170	35	7.1	045837
180	38	3.2	113497		180	35	7.1	113484
200	38	3.2	113498	131214	200	35	7.1	113485
210	38	3.2	113499	131216	210	35	7.1	113486
230	38	3.2	113500	131217	230	35	7.1	113487
310	38	3.2	113501	131219	310	35	7.1	112229
330	38	3.2	113502	131220	330	35	7.1	113481
40	50	3.2	043941	024093	40	47	7.1	024101
50	50	3.2	043942	043927	50	47	7.1	043958
60	50	3.2	043943	024126	60	47	7.1	024134
80	50	3.2	043944	024159	80	47	7.1	024167
100	50	3.2	043945	023960	100	47	7.1	023968
120	50	3.2	043946	023993	120	47	7.1	024001
130	50	3.2	043947	024027	130	47	7.1	024035
150	50	3.2	043948	024060	150	47	7.1	024068
170	50	3.2	043966	043965	170	47	7.1	045838
180	50	3.2	113503		180	47	7.1	113488
200	50	3.2	113504	131221	200	47	7.1	113489
210	50	3.2	113505	131222	210	47	7.1	113490
230	50	3.2	113506	131223	230	47	7.1	113491
310	50	3.2	113507	131224	310	47	7.1	112230
330	50	3.2	113508	129927	330	47	7.1	113482

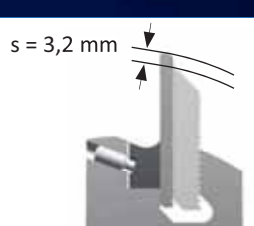

EN Carbide blank with corrugated backing plate  
 DE Hartmetall-Blankett mit rückenverzählter Stützplatte  
 FR Plaquette carbure avec porte-plaquette denté  
 IT Coltello in HM zigrinato con piastra di supporto zigrinata  
 ES Cu Vidia nyerskés bordáshátú nyomódúccal

EN TIGRA SuperPac  
 DE TIGRA SuperPac  
 FR TIGRA SuperPac  
 IT TIGRA SuperPac  
 HU TIGRA SuperPac

L mm	W mm	T mm	T10MG	T04F-CR	L mm	W mm	T mm	Backing plate Nyomódúc
40	60	3.2	043949	024104	40	57	7.1	024112
50	60	3.2	043950	043931	50	57	7.1	043959
60	60	3.2	043951	024137	60	57	7.1	024145
80	60	3.2	043952	024170	80	57	7.1	024178
100	60	3.2	043953	023971	100	57	7.1	023979
120	60	3.2	043954	024004	120	57	7.1	024012
130	60	3.2	043955	024038	130	57	7.1	024046
150	60	3.2	043956	024071	150	57	7.1	024079
170	60	3.2	043970	043969	170	57	7.1	045839
180	60	3.2	113509		180	57	7.1	113493
200	60	3.2	113510	131240	200	57	7.1	113494
210	60	3.2	113511	131241	210	57	7.1	113495
230	60	3.2	113512	131243	230	57	7.1	113496
310	60	3.2	113513	131244	310	57	7.1	112231
330	60	3.2	113514	129928	330	57	7.1	113483

	EN Security advices DE Sicherheitshinweise FR Conseils de sécurité	IT Consigli di sicurezza HU Biztonsági utasítások								
 <p>s = 3,2 mm</p>	<p>EN Cutting Edge Projection Between carbide blank and backing plate s=3,2 mm (critical dimension when regrinding).                  DE Schneidenüberstand Schneidenüberstand von Hartmetallplatte zu Stützplatte s=3,2 mm (beim Nachschärfen zu beachten).                  FR Saillie des plaquettes Les plaquettes carbure dépassent le support de 3,2 mm (à prendre en compte lors du réaffûtage).                  IT Sporgenza del tagliente Sporgenza del tagliente rispetto alla piastra di supporto s= 3,2 mm (prestare attenzione in caso di riaffilatura).                  HU Vágóél kiemelkedése A vidiakés kiemelkedése a nyomódúc felett s=3,2 mm (újraélezésnél ügyelni)..</p>									
	<p>EN Maximum Profile Depth                  DE Maximale Profiltiefe                  FR Profondeur de profil maximum                  IT Profondità massima della sagomatura                  HU Legnagyobb profilmélység</p> <table border="1"> <thead> <tr> <th>W mm</th> <th>P max mm</th> </tr> </thead> <tbody> <tr><td>38</td><td>-</td></tr> <tr><td>50</td><td>12</td></tr> <tr><td>60</td><td>23</td></tr> </tbody> </table>	W mm	P max mm	38	-	50	12	60	23	
W mm	P max mm									
38	-									
50	12									
60	23									
	<p>EN Warning! Specific positioning of blank and support plate; be aware of the safety regulations!                  DE Warnung! Sitzgenauer Einbau von Blankett und Stützplatte; Sicherheitsbestimmungen beachten!                  FR Avertissement! Positionnement précis de plaque et porte-plaquette; observez les règles de sécurité!                  IT Attenzione! Esatto montaggio in sede del coltello e della piastra di supporto; rispettare le norme di sicurezza!                  HU Vigyázat! A kés és a nyomódúc pontos beültetése; a biztonsági előírásokra ügyelni!</p>									
	<p>EN Warning! Maximum adjustment of blank = 8 mm                  DE Warnung! Maximale Verstellung des Blanketts = 8 mm                  FR Avertissement! Ajustement maximum de plaquette = 8 mm                  IT Attenzione! Regolazione massima della placchetta = 8 mm                  HU Vigyázat! A kés legnagyobb kiállíthatósága = 8 mm</p>									

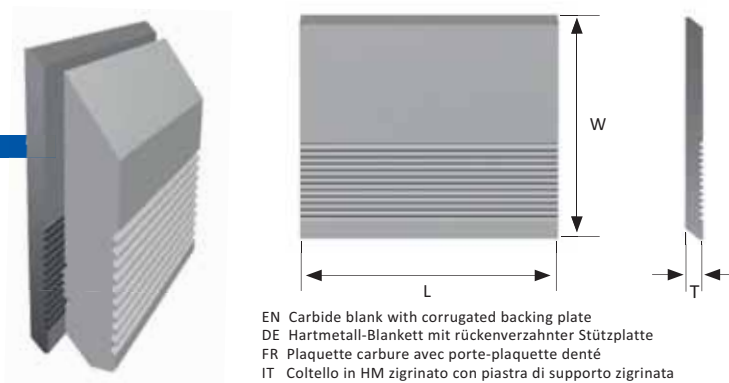

EN Carbide blank with corrugated backing plate  
 DE Hartmetall-Blankett mit rückenverzahnter Stützplatte  
 FR Plaquette carbure avec porte-plaquette denté  
 IT Coltello in HM zigrinato con piastra di supporto zigrinata  
 HU Vídia nyerskések bordáshátú nyomódúccal

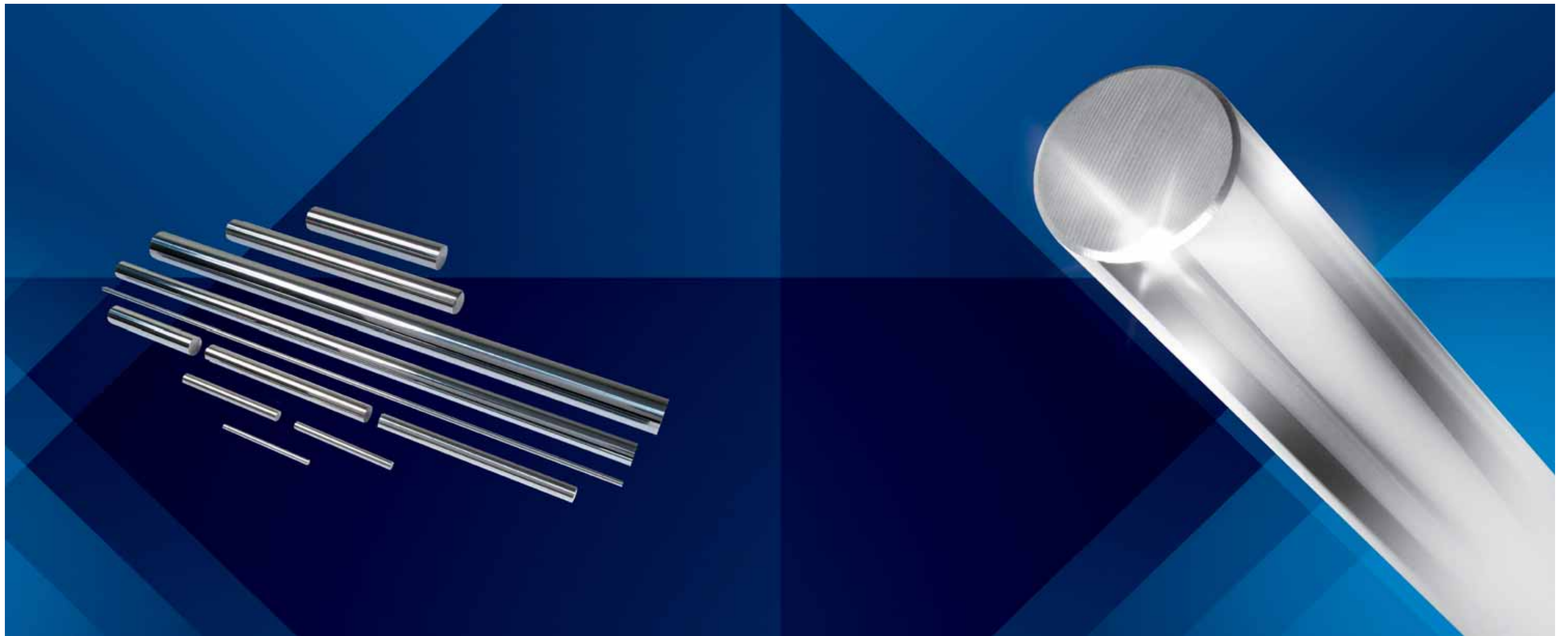

EN MicroSystem  
 DE MicroSystem  
 FR MicroSystem  
 IT MicroSystem  
 HU MicroSystem

L mm	W mm	T mm	T10MG	T04F-CR	L mm	W mm	T mm	EN Backing plate HU Nyomódúc
40	38	2.5	131966	133530	40	35	7.5	131991
60	38	2.5	131967	133531	60	35	7.5	131992
80	38	2.5	131968	133532	80	35	7.5	131993
100	38	2.5	131969	133533	100	35	7.5	131994
130	38	2.5	131970	133534	130	35	7.5	131995
150	38	2.5	131971	133535	150	35	7.5	131996
180	38	2.5	131972	133536	180	35	7.5	131997
230	38	2.5	131973	133537	230	35	7.5	131998
240	38	2.5	131974	133538	240	35	7.5	131999
40	50	2.5	131975	133539	40	47	7.5	132000
60	50	2.5	131976	133540	60	47	7.5	132001
80	50	2.5	131977	133541	80	47	7.5	132002
100	50	2.5	131978	133542	100	47	7.5	132003
130	50	2.5	131979	133543	130	47	7.5	132004
150	50	2.5	131980	133544	150	47	7.5	132005
180	50	2.5	131981	133545	180	47	7.5	132006
240	50	2.5	131982	133546	240	47	7.5	132007
40	60	2.5	131983	133547	40	57	7.5	132008
60	60	2.5	131984	133548	60	57	7.5	132009
80	60	2.5	131985	133549	80	57	7.5	132010
100	60	2.5	131986	133550	100	57	7.5	132011
130	60	2.5	131987	133551	130	57	7.5	132012
150	60	2.5	131988	133552	150	57	7.5	132013
180	60	2.5	131989	133553	180	57	7.5	132014
240	60	2.5	131990	133554	240	57	7.5	132015



EN Rods  
DE Rundstäbe  
FR Barreaux cylindriques  
IT Cilindri  
HU Rúdanyagok

EN Rods  
 DE Rundstäbe  
 FR Barreaux cylindriques  
 IT Cilindri  
 HU Rúdanyagok

	<p>EN Rods - ground            DE Rundstäbe - geschliffen            FR Barreaux cylindriques - affûtés            IT Cilindri - rettificati            HU Rúdanyagok - csiszolva</p>	<p>metric            metrisch            métrique            metrico            metrikus</p> <p>150 - 152</p>
	<p>EN Rods - ground            DE Rundstäbe - geschliffen            FR Barreaux cylindriques - affûtés            IT Cilindri - rettificati            HU Rúdanyagok - csiszolva</p>	<p>hüvelyk</p> <p>153</p>
	<p>EN TIGRAMet - Heavy alloy tool body blanks            DE TIGRAMet - Grundkörperrohlinge aus Schwermetall            FR TIGRAMet - Ébauches en métal lourd            IT TIGRAMet - Corpo utensile grezzo in metallo pesante            HU TIGRAMet -Nyers alaptestek nehézacélból</p>	<p>154</p>



EN Rods - Carbide grades and their applications  
 DE Rundstäbe - Hartmetallsorten und ihre Anwendungen  
 FR Barreaux cylindriques - Les nuances de carbures et leurs applications  
 IT Cilindri - I tipi di metallo duro e le loro applicazioni  
 HU Rúdanyagok - Vídia kategóriák és felhasználásuk

EN TIGRA grade	ISO	USA	Hardness	Toughness	Bending strength	Plastics	HDF	MDF	Chipboard	Hardwood	Softwood	Main usage
DE TIGRA - Sorte	ISO	USA	Härte	Zähigkeit	Biegebruchfestigkeit	Plastik	HDF	MDF	Spanplatte	Hartholz	Weichholz	Hauptverwendung
FR Nuance TIGRA	ISO	USA	Dureté	Ténacité	Résistance à la flexion	Plastiques	HDF	MDF	Panneaux de particule	Bois dur	Bois tendre	Usage principal
IT Tipo TIGRA	ISO	Stati uniti	Durezza	Tenacità	Resistenza flessionale	Plastica	HDF	MDF	Truciolare	Legno duro	Legno tenero	Usi principali
HU TIGRA kategória	ISO	USA	Keménység	Szívósság	Hajlítószilárdság	Műanyag	HDF	MDF	Forgácslap	Keményfa	Puhafa	Fő alkalmazási terület
T03MG-CR	K01	C4++	↑	↓	↖	○	✓	✓	✓	☒	☒	EN Highly abrasive materials, boards, larger tool diameters DE Stark abrasive Materialien, Platten, größere Werkzeugdurchmesser FR Matériaux très abrasifs, panneaux, diamètres d'outils plus grands IT Materiali altamente abrasivi, pannelli, utensili di diametro maggiore HU Nagyon koptató anyagok, panelek, nagyobb szerszámtérők
T03F-CR	K01	C4+	↑	→	↖	✓	✓	✓	✓	☒	☒	EN Highly abrasive materials, boards, larger tool diameters DE Stark abrasive Materialien, Platten, größere Werkzeugdurchmesser FR Matériaux très abrasifs, panneaux, diamètres d'outils plus grands IT Materiali altamente abrasivi, pannelli, utensili di diametro maggiore HU Nagyon koptató anyagok, panelek, nagyobb szerszámtérők
T06MG	K01 - K10	C3++	↗	→	→	✓	○	✓	✓	○	☒	EN Harder boards and woods, plastics, graphite, aluminum, larger tool diameters DE Härtere Platten und Holz, Kunststoff, Graphit, Aluminium, größere Werkzeugdurchmesser FR Panneaux durs et bois durs, plastiques, graphite, aluminium, diamètres d'outils plus grands IT Pannelli e legni più duri, plastica, grafite, alluminio, utensili di diametro maggiore HU Keményebb panelek és fák, műanyagok, grafit, alumínium, nagyobb szerszámtérők
T10MG UNIVERSAL	K10 - K40	C3+	→	↑	↖	○	○	○	○	✓	✓	EN Universal grade DE Universelle Sorte FR Nuance universelle IT Tipo universale HU Univerzális alkalmazás
T10MG-W	K10 - K40	C3+	→	↑	↖	○	○	○	○	✓	✓	EN Wood and board, lower price DE Holz und Platten, niedrigerer Preis FR Bois et planches, prix plus bas IT Legno e pannelli, prezzo più basso HU Fák és panelek, alacsonyabb árgény

CR = Co + Ni + Cr = corrosion resistant - korrosionsbeständig - anti-corrosif - inossidabile - korrózióálló

EN For technical data, please refer to the pages 4-5.  
 DE Die technischen Daten entnehmen Sie bitte den Seiten 4-5.  
 FR Pour les données techniques, veuillez voir aux pages 4-5.

IT Per i dati tecnici, fare riferimento alle pagine 4-5.  
 HU A műszaki adatokat a 4-5. oldalon találja.

✓ kiváló teljesítőképesség  
 ✓ nagyon jó teljesítmény  
 ○ elfogadható  
 ☒ - nem alkalmas

EN Rods  
 DE Rundstäbe  
 FR Barreaux cylindriques  
 IT Cilindri  
 HU Rúdanyagok

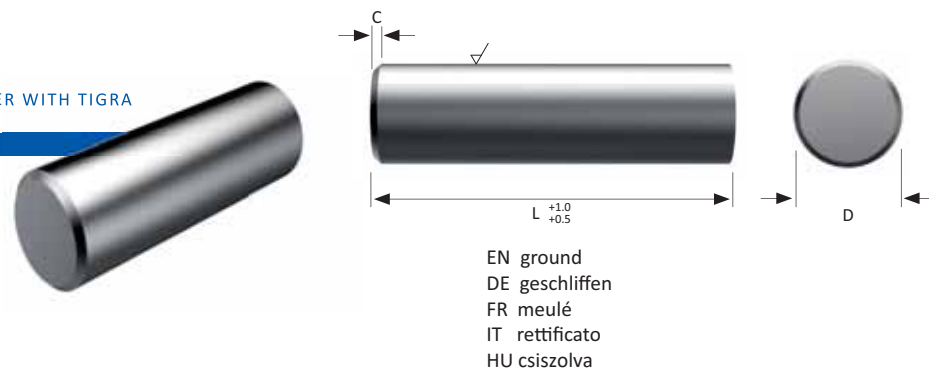

D mm	L mm	C mm	T10MG h5	T03F-CR h5	T06MG h5	T10MG-W h6
1.5	330		035518			
2.0	100 330		036368 035519			
2.5	50 100 330		049983 036370 035520			
3.0	38 43 50 330		053363 039162 034177 029708		100980 055446 055445 029707	148181 148162
3.5	330		035521			
4.0	43 50 55 330		039161 034178 039104 029710		106821 034158 101012 029709	148206 148163
5.0	43 50 330		052459 034179 034802	114920 114921 114912	106780 034159 036541	151498 148164
5.5	330		035523			
6.0	46 50 55 60 70 330	0.4 0.4 0.4 0.4	102374 043244 039107 034180 043527 029712	114922 114923 114924 114925 114926 114913	106785 106787 101016 034160 106399 029711	148182 148183 148184 148185 148165
6.5	330		035524			
7.0	330		035525		036544	148166
7.5	330		035526			
8.0	50 55 56 60 70 75 80 100 330	0.6 0.6 0.6 0.6 0.6 0.6 0.6 0.6	045419 041602 102197 046522 038349 041481 034181 036392 029714	114941 114942 114943 114944 114945 114946 114947 114948 114928	106788 106789 106790 102018 101017 101018 034161 036391 029713	148186 148187 148188 148208 148167
8.5	330		035527			
9.0	330		035528			148168
9.5	330		035529			

EN Rods  
 DE Rundstäbe  
 FR Barreaux cylindriques  
 IT Cilindri  
 HU Rúdanyagok

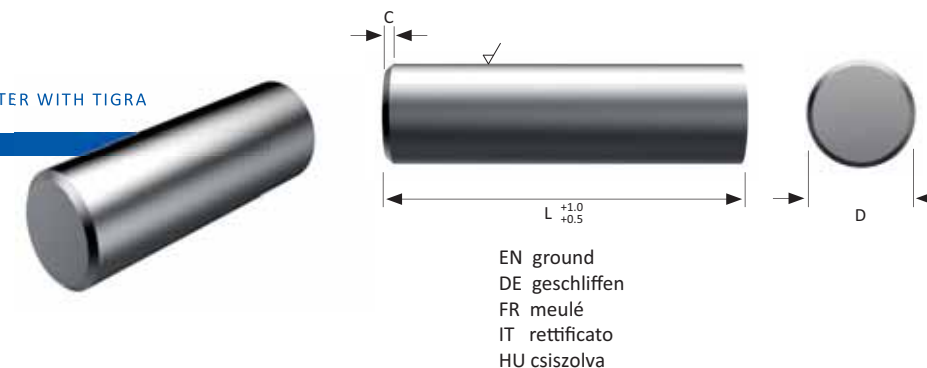

D mm	L mm	C mm	T10MG h5	T03F-CR h5	T06MG h5	T10MG-W h6
10.0	65 70 75 80 90 100 110 330	0.6 0.6 0.6 0.6 0.6 0.6 0.6	102514 038350 038351 034182 052421 034183 111134 029716	114951 114953 114954 114955 114956 114957 114929	106791 101019 055813 106402 106792 036399 029715	148194 148196 148189 148197 148193 148169
11.0	330		035531			148170
12.0	80 90 100 110 120 155 330	0.8 0.8 0.8 0.8 0.8 0.8	034184 038352 034185 052744 051331 106797 029718	114958 114959 114960 114961 114962 114963 114930	053694 101020 034165 106794 106795 106796 029717	148190 148191 148195 148171
13.0	330		035534			
14.0	90 100 110 120 330	0.8 0.8 0.8 0.8	041482 034186 038353 053659 029720	114964 114965 114966 114967 114931	101022 034166 101023 106801 029719	148198 148172
15.0	330		035537			148173
16.0	80 90 93 100 110 120 130 140 150 155 170 175 180 330	0.8 0.8 0.8 0.8 0.8 0.8 0.8 0.8 0.8 0.8 0.8 0.8 0.8	052553 038354 106803 034187 038355 034188 053858 038356 043662 041603 052410 053515 111133 029722	114972 114973 114974 114975 114976 114977 114978 114979 114980 114981 114982 114983	106412 101024 106802 034167 101025 034168 106805 101026 103951 106806 106807 106808	148202 148199 148200 148201 151499 151702
17.0	330		035540			
18.0	93 100 110 115 120 330	0.8 0.8 0.8 0.8 0.8	106809 034189 102817 038357 034190 029724	114984 114985 114986 114987 114988 114933	106810 034169 106811 101027 034170 029723	148175

EN Rods  
 DE Rundstäbe  
 FR Barreaux cylindriques  
 IT Cilindri  
 HU Rúdanyagok

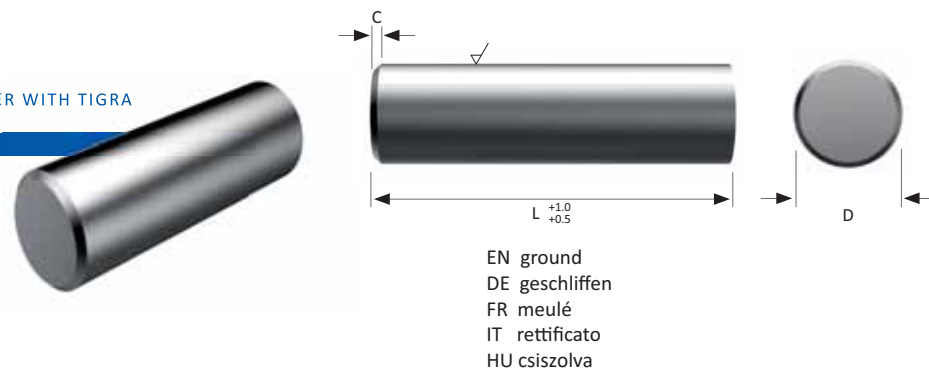

D mm	L mm	C mm	T10MG h5	T03F-CR h5	T06MG h5	T10MG-W h6	
19.0	330		035541				
20.0	100	1.0	034192	114989	034172	148203	
	110	1.0	044472	114990	106403	151500	
	115	1.0	038358	114991	101028		
	120	1.0	034193	114992	034173	148204	
	125	1.0	100241	114993	106812		
	130	1.0	106044	114994	106813	148192	
	135	1.0	039115	114995	054819	148205	
	140	1.0	038359	114996	101029		
	150	1.0	034194	114998	034174		
	155	1.0	100073	114999	106815		
	170	1.0	055570	115000	106816		
	330			029726	114934	029725	148176
	21.0	330		035542			
22.0	330		035543	114935	036562	148177	
23.0	330		035544				
24.0	330		035545				
25.0	110	1.0	102424	115005	104306		
	125	1.0	106818	115006	106817		
	155	1.0	102765	115007	106819		
	330		029728	114936	029727	148178	
26.0	330		035546				
27.0	330		036587				
28.0	330		035547				
30.0	330		035548	114938	036567	148179	
32.0	330		035549	114939	036568	148180	
35.0	330		035552	114940	036569		

EN Rods  
 DE Rundstäbe  
 FR Barreaux cylindriques  
 IT Cilindri  
 HU Rúdanyagok

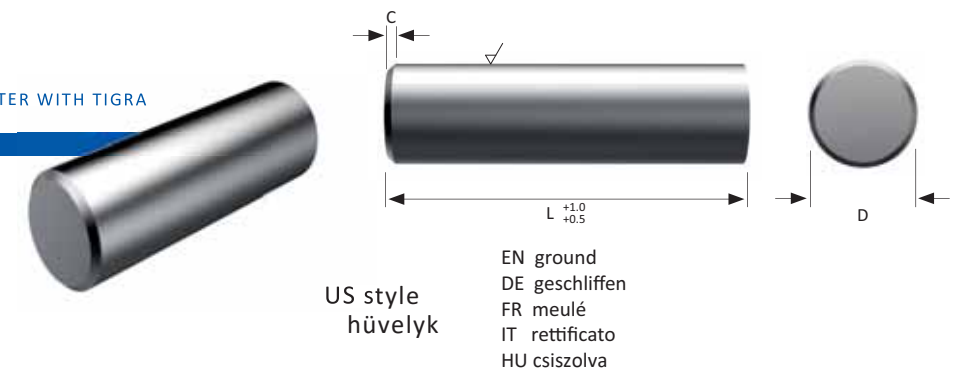

Dia inch	L inch	T10MG h5	T03F-CR h5	T06MG h5	T10MG-W h6
1/8	1 1/2	049465	115022	054851	
	2	049466	115023	054852	
	2 1/2	049467	115024	054853	
	3	050160	115025	054854	
	4	049632	115026	054855	
	6	049469	115027	054856	
	12 1/4	050139	115008	054926	150304
	5/32	3 12 1/4	049470 050140	115052 115009	054857 054927
3/16	1 1/2	049471	115028	054858	
	2	049472	115029	054859	
	2 1/2	050165	115030	054860	
	3	100251			
	12 1/4	050147	115010	054929	
7/32	12 1/4	050148	115011	054930	
15/64	12 1/4	050149	115012	054931	
1/4	1 1/2	049474	115031	054873	
	2	049475	115032	054861	
	2 1/2	049476	115033	053113	
	3	050169	115034	053114	150306
	12 1/4	050170 050150	115035 115013	054862 054821	150305
5/16	2 1/2	054350			
	3 1/2	100287			
	4	100646			
	12 1/4	050151	115014	054933	
3/8	2 1/2	049477	115036	054863	
	3	049478	115037	053115	150307
	4	049633	115038	054864	
	6	049480	115039	054865	
	12 1/4	050152	115015	054934	150311
7/16	3	101122			
	6	101668			
	12 1/4	050153	115016	054935	

Dia inch	L inch	T10MG h5	T03F-CR h5	T06MG h5	T10MG-W h6
1/2	2	050175	115040	054866	
	2 1/2	050176	115041	054867	
	3	049481	115042	053116	150309
	3 1/2	045137	115043	053117	150308
	4	049482	115044	054868	
	6	101183			
	12 1/4	050154	115017	054936	150310
	9/16	12 1/4	050155	115018	054937
5/8	3	049483	115045	054869	
	3 1/2	050180	115046	054870	
	4	049484	115047	053118	
	12 1/4	050182 050156	115048 115019	054871 054939	
3/4	4	050183	115049	053119	
	5	054148			
	6	055232			
	12 1/4	050157	115020	054822	
1	5	050184	115050	054872	
	6	100224			
	12 1/4	050158	115021	054824	

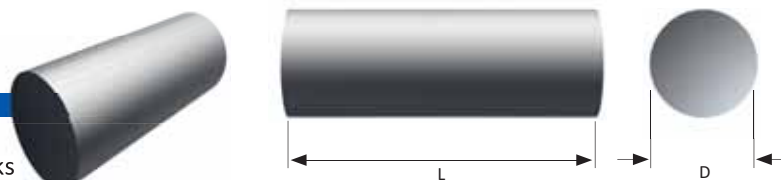

EN TIGRAMet - Heavy alloy tool body blanks  
 DE TIGRAMet - Grundkörperrohlinge aus Schwermetall  
 FR TIGRAMet - Ébauches en métal lourd  
 IT TIGRAMet - Corpo utensile grezzo in metallo pesante  
 HU TIGRAMet - Nyers alaptestek nehézacélból

D mm	L mm	TIGRAMet
6.2	270	141103
8.2	270	132113
10.2	270	131337
12.2	85	135487
12.2	370	131338
13.2	370	131339
14.2	370	131340
15.2	370	131341
16.7	155	135488
16.7	270	131342
16.7	317	131343
16.7	370	131344
18.3	270	131345
20.2	105	135489
20.2	650	131346
21.2	650	131347
22.2	380	148968
22.2	650	131348
25.2	650	135163
27.2	650	134373
40.2	650	159628

EN Technical data DE Technische Daten	FR Caractéristiques techniques IT Dati tecnici	HU Műszaki adatok
EN Density DE Dichte FR Densité IT Densità HU Sűrűség	17.1 g/cm <sup>3</sup>	0.62 lb/in <sup>3</sup>
EN Tungsten content DE Wolframgehalt FR Teneur en tungstène IT Contenuto di tungsteno HU Wolfram tartalom	90%	90%
EN Binder DE Binder FR Liant IT Legante HU Kötőanyag	Fe, Ni	Fe, Ni
EN Modulus of elasticity DE Elastizitätsmodul FR Module d'élasticité IT Modulo di elasticità HU Rugalmassági modulus	330 GPa	48 (10 <sup>3</sup> ) ksi
EN Hardness DE Härte FR Dureté IT Durezza HU Keménység	310 HV	31 HRC
EN Ultimate tensile strength DE Zugfestigkeit FR Résistance à la traction IT Resistenza di trazione HU Szakítószilárdság	875 MPa	127 ksi

EN Other dimensions upon request.  
DE Andere Abmessungen auf Anfrage.

FR D'autres dimensions sur demande.  
IT Altre dimensioni su richiesta.



HU Eltérő méretek igény szerint.

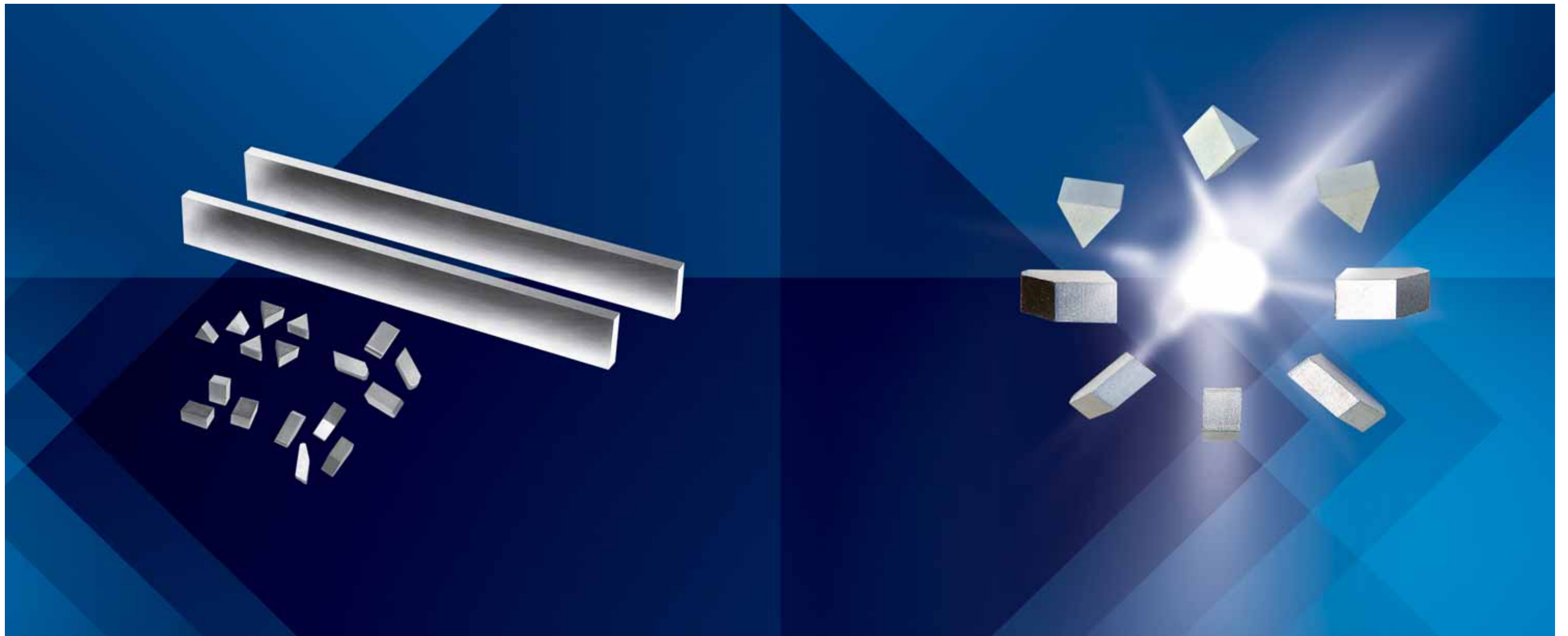

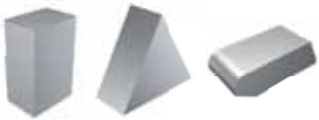

EN TIGRAAlloy products  
DE TIGRAAlloy Produkte  
FR Produits TIGRAAlloy  
IT Prodotti TIGRAAlloy  
HU TIGRAAlloy termékek

- EN TIGRALloy products
- DE TIGRALloy Produkte
- FR Produits TIGRALloy
- IT Prodotti TIGRALloy
- HU TIGRALloy termékek

	<p>EN Technical data and application recommendations          DE Technische Daten und Anwendungsempfehlungen          FR Caractéristiques techniques et recommandations d'application          IT Dati tecnici e suggerimenti di impiego          HU Műszaki adatok és alkalmazási javaslatok</p>	<p>160 - 161</p>
	<p>EN TIGRALloy - Saw tips          DE TIGRALloy - Sägezähne          FR TIGRALloy - Dents de scie          IT TIGRALloy - Dentelli per lame          HU TIGRALloy - Fűrészfogak</p>	<p>162 - 164</p>
	<p>EN TIGRALloy - Strips for brazed cutters          DE TIGRALloy - Fräserplatten zum Löten          FR TIGRALloy - Plaquettes à braser          IT TIGRALloy - Placchette per frese saldobrasate          HU TIGRALloy - Vágólapok forrasztottlapkás marókhoz</p>	<p>165</p>

## EN TECHNICAL DATA AND APPLICATION RECOMMENDATIONS

(for more information please see our TIGRALloy brochure and our technical guidebook "Carbide for cutting tools")

TIGRALloy, an alloy which mainly consists of cobalt, chromium and tungsten, takes a special position within the cutting materials being neither tungsten carbide nor HSS.

Even though its hardness is rather low, TIGRALloy can achieve multiple lifetimes of tungsten carbide in many applications because its wear pattern is completely different. In addition, TIGRALloy is extremely corrosion resistant, tough and heat resistant up to around 800°C / 1500°F. The high bending strength and material composition allow steep angles and very sharp cutting edges which reduces cutting pressure and can achieve excellent surface qualities. TIGRALloy is made by powder metallurgy and thus, compared to similar, cast materials 100% void-free.

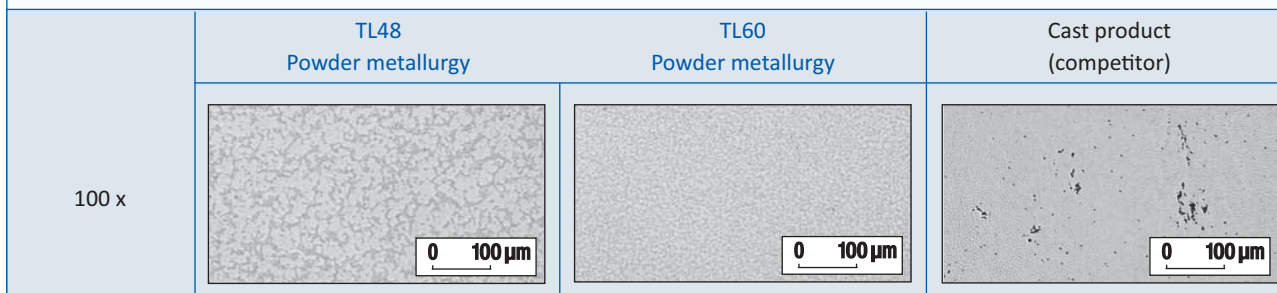

Fig. 1: Homogeneous, void-free TIGRALloy made by powder metallurgy compared to a similarly alloyed but cast product.

2 grades are offered:

TL48 (hardness 48 HRC), especially as saw tips for processing green lumber. Here, the high toughness is used to make TL48 the ideal cutting material for circular, band- and gang saws for the saw mill industry. Available in shapes of triangles, rectangles and typical saw tip shapes.

TL60 (hardness 60 HRC) for indexable inserts, blanks for profiling, planer knives, back corrugated knives and STBs for brazed tools: perfect surface qualities and excellent lifetime in the described types of wood (without gluelines), compare to Fig. 2. In addition, weight of the blades is reduced by around 40%.

TIGRALloy provides decisive advantages in most solid woods:

- Tool life: in many types of wood tool life is increased substantially compared to tungsten carbide, especially in hardwoods.
- Excellent surface quality: The high bending strength and the composition of the material allow very sharp cutting edges, which reduce the cutting pressure.
- Increased productivity as TIGRALloy makes possible to run in greater feed rates and revolution speeds.
- Secure processing: TIGRALloy is required to 100% free of macropores, thus no multiple production due to porosity.

TL48 - for circular saw blades and band saws

recommended:

nearly all kinds of raw woods, frozen wood  
recycling of wood with impurities (e.g. pellets)

not recommended:

board materials, glued-up wood  
extremely abrasive or resinified woods

TL60 - for planers, indexable inserts and brazed profiling tools

recommended:

Abachi	Incense cedar	Pine
Afromosia	Larch	Plane
Afzelia (min. 12% humidity)	Limba	Poplar
Alder	Mahogany (American red)	Ramin
Ash	Makoré	Redwood
Avodiré	Maple (European)	Sapele
Beech (min. 12% humidity)	Mengkulang	Sipo
Birch (European)	Meranti	Sugar pine
Cedar (Western Red)	Oak (American Red)	Tasmanian Oak
Cedar	Oak (European)	Tola branca
Cherry	Oak (Japanese)	Walnut
Chestnut (cultivated)	Okan	Willow
Elm	Okoumé	
Fir	Oregon pine	
Framiré	Parana pine	
Hemlock	Pear	

not recommended:

board materials, glued-up wood, extremely abrasive or resinified woods	
Afzelia (dry)	Mukulungu
Azobé	Muninga
Balau	Oak American white
Beech (dry)	Ogea
Boxwood	Padouk
Bubinga	Panga Panga
Hickory	Purpleheart
Hornbeam	Red kabbes
Keruing	Rosewood Rio
Lignum vitae	Saligna gum
Maple American	Tali
Merbau	Teak
Movingui	Wengé

Fig.: Application recommendations for both TIGRALloy grades

## HU MŰSZAKI ADATOK ÉS ALKALMAZÁSI JAVASLATOK

(További információkat TIGRALLOY prospektusunkban és "Keménységű vágószerszámokhoz" műszaki tanácsadónkban talál)

A főként kobaltból, krómból és wolframból álló TIGRALLOY ötvözet különleges helyzetet foglal el a vágóanyagok között: se nem vídía, se nem gyorsacél (HSS).

Csekély keménysége ellenére a TIGRALLOY sok alkalmazásnál jelentősen hosszabb él(et)tartamot ér el a vidiánál. Ez teljesen eltérő kopási tulajdonságai miatt van, amelyik összetétele következtében áll elő. Ezen felül a TIGRALLOY rendkívül korrózióálló, törésálló és 800°C-ig hőálló. A nagy hajlításierőssége és anyagösszetétel éles szögeket és igen éles vágóéleket enged meg, ami csökkenti a vágónyomást és és gyakorta kiemelkedő felületminőséget eredményez. A TIGRALLOY-t porkohászati úton állítják elő és emiatt, ellentétben a hasonló öntött anyagokkal, 100%-ban mentes a makropórusoktól (ld. 1. ábra).

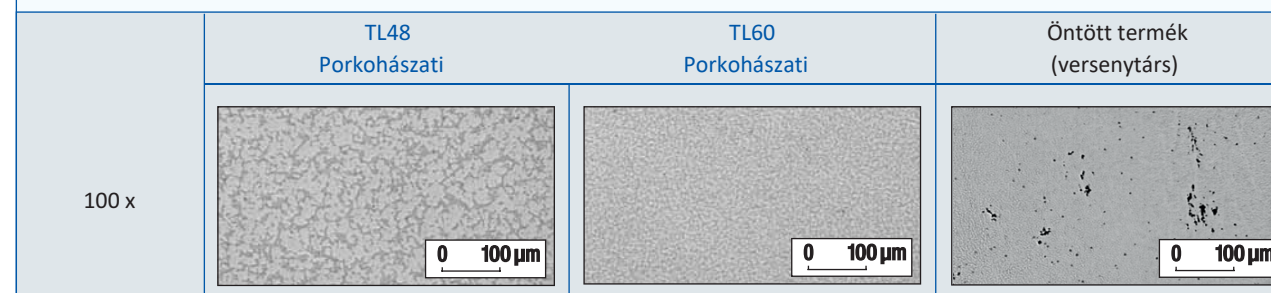

1. ábra: Porkohászati úton előállított homogén, makropórusmentes TIGRALLOY hasonló ötvözt, de öntött termékhez képest

2 fajta van az ajánlatban:

TL48 (48 HRC keménység), különösen fűrészfogakként nyersfa feldolgozáshoz. Itt a szívósság teljes mértékben kihasznál, ami a TL48-ast ideális vágóanyaggá teszi a kör-, blokk- és gatterfűrészekhez a fűrészüzemekben. Rendelkezésre áll háromszög, négyyszög formában és a tipikus vídía foggeometriákkal.

TL60 (60 HRC keménység) váltólapkákhoz, profilozható nyerslapkákhoz, gyalukésekhez, bordáshátú késekhez és forrasztott lapkákhoz: tökéletes felületminőség és igen jó él(et)tartam a felsorolt (kemény ragasztó fugák nélküli) fafajtáknál. Ezen felül a vágásnál mintegy 40%-os súlymegtakarítást ér el.

A TIGRALloy meghatározó előnyöket ajánl a legtöbb tömörfánál:

- Szerszámtartam: sok fafajtánál a szerszámtartam a vidiával összehasonlítva, különösen keményfánál, jelentősen magasabb.
- Kiváló felületminőség: A magas hajlításierőssége és az anyagösszetétel igen éles vágóéleket tesz lehetővé, amelyek a vágónyomást lecsökkentik.
- Megnövelt termelékenység, mivel a TIGRALLOY nagyobb előtolásokat és fordulatszámokat enged meg.
- Biztonságos megmunkálás: a TIGRALLOY 100%-ban makropórus mentes, így nincs megismétlődő gyártás porozitás miatt.

TL48 - körfűrészekhez és szalagfűrészekhez

ajánlott:

majd minden nyers fafajta, megfagyott fához  
Szöges fák (pl. raklapok) újra hasznosítása

nem ajánlott:

Ragasztott fák, lapanyagok  
nagyon koptató trópusi fák

TL60 - gyaluláshoz, beforrasztott és cserelapok profilos szerszámokhoz

ajánlott:

Abachi	Framiré	Ramin
Afromosia	Hemlock - fenyő	Redwood - vörösf.
Afzelia (min. 12% nedvesség)	Kasztanie (szelídgesztenye)	Sapelli
Ahorn	Kiefer - erdei fenyő	Sipo
Avodiré	Kirschbaum - cseresznye	Sugar pine- cukorf.
Birke - nyírfa (európai)	Lärche	Tanne - fenyő
Birnbaum - körtefa	Limba	Tasman tölgy
Bleistiftzeder (kaliforniai)	Macoré - amerikai körtefa	Tola
Bubinga	Mahagonie	Ulme - szilfa
Brasíliakeifer - erdei fenyő	Mengkulang	Weide - fűzfa
Buche (min 12%nedvesség)	Meranti	Zeder (nyug. vörös)
Douglászfenyő (amerikai)	Nussbaum - diófa	Zeder - cédrus
Eiche - tölgy (európai)	Okan	
Eiche - tölgy (japán)	Okoumé - balzsamfa	
Eiche - tölgy (vörös)	Pappel - nyárfa	
Erle - égerfa	Platane - hegyi juhar	
Esche- körisfa		

nem ajánlott:

Ragasztott fák, lapanyagok Nagyon koptató trópusi fák	
Afzelia (száraz)	Merbau
Ahorn - juhar (amerikai)	Movingui
Amarant - amarantusfa	Mukulungu
Azobé	Muninga
Balau - teakfa	Padouk
Bubinga	Palisander (Rio)
Buche - bükk (száraz)	Panga Panga
Buche - bükk (fehér)	Pockholz - pokkfa
Buchsbaum - puszpángfa	Sidney blue gum
Daniella	Sucupira
Eiche (amerikai fehér tölgy)	Tali
Hickory - hikorifa	Teak-tikfa
Keruing	Wengé

Ábra.: Alkalmazási javaslatok mindkét TIGRALLOY-fajtára

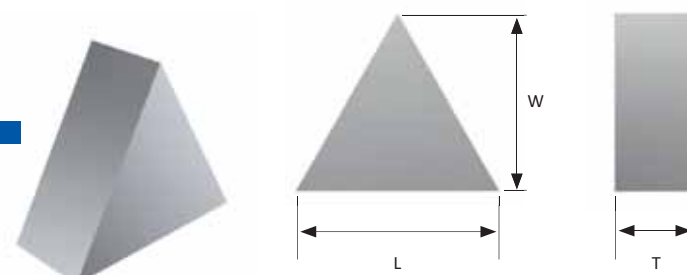

EN TIGRALloy - Saw tips  
 DE TIGRALloy - Sägezähne  
 FR TIGRALloy - Dents de scie  
 IT TIGRALloy - Dentelli per lame  
 HU TIGRALloy - Fűrészfogak

### 60°-os háromszög - hüvelyk

60T.180	L		W		T/vágásrés		TL48
	hüvelyk	mm	hüvelyk	mm	hüvelyk	mm	
.084	0.18	4.572	0.156	4.0	0.084	2.1	139103
.103	0.18	4.572	0.156	4.0	0.103	2.6	139102
.105	0.18	4.572	0.156	4.0	0.105	2.7	139101
.110	0.18	4.572	0.156	4.0	0.110	2.8	138577
.120	0.18	4.572	0.156	4.0	0.120	3.0	138582
.130	0.18	4.572	0.156	4.0	0.130	3.3	138583
.140	0.18	4.572	0.156	4.0	0.140	3.6	138584
.150	0.18	4.572	0.156	4.0	0.150	3.8	138585
.160	0.18	4.572	0.156	4.0	0.160	4.1	138586
.170	0.18	4.572	0.156	4.0	0.170	4.3	138588
.180	0.18	4.572	0.156	4.0	0.180	4.6	141545
.190	0.18	4.572	0.156	4.0	0.190	4.8	141546

60T.250	L		W		T/vágásrés		TL48
	hüvelyk	mm	hüvelyk	mm	hüvelyk	mm	
.110	0.25	6.35	0.217	5.5	0.110	2.8	132644
.120	0.25	6.35	0.217	5.5	0.120	3.0	132645
.130	0.25	6.35	0.217	5.5	0.130	3.3	132646
.140	0.25	6.35	0.217	5.5	0.140	3.6	132647
.150	0.25	6.35	0.217	5.5	0.150	3.8	132648
.160	0.25	6.35	0.217	5.5	0.160	4.1	132649
.170	0.25	6.35	0.217	5.5	0.170	4.3	132650
.180	0.25	6.35	0.217	5.5	0.180	4.6	132651
.190	0.25	6.35	0.217	5.5	0.190	4.8	132652
.200	0.25	6.35	0.217	5.5	0.200	5.1	132653
.210	0.25	6.35	0.217	5.5	0.210	5.3	132654
.220	0.25	6.35	0.217	5.5	0.220	5.6	132655
.230	0.25	6.35	0.217	5.5	0.230	5.8	132656
.240	0.25	6.35	0.217	5.5	0.240	6.1	132657
.250	0.25	6.35	0.217	5.5	0.250	6.4	132658
.260	0.25	6.35	0.217	5.5	0.260	6.6	132659
.270	0.25	6.35	0.217	5.5	0.270	6.9	132660
.280	0.25	6.35	0.217	5.5	0.280	7.1	132661

EN We supply all kinds of TIGRALloy saw tips. Just give us dimensions and quantities.  
 DE Wir liefern alle Arten von TIGRALloy Sägezähne. Bitte geben Sie uns nur Abmessungen und Mengen an.  
 FR Nous fournissons toutes sortes de dents de scie TIGRALloy. Il suffit de nous donner des dimensions et des quantités s'il vous plaît.  
 IT Forniamo tutti i tipi di TIGRALloy inoltre ha visto punte. Per favore basta darci le dimensioni e le quantità soddisfanno.  
 HU Mindenféle és fajta TIGRALLOY fűrészfogak szállítunk. Kérjük, adja meg nekünk a méreteket és a mennyiséget.

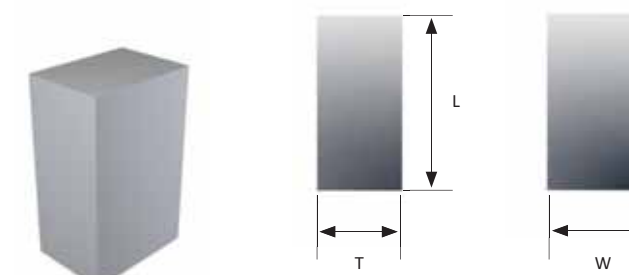

EN TIGRALloy - Saw tips  
 DE TIGRALloy - Sägezähne  
 FR TIGRALloy - Dents de scie  
 IT TIGRALloy - Dentelli per lame  
 HU TIGRALloy - Fűrészfogak

### Négyszögűek - hüvelyk

L	T	W	TL48	
			hüvelyk	mm
0.18	0.090	0.125	4.57	3.18
0.18	0.090	0.150	4.57	3.81
0.205	0.105	0.165	5.21	4.19
0.240	0.090	0.125	6.10	3.18
0.240	0.120	0.150	6.10	3.81
0.240	0.120	0.175	6.10	4.45
0.240	0.120	0.187	6.10	4.75
0.240	0.120	0.200	6.10	5.08
0.300	0.120	0.150	7.62	3.81
0.300	0.120	0.187	7.62	4.75
0.300	0.125	0.150	7.62	3.81
0.300	0.125	0.165	7.62	4.19
0.300	0.125	0.175	7.62	4.45
0.300	0.125	0.187	7.62	4.750
0.300	0.125	0.200	7.62	5.08
0.300	0.150	0.150	7.62	3.81
0.300	0.150	0.165	7.62	4.19
0.300	0.150	0.225	7.62	5.72
0.300	0.150	0.250	7.62	6.35

EN We supply all kinds of TIGRALloy saw tips. Just give us dimensions and quantities.  
 DE Wir liefern alle Arten von TIGRALloy Sägezähne. Bitte geben Sie uns nur Abmessungen und Mengen an.  
 FR Nous fournissons toutes sortes de dents de scie TIGRALloy. Il suffit de nous donner des dimensions et des quantités s'il vous plaît.  
 IT Forniamo tutti i tipi di TIGRALloy inoltre ha visto punte. Per favore basta darci le dimensioni e le quantità soddisfanno.  
 HU Mindenféle és fajta TIGRALLOY fűrészfogak szállítunk. Kérjük, adja meg nekünk a méreteket és a mennyiséget.



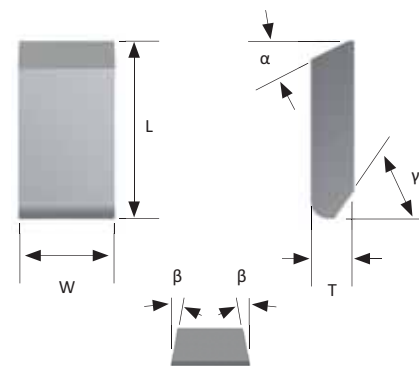

- EN TIGRAAlloy - Saw tips
- DE TIGRAAlloy - Sägezähne
- FR TIGRAAlloy - Dents de scie
- IT TIGRAAlloy - Dentelli per lame
- HU TIGRAAlloy - Fűrészfogak

hüvelyk

CWF	L hüvelyk	mm	T hüvelyk	mm	W/vágásrés hüvelyk	mm	TL48
.100	0.5	12.7	0.125	3.2	0.100	2.5	137175
.110	0.5	12.7	0.125	3.2	0.110	2.8	137176
.120	0.5	12.7	0.125	3.2	0.120	3.1	135859
.130	0.5	12.7	0.125	3.2	0.130	3.3	135860
.140	0.5	12.7	0.125	3.2	0.140	3.6	135861
.150	0.5	12.7	0.125	3.2	0.150	3.8	135862
.160	0.5	12.7	0.125	3.2	0.160	4.1	137177
.165	0.5	12.7	0.125	3.2	0.165	4.2	135863
.170	0.5	12.7	0.125	3.2	0.170	4.3	135864
.180	0.5	12.7	0.125	3.2	0.180	4.6	137178
.190	0.5	12.7	0.125	3.2	0.190	4.8	137179
.200	0.5	12.7	0.125	3.2	0.200	5.1	137180
.210	0.5	12.7	0.125	3.2	0.210	5.3	137181
.220	0.5	12.7	0.125	3.2	0.220	5.6	137182
.230	0.5	12.7	0.125	3.2	0.230	5.8	137183
.240	0.5	12.7	0.125	3.2	0.240	6.1	137184
.250	0.5	12.7	0.125	3.2	0.250	6.4	137185
.437	0.5	12.7	0.125	3.2	0.437	11.1	139104
.500	0.5	12.7	0.125	3.2	0.500	12.7	139105

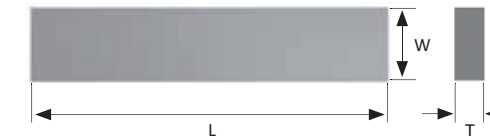

- EN TIGRAAlloy - Strips for brazed cutters
- DE TIGRAAlloy - Fräserplatten zum Löten
- FR TIGRAAlloy - Plaquettes à braser
- IT TIGRAAlloy - Placchette per frese saldobrasate
- HU TIGRAAlloy - Vágólapok forrasztottlapkás marókhoz

metrikus

L mm	W mm	T mm	TL60
165	20	5	050204
165	25	5	050205
165	30	5	050206
165	35	5	050207
165	40	5	050209
165	20	6	135244
165	25	6	108185
165	30	6	135602
165	36	6	135397
165	40	6	135603
165	25	8	119946
165	35	8	102188

STBs - hüvelyk



L hüvelyk	mm	W hüvelyk	mm	T hüvelyk	mm	TL60
6	152,4	1/2	12,7	3/32	2,38	046290
6	152,4	5/8	15,88	3/32	2,38	046291
6	152,4	3/4	19,05	3/32	2,38	046292
6	152,4	7/8	22,23	3/32	2,38	046293
6	152,4	1	25,4	3/32	2,38	046294
6	152,4	3/8	9,53	1/8	3,18	046295
6	152,4	1/2	12,7	1/8	3,18	046296
6	152,4	5/8	15,88	1/8	3,18	046297
6	152,4	3/4	19,05	1/8	3,18	046298
6	152,4	7/8	22,23	1/8	3,18	046299
6	152,4	1	25,4	1/8	3,18	046300
6	152,4	1 1/4	31,75	1/8	3,18	046301
6	152,4	1 1/2	38,1	1/8	3,18	046302
6	152,4	1/2	12,7	5/32	3,97	046460
6	152,4	5/8	15,88	5/32	3,97	046461
6	152,4	3/4	19,05	5/32	3,97	046462
6	152,4	7/8	22,23	5/32	3,97	046463
6	152,4	1	25,4	5/32	3,97	046464
6	152,4	1 1/2	38,1	5/32	3,97	046467
6	152,4	3/4	19,05	3/16	4,76	046472
6	152,4	1	25,4	3/16	4,76	050603
6	152,4	1 1/4	31,75	3/16	4,76	046475
6	152,4	1 1/2	38,1	3/16	4,76	046476

EN We supply all kinds of TIGRAAlloy saw tips. Just give us dimensions and quantities.  
 DE Wir liefern alle Arten von TIGRAAlloy Sägezähne. Bitte geben Sie uns nur Abmessungen und Mengen an.  
 FR Nous fournissons toutes sortes de dents de scie TIGRAAlloy. Il suffit de nous donner des dimensions et des quantités s'il vous plaît.  
 IT Forniamo tutti i tipi di TIGRAAlloy inoltre ha visto punte. Per favore basta darci le dimensioni e le quantità soddisfanno.  
 HU Mindenféle és fajta TIGRALLOY fűrészfogak szállítunk. Kérjük, adja meg nekünk a méreteket és a mennyiséget.











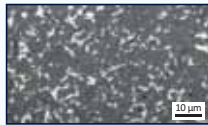

























































































- EN PCD - Blanks and segments
- DE PKD - Ronden und Segmente
- FR PCD - Rondelles et segments
- IT PCD - Dischi e settori
- HU PCD - Dia tárcsák és szegmensek

- EN PCD - Blanks and segments
- DE PKD - Ronden und Segmente
- FR PCD - Rondelles et segments
- IT PCD - Dischi e settori
- ES PCD - Dia tárcsák és szegmensek

	<p>EN PCD-Grade chart          DE PKD-Sortentabelle          FR Tableau des nuances PCD          IT PCD-Tabella dei tipi          HU PCD-Dia kategóriák táblázata</p>	<p>170 - 172</p>
	<p>EN Standard and special PCD blanks          DE Standard- und Spezial-PKD-Ronden          FR Rondelles PCD standard et spéciales          IT Dischi standard e speciali in PCD          HU Standard és speciális PCD dia tárcsák</p>	<p>173 - 174</p>
	<p>EN PCD segments          DE PKD-Segmente          FR Segments PCD          IT Settori in PCD          HU PCD-dia szegmensek</p>	<p>175 - 176</p>





EN PCD - Polycrystalline diamond- PCD grades and their applications  
 DE PKD - Polykristalliner Diamant- PKD-Sorten und ihre Anwendungen  
 FR PCD - Diamant policristallin - Les nuances de PCD et leurs applications  
 IT PCD - Diamante policristallino- I tipi di PCD e le loro applicazioni  
 HU PCD - Polikristályos gyémánt - PCD kategóriák és felhasználásuk

EN TIGRA grade DE TIGRA - Sorte FR Nuance TIGRA IT Tipo TIGRA HU TIGRA kategória	Grain size and structure Korngröße und -struktur Grosseur et structure du grain Grossezza e struttura del grano Szemcsenagyság és -szerkezet (µm)	Binder type Binderart Type de liant Tipo legante Kötőanyagtípus	Diamond content Diamantgehalt Teneur en diamant Contenuto di diamante Gyémánttartalom	Toughness Zähigkeit Ténacité Tenacità Szívósság	Bending strength Biegebruchfestigkeit Résistance à la flexion Resistenza flessionale Hajlítószilárdság	Abrasion resistance Verschleißfestigkeit Résistance à l'abrasion Resistenza all'abrasione Kopásállóság	EN Roughing DE Schruppen FR Dégrossissage IT Sgrossatura HU Nagyolás	Semi-finishing Vorschlichten Semi-finissage Semifinitura Félfinom felület	Finishing Schlichten Finissage Finitura Simítás	Super-finishing Feinschlichten Super-finissage Superfinitura Szuper simítás	Al <6% Si	Al 6-12% Si	Al >12% Si	Composites based on Verbundwerkstoffe auf Basis Composites à base Compositi a base Kompozit kötőanyaga	Comment Kommentar Commentaire Commento Megjegyzés		
													Fibers Fasern Fibres Fibre Szálak	Minerals Mineralien Minéraux Minerali Ásványok	Wood Holz Bois Legno Fa		
FX	2 - 4 	special	standard														EN For low Si%-Al DE Für niedrig-Si%-Al FR Pour un bas Si%-Al IT Per un basso Si%-Al HUAacsony Si%-Al-hoz
MS	8 - 10 	standard	standard														EN Universal use, medium grain DE Universeller Einsatz, mittl. Korn FR Utilisation univers., grain moyen IT Uso universale, grano medio HU Univerzális felhaszn., középsem.
MS-W*	8 - 10 	standard	standard														EN Universal for woodworking DE Universell für die Holzbearbeitung FR Universel pour le travail du bois IT Universale per la lavorazione del legno HU Univerzális ffeldolgozáshoz
MU+	2 - 4 + 8 - 10 	ultrakemény	nagyon magas														EN MDF, chipboard, laminate, CFRP DE MDF, Spanplatte, Laminat, CFK FR MDF, panneaux, stratifié, CFRP IT MDF, truciolato, laminato, CFRP HUMDF, forgácslap, laminátum, CFRP
MX+	8 - 10 	special	standard														EN Universal for aluminum DE Universell für Aluminium FR Universel pour l'aluminium IT Universale per alluminio HU Univerzális alumíniumhoz
CU	2 - 4 + 20 - 35 	ultrakemény	nagyon magas														EN Limestone, concrete, high impact DE Kalkstein, Beton, äußerst schlagzäh FR Calcaire, béton, à fort impact IT Calcare, calcestruzzo, ad alto impatto HUMészkö, beton, nagy ütőmunka
CX	20 - 35 	special	standard														EN For high Si%-Al DE Für hohen Si%-Al FR Pour une grande Si%-Al IT Per alta Si%-Al HUMagas Si%-Al-hoz

\* EN Special for woodworking  
 \* DE Speziell für die Holzbearbeitung  
 \* FR Spéciale pour le travail du bois  
 \* IT Speciale per la lavorazione del legno  
 \* HU Kijeztetten fagegmunkálásra

EN For technical data, please refer to page 7.  
 DE Die technischen Daten entnehmen Sie bitte der Seite 7.  
 FR Pour les données techniques, veuillez voir au page 7.

IT Per i dati tecnici, fare riferimento alla pagina 7.  
 HU A műszaki adatokat a 7. oldalon találja

 kiváló teljesítőképesség  
 nagyon jó teljesítmény  
 elfogadható  
 - nem alkalmas

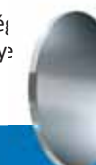



EN PCD - Further information  
 DE PKD - Weitere Informationen  
 FR PCD - Plus d'informations  
 IT PCD - Ulteriori informazioni  
 HU PCD - További információk

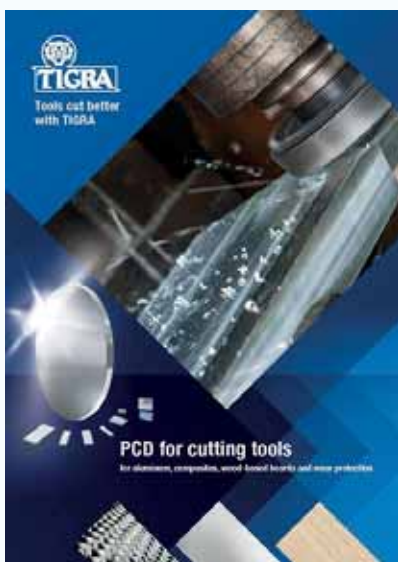

EN For detailed technical information, please download from our homepage [www.tigra.de](http://www.tigra.de) or ask for a printed copy of our technical guidebook "PCD for cutting tools".

DE Detaillierte technische Informationen finden Sie auf unserer Homepage [www.tigra.de](http://www.tigra.de) zum download oder fordern Sie ein gedrucktes Exemplar unseres technischen Ratgebers "PKD für Schneidwerkzeuge" an.

FR Pour des informations techniques détaillées, s'il vous plaît télécharger à partir de notre page d'accueil [www.tigra.de](http://www.tigra.de) ou demander une copie imprimée de notre guide technique "PCD pour les outils de coupe".

IT Potete scaricare le informazioni tecniche dettagliate dal nostro sito [www.tigra.de](http://www.tigra.de) oppure richiedere una copia stampata della nostra guida tecnica "PCD per utensili da taglio".

HU A részletes műszaki információkat kérjük, töltsé le [www.tigra.de](http://www.tigra.de) honlapunkról vagy kérje "PCD vágószerszámokhoz" műszaki útmutatónk nyomtatott példányát..

EN Standard PCD blanks  
 DE Standard-PKD-Ronden  
 FR Rondelles PCD standards  
 IT Dischi standard in PCD  
 HU Standard PCD tárcsák

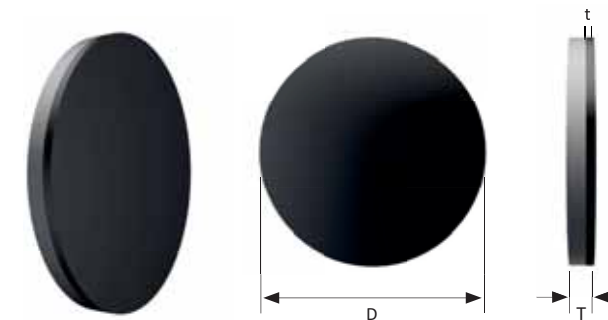

EN Grade DE Sorte FR Nuance IT Tipo HU Kategória	Tulajdonságok és méretek (mm)					Ø 62 mm Cikkszám
	Szemcse µm		Kötőanyag	T mm	t mm	
FX	Finom	2-4	Special	1.6	0.5	141046
				2.0	0.5	141047
				3.2	0.5	141048
MS	Közepes	8-10	Standard	1.6	0.5	139351
				2.0	0.5	139352
				3.2	0.5	141049
MS-W	Közepes	8-10	Standard	1.6	0.5	142725
				2.0	0.5	142727
MX+	Közepes	8-10	Special	1.6	0.5	141050
				2.0	0.5	141051
				3.2	0.5	141052
MU+	Kevért	2-4 + 8-10	Ultrakemény	1.6	0.5	139353
				2.0	0.5	139354
				3.2	0.5	141053
CX	Durva	20-35	Special	1.6	0.5	141057
				2.0	0.5	141058
				3.2	0.5	141059
CU	Kevért	2-4 + 20-35	Ultrakemény	1.6	0.5	141061
				2.0	0.5	141062
				3.2	0.5	141063

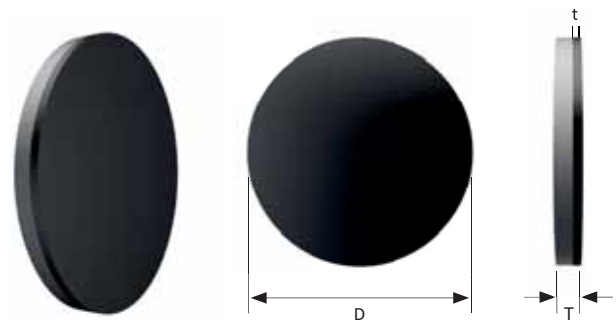

EN Special PCD blanks  
 DE Spezial-PKD-Ronden  
 FR Rondelles PCD spéciales  
 IT Dischi speciali in PCD  
 HU Speciális PCD tárcsák

EN Grade DE Sorte FR Nuance IT Tipo HU Kategória	Tulajdonságok és méretek				Ø 62 mm Cikkszám	
	Szemcse µm		Kötőanyag	T mm		t mm
FX	Finom	2-4	Special	1.0	0.3	141116
MS	Közepes	8-10	Standard	1.0	0.3	141117
				1.2	0.3	141118
MX+	Közepes	8-10	Special	1.0	0.3	141120
MU+	Kevert	2-4 + 8-10	Ultrakemény	1.0	0.3	141121
CX	Durva	20-35	Special	1.0	0.3	141125
CU	Kevert	2-4 + 20-35	Ultrakemény	1.0	0.3	141126

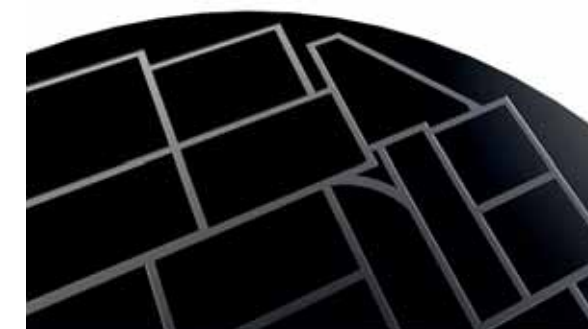

EN Standard PCD segments  
 DE Standard PKD-Segmente  
 FR Segments PCD standards  
 IT Settori standard in PCD  
 HU Standard PCD szegmensek

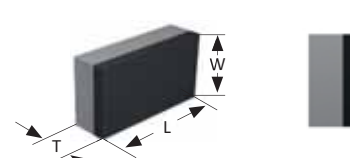
EN Rectangle DE Rechteck FR Rectangle IT Rettangolo HU Négyzetleges	
	<p>RE L x W / T - Grade</p> <p>Példa RE 5.5 x 3.0 / 1.6 - MX</p>

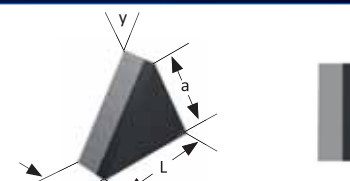
EN Triangle DE Dreieck FR Triangle IT Triangolo HU Háromszög	
	<p><math>\gamma</math> T a / T - Grade</p> <p>Példa 60 T 5.0 / 1.6 - MX</p>

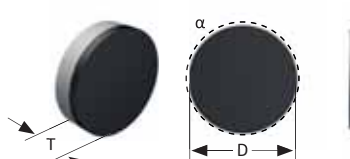
EN Round DE Rund FR Rond IT Rotondo HU Kerek	
	<p><math>\alpha</math> R D / T - Grade</p> <p>Példa teljes körre 360 R 20.0 / 1.6 - MX</p> <p>Példa félkörre 180 R 22.4 / 1.6 - MX</p>

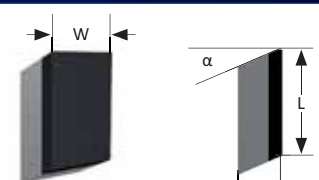
EN With angle DE Mit Winkel FR Avec angle IT Con angolo HU Élszöggel	
	<p>RE L x W / <math>\alpha</math> / T - Grade</p> <p>Példa RE 4 x 3 / 24° / 1.6 - MX</p>

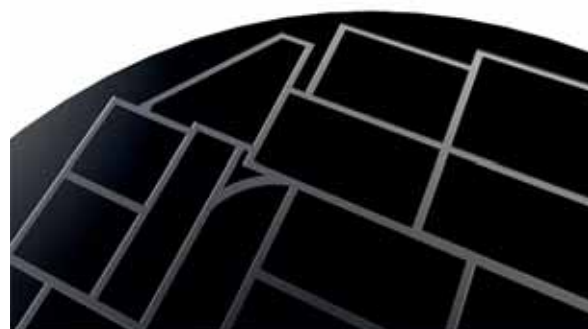

EN Cutting service  
 DE Schneiddienst  
 FR Service de coupe  
 IT Servizio di taglio  
 HU Darabolási szolgáltatás

EN TIGRA offers you a quick service for laser-cut PCD: according to your drawing, we cut within 3-5 working days, with and without angle. The segments are delivered cleaned and packaged safely. Thanks to the efficient production planning and processing, our laser-cut segments are in many cases significantly less expensive than whatever is possible by wire cutting!

DE TIGRA bietet Ihnen einen Schnellservice für Laser geschnittenes PKD: nach Ihrer Zeichnung trennen wir innerhalb von 3-5 Arbeitstagen, mit und ohne Winkel. Die Segmente werden gereinigt und sicher verpackt ausgeliefert. Dank der effizienten Arbeitsvorbereitung und Bearbeitung sind unsere Laser geschnittenen Segmente in vielen Fällen deutlich günstiger als dies mit Drahtschneiden möglich ist!

FR TIGRA vous offre un service express pour PCD découpé au laser. Nous découpons avec ou sans angle et suivant votre dessin dans un délai de 3-5 jours ouvrables. Les segments sont nettoyés et livrés solidement emballés. Nos segments découpés au laser sont dans de nombreux cas nettement plus avantageux que par découpe par fil grâce à la préparation du travail et à l'usinage efficaces!

IT TIGRA vi offre un servizio rapido per PCD tagliato a laser: in base ai vostri disegni, eseguiamo i tagli entro 3-5 giorni lavorativi, con e senza angoli. I settori vengono puliti e spediti in imballi sicuri. Grazie all'efficienza di preparazione e lavorazione, i nostri settori tagliati a laser sono spesso più economici di quelli ottenuti con una macchina ad elettroerosione!

HU A TIGRA gyors szolgáltatást ajánl PCD lézer darabolásra: rajza szerint 3-5 munkanapon belül, élszöggel vagy anélkül. A szegmensek megtisztítva és biztonságosan becsomagolva kerülnek kiszállításra. A hatékony munkaelőkészítésnek és megmunkálásnak köszönhetően lézervágott szegmenseink sok esetben jelentősen kedvezőbb árúak, mint amilyenek szikraforgácsolással lehetségesek!

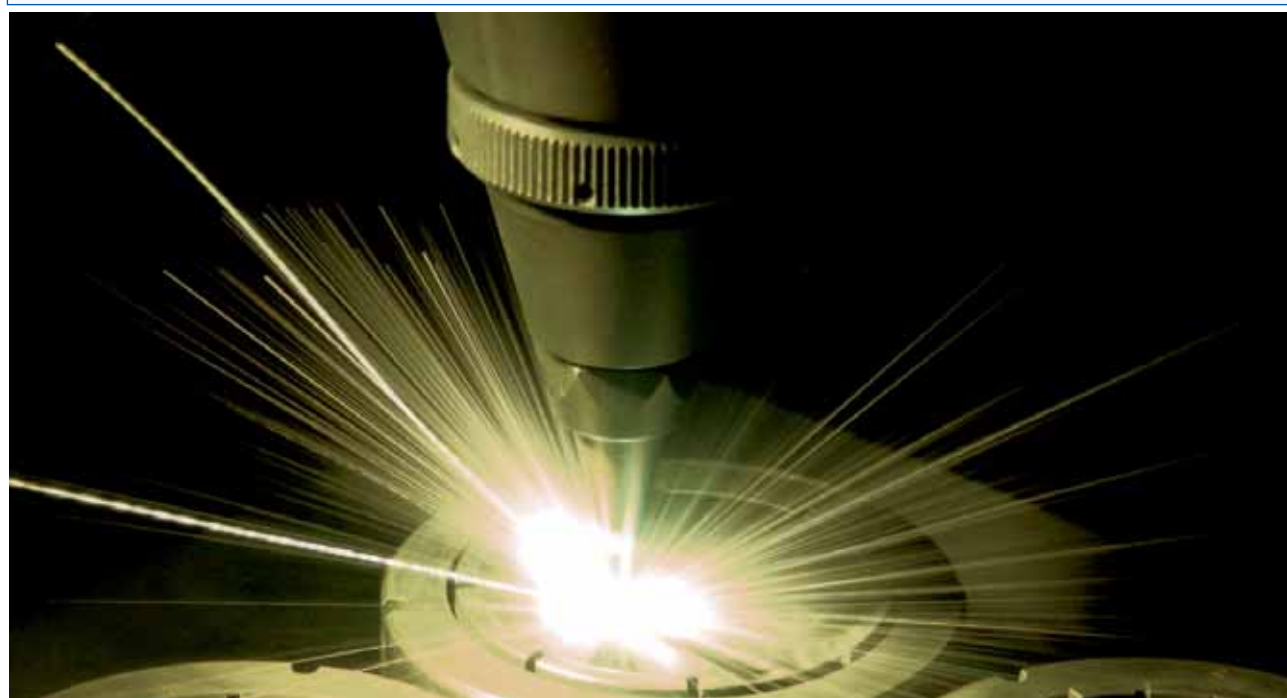

EN Warning  
 DE Warnung  
 FR Mise en garde  
 IT Avvertenza  
 HU Figyelmeztetés

EN This catalogue describes cemented carbide products. Grinding of these products will produce dust of potentially hazardous ingredients. Dust from grinding the products described in this catalogue can cause nose, throat, skin and eye irritation and temporary or permanent respiratory disease in a small percentage of exposed individuals. Permanent respiratory disease can lead to disability or death. Coolant mist from wet grinding may contain dust. Avoid prolonged skin contact with dust or mist. Use adequate ventilation when grinding. Maintain dust levels below OSHA and ACGIH levels. Use protective devices. Wash hand thoroughly after handling, before eating or smoking. Dispose of materials according to local, state and/or federal regulations.

DE Der Schleifstaub der in diesem Katalog beschriebenen Hartmetallprodukte enthält möglicherweise gesundheitsschädliche Bestandteile. Er kann Nasen-, Atmungs-, Haut- und Augenreizungen auslösen. Dauerhaftes Einatmen kann zu ernsthaften gesundheitlichen Schäden führen. Beim Schleifen mit Kühlung entsteht ein Schlamm, der diesen Staub ebenfalls enthält. Vermeiden Sie das Einatmen von Schleifstaub und Schleifschlamm sowie längeren Hautkontakt. Sorgen Sie für ausreichende Absaugung. Benutzen Sie Schutzvorrichtungen. Waschen Sie sich nach der Berührung sorgfältig die Hände, insbesondere vor dem Essen. Die Entsorgung von Rückständen muss nach den entsprechenden gesetzlichen Vorschriften erfolgen.

FR La poussière de meulage des produits en carbure décrits dans ce catalogue risque de contenir des éléments dangereux pour la santé. Elle peut provoquer des irritations du nez, des voies respiratoires, de la peau et des yeux. Une inhalation prolongée peut provoquer de graves problèmes de santé. Pendant le meulage avec refroidissement, il se forme du cambouis qui contient également cette poussière. Evitez d'inhaler la poussière et le cambouis de meulage, ainsi que tout contact prolongé avec la peau. Veillez à ce que leur aspiration soit suffisante. Utilisez des dispositifs de protection. Après tout contact, lavez-vous soigneusement les mains, surtout avant les repas. La mise au rebut des résidus doit se faire conformément aux prescriptions légales en vigueur.

IT Il pulviscolo di rettifica del prodotto in metallo duro descritto nel presente catalogo può contenere componenti dannosi per la salute. Può causare irritazione a naso, vie respiratorie, pelle e occhi. L'esposizione prolungata a queste sostanze e la conseguente inalazione possono causare seri danni alla salute. Anche in caso di profilatura a freddo si produce un residuo fangoso che contiene questo pulviscolo. Evitare l'inalazione e il contatto prolungato con la pelle del pulviscolo di rettifica e dei residui. Eseguire un'accurata pulizia e adottare idonee misure di protezione. Lavare accuratamente le mani dopo ogni contatto, soprattutto prima dei pasti. Smaltire i residui in conformità alle normative vigenti in materia.

HU Az ebben a katalógusban felsorolt vídiatermékek élezéskor keletkező csiszolópora valószínűsíthetően egészségkárosító alkotóelemeket tartalmaz. Orr-, légzési, bőr- és szemirritációt idézhet elő. Tartós belélegzése súlyos egészségkárosodáshoz vezethet. Hűtőfolyadékkal csiszolva olyan iszap keletkezik, amely ezt a port ugyancsak tartalmazza. Kerülje el a csiszolópor és köszörű iszap belélegzését és bőrrel való hosszabb érintkezését. Gondoskodjon megfelelő elszívásról. Használjon személyi védőeszközöket. Érintkezést követően alaposan mosson kezet, különösen étkezés vagy dohányzást megelőzően. A visszamaradó por és iszap ártalmatlanítását a vonatkozó jogszabályi előírásoknak megfelelően kell végrehajtani.





- EN Notes
- DE Notizen
- FR Notes
- IT Note
- ES Notas

---

---

---

---

---

---

---

---

---

---

---

---

---

---

---

---

---

---

---

---

---

---

---

---

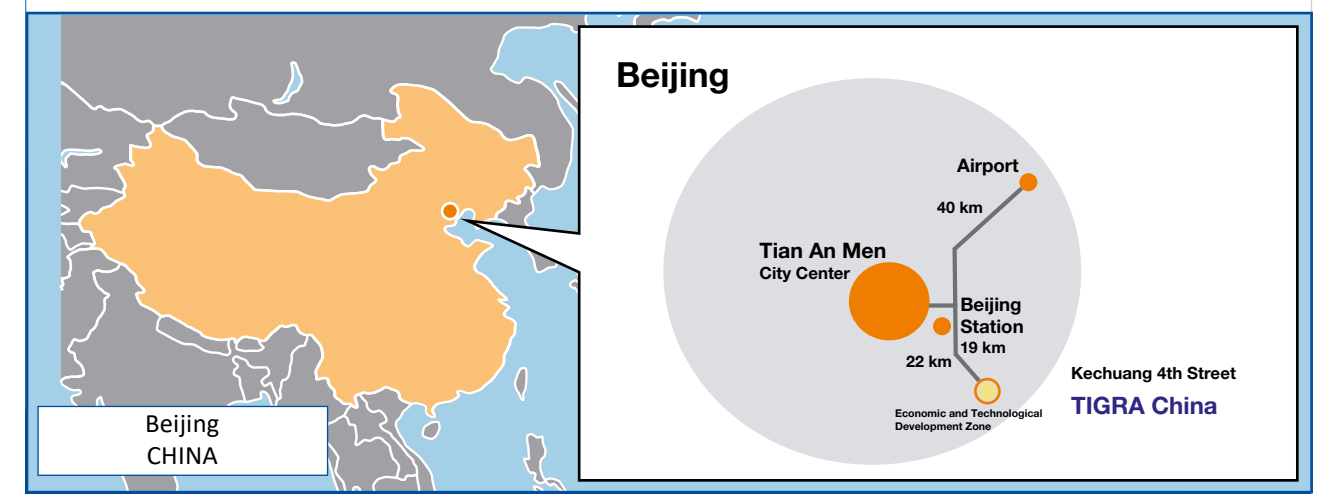
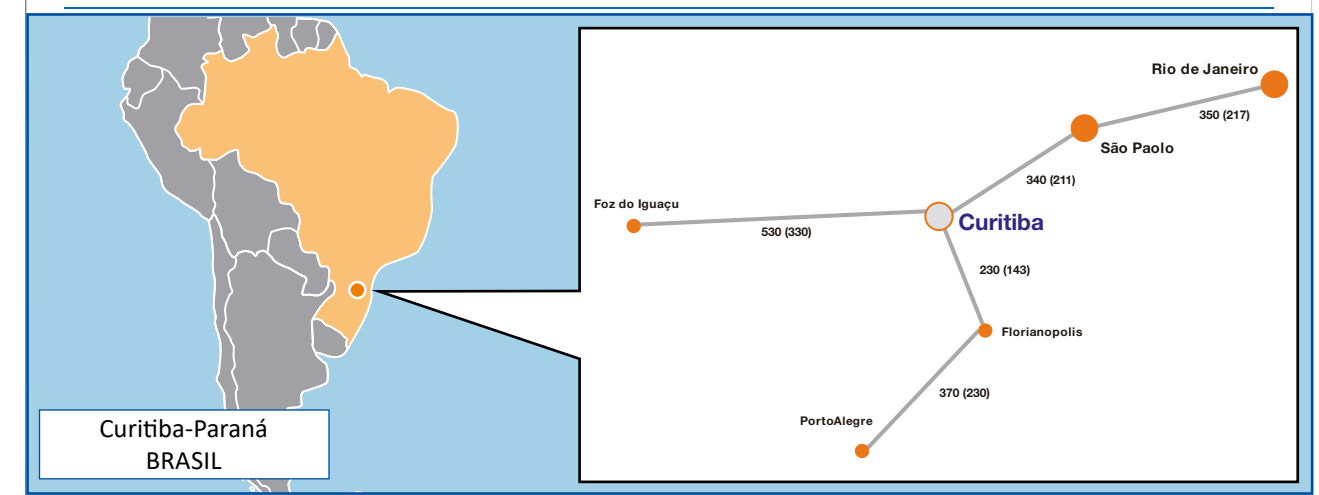
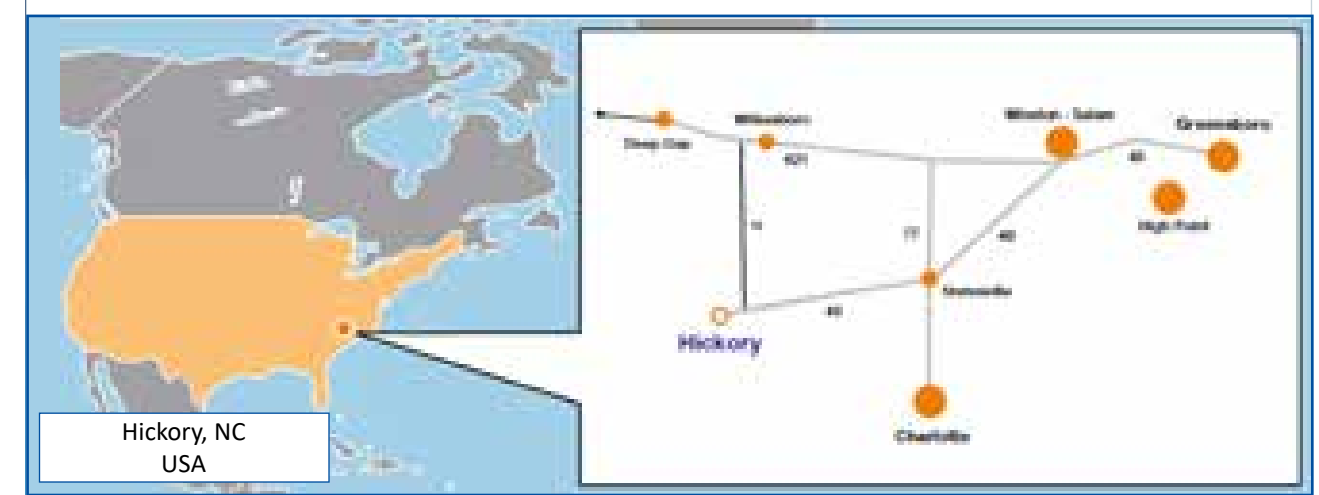
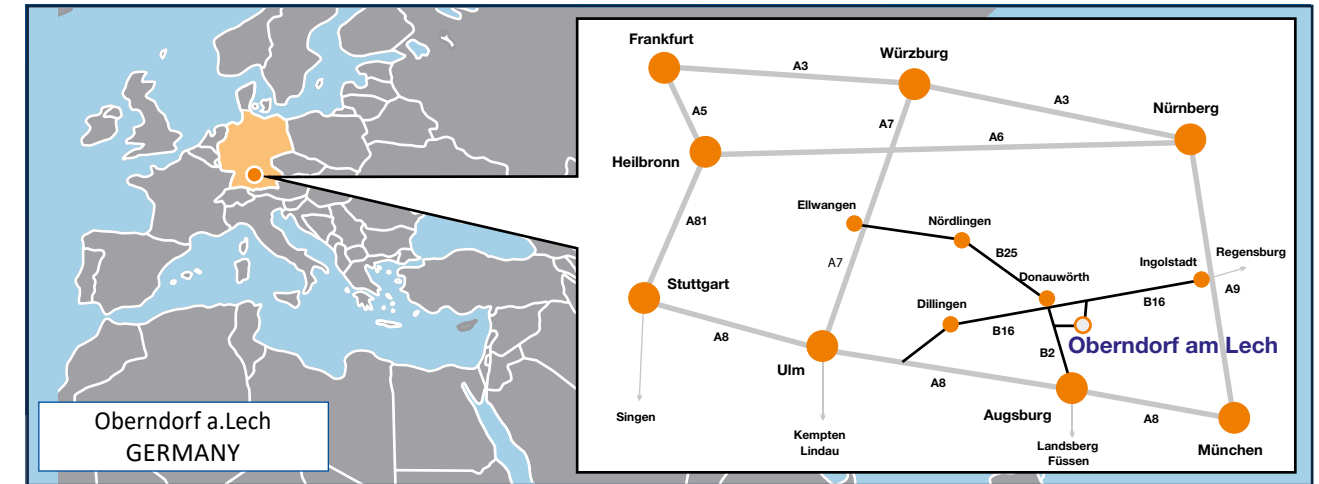



**Tools cut better  
with TIGRA**

[www.tigra.com](http://www.tigra.com)

**TIGRA GmbH**

Gewerbering 2  
D-86698 Oberndorf am Lech · Germany  
Phone +49 (0)9090 9680-01  
[www.tigra.com](http://www.tigra.com) · [sales@tigra.de](mailto:sales@tigra.de)



**TIGRA USA, Inc.**

1106 8<sup>th</sup> ST CT SE  
Hickory, NC 28602 · USA  
Phone +1 828-324-8227  
[www.tigra.com](http://www.tigra.com) · [sales@tigra-usa.com](mailto:sales@tigra-usa.com)



**TIGRA do Brasil Ltda.**

Rua Iapó, 1730, Prado Velho  
80215-223 Curitiba-Paraná · Brasil  
Phone +55 41 3276 3731  
[www.tigra.com](http://www.tigra.com) · [brasil@tigra.com](mailto:brasil@tigra.com)



**TIGRA China Carbides Co. Ltd.**

1-109 No.36 Kechuang 4th Street  
BDA Beijing, P.R. China 100176  
Phone +86 10 5352 1598  
[www.tigra-china.com](http://www.tigra-china.com) · [sales@tigra-china.com](mailto:sales@tigra-china.com)

