



# freud

Precisely  
the best

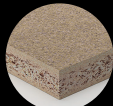

**LSBX NeXt Generation**  
Premium lapszabász körfűrészek

## A LEGNAGYOBB KÖRFÜRÉSZ VÁLASZTÉK LAPSZABÁSZ GÉPEKRE

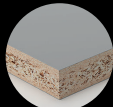
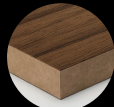
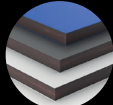
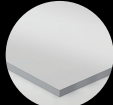
FORGÁCSLAP & MDF			● ● ●
LAMINÁLT FORGÁCSLAP & MDF			● ● ●
HPL			● ●
PLEXIÜVEG			● ●

Teljesítőképesség jelmagyarázata

● ● ● Kimagasló ● ● Nagy ● Jó

## AUTOMATA LAPSZABÁSZ GÉPEKHEZ

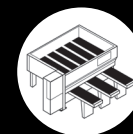

## SZÉLES ÁTMÉRŐTARTOMÁNYBAN KAPHATÓ

250 mm-től

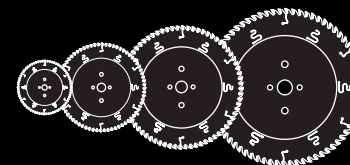

720 mm-ig



**Rendkívüli teljesítőképesség**  
Házon belül gyártott, nagy tartósságú titánium-kobalt vídia



**Kiváló korrózióállóság és súrlódáscsökkentés**  
Silver I.C.E. bevonat.



**Alacsony zajszint**  
Egyedi rezgés-csökkentő rések.



**Megnövelt él(et)tartam akár 25 újraélezésig**  
Szupersarkított fog kialakítás



**EXtrém ütésállóság**  
A speciális háromfémű forrasztóvíz ellenáll az extrém ütéseknek

**Kivételes vágási felületminőség**  
Megnövelt test stabilitás.

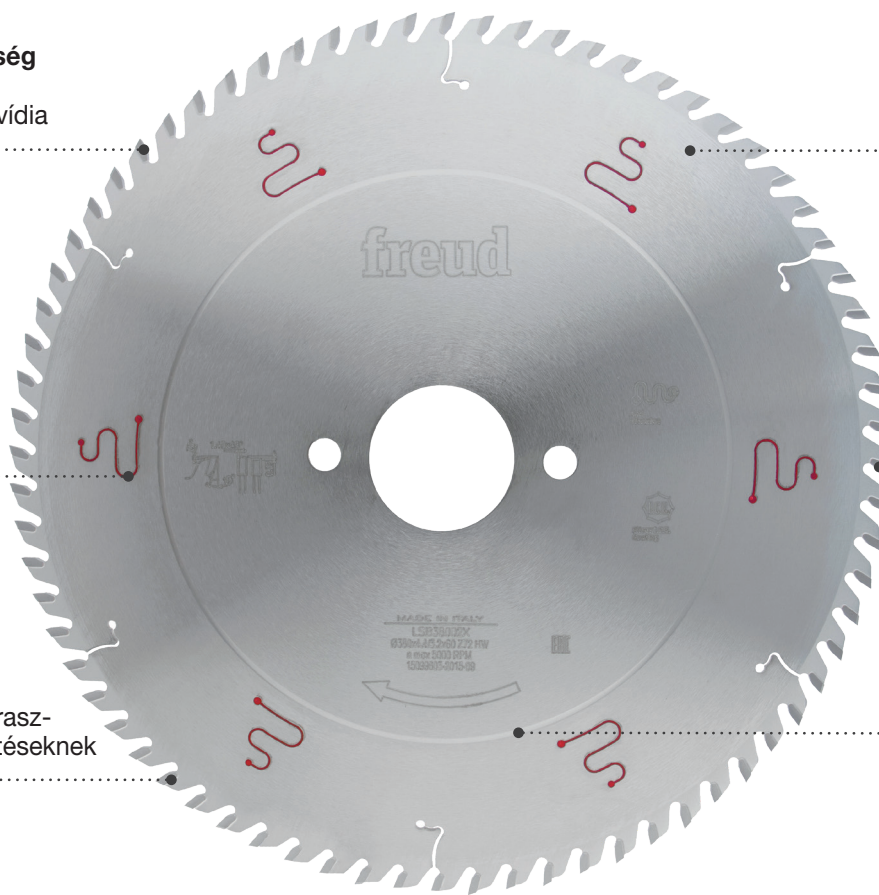

## TiCo vídia

- A Freud által kifejlesztett és gyártott, speciális formulázású igen kompakt nagy sűrűségű titán-kobalt vídia.
- Élesebb éleket és hibátlan felületminőséget biztosít drámaian megnövekedett élettartammal.



## Silver I.C.E. bevonat

- Nagy teljesítményű és korrózióvédő bevonat a fűrész hőmérsékletének alacsonyán tartására munkavégzőskor.
- Tapadásmentes tulajdonsága fokozza a forgácskibotást és különösképpen csökkenti a gyantalerakódást, a surlódást és megnöveli a fűrész él(et)tartamát.



## Rezgéscsökkentő rések

- A Freud innovatív technológiájával lézervágott rések az alaptesten.
- Termoplasztikus poliuretán töltés is kapható, amely jelentősen csökkenti a rezgéseket és minimalizálja a zajkeltést.



**Alkalmas több mint**

**130 lapszabász géphez a legnépszerűbb márkákból:**

**AES ANTHON AYZA MIZRAK**

**BIESSE FIMAL FELDER MAYER**

**GABBIANI GIBEN HOLZER**

**HOLZMA HOMAG NANXING**

**NIMAK PANHANS SCHEER KOCH**

**SHELLING SCM SCM-GABBIANI**

**TÖRK MAKINE TURANLAR**

# JELÖLÉSEK ÉS RÖVIDÍTÉSEK MAGYARÁZATA

## Útmutató a terméktáblázatokhoz

<b>D</b>	Külső átmérő (mm)	<b>B</b>	Vágás szélesség (mm)	<b>B-B1</b>	Állítható vágás-szélesség (mm)	<b>b</b>	Test vastagság (mm)
<b>d</b>	Középfurat átmérő (mm)	<b>Z</b>	Fogak száma	<b><math>\alpha</math></b>	Homlok-szög ( $^{\circ}$ )	<b><math>\beta</math></b>	Hát-szög ( $^{\circ}$ )

 Rezgéscsökkentő rések

## Optimalizált foggeometria

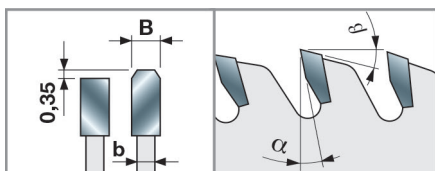

Az LSB X sorozat ideális választást képviseli ipari lapszabászathoz. A fűrész tárcsák alkalmasak laminált forgácslap és MDF panelekhez. Jó felületminőség HPL és akril panelek vágásánál is.

## Útmutató az illesztőfuratokhoz

Példa

Illesztőfuratok	Freud kód	Cikksz.
● 2/10/60 + ● 2/13/94	példa	példa

● Középpontok távolsága  
● Illesztőfura átmérő  
● Illesztőfuratok száma

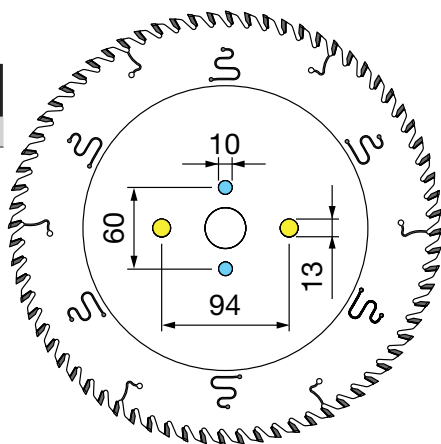

# TALÁLJA MEG A TÖKÉLETES LAPSZABÁSZ KÖRFÜRÉSZ KÉSZLETET GÉPTÍPUSONKÉNT

BIESSE-SELCO

IES - ANTHON  
AYZA MIZRAK

FELDER  
FIMAL  
GIBEN  
MAYER

HOLZER  
HOLZMA

HOMAG  
NANXING

NIMAC  
SCHEER  
SCHELLING  
PANHANS

SCM-GABBIANI  
TÖRK MAKINE  
TURANLAR

LSB X RANGE  
BY DIAMETER

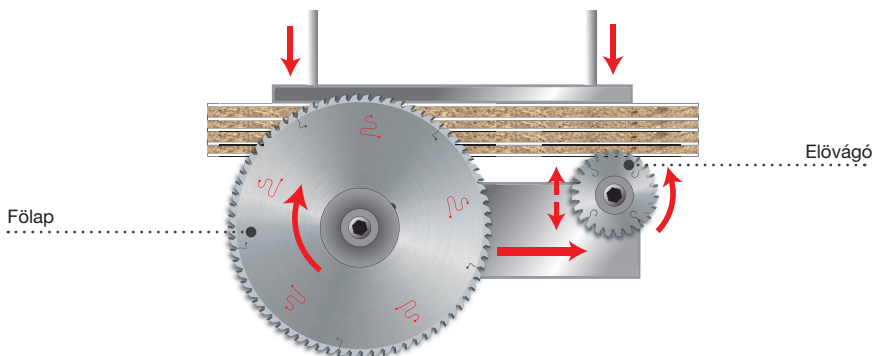

Gép-típus	Lap típus	D	B-B1	b	d	Z	Fog-típus	$\alpha$	$\beta$	ill. furatok	Freud kód	Cikksz.
		mm	mm	mm	mm							
<b>BIESSE-SELCO</b>												
EB 70 (L)	Fö-lap	300	4,4	3	65	60	TCG	15°	15°	2/9/110	LSB30002X	F03FS09159
	HW Elövágó	200	4,3-5,5	3,2	65	36	ATB	8°	15°	2/9/100 + 2/9/110	LI25M43PI3	F03FS02681
	HW Elövágó	300	4,3-5,5	3	65	48	ATB	12°	15°	2/9/100 + 2/9/110	LI25M43RX3	F03FS07616
	Dia Elövágó	200	4,3-5,1	3,2	65	36	FLAT	6°	14°	2/9/100 + 2/9/110	DLI25M43PIH4	F03FS09625
	Dia Elövágó	200	4,3-5,1	3,2	65	36	FLAT	6°	14°	2/9/100 + 2/9/110	DLI25M43PIH6	F03FS09626
	Utófor-elövágó	300	4,55	3,2	65	72	ATB	15°	15°	2/9/100 + 2/9/110	LI27M DA3	F03FS02737
EB 70 (KIT 80), 75 (SEKTOR 430), 80 (SEKTOR 450), SK350, SK450	Fö-lap	320	4,4	3,2	65	60	TCG	15°	15°	2/9/110	LSB32003X	F03FS09161
	Fö-lap	320	4,4	3,2	65	72	TCG	15°	15°	2/9/95 + 2/9/110	LSB32001X	F03FS07805
	HW Elövágó	200	4,3-5,5	3,2	65	36	ATB	8°	15°	2/9/100 + 2/9/110	LI25M43PI3	F03FS02681
	HW Elövágó	300	4,3-5,5	3	65	48	ATB	12°	15°	2/9/100 + 2/9/110	LI25M43RX3	F03FS07616
	Dia Elövágó	200	4,3-5,1	3,2	65	36	FLAT	6°	14°	2/9/100 + 2/9/110	DLI25M43PIH4	F03FS09625
	Dia Elövágó	200	4,3-5,1	3,2	65	36	FLAT	6°	14°	2/9/100 + 2/9/110	DLI25M43PIH6	F03FS09626
WN2, WN230, SK230	Utófor-elövágó	300	4,55	3,2	65	72	ATB	15°	15°	2/9/100 + 2/9/110	LI27M DA3	F03FS02737
	Fö-lap	320	4,4	3,2	65	72	TCG	15°	15°	2/9/95 + 2/9/110	LSB32001X	F03FS07805
	HW Elövágó	200	4,3-5,5	3,2	65	36	ATB	8°	15°	2/9/100 + 2/9/110	LI25M43PI3	F03FS02681
	Dia Elövágó	200	4,3-5,1	3,2	65	36	FLAT	6°	14°	2/9/100 + 2/9/110	DLI25M43PIH4	F03FS09625
	Dia Elövágó	200	4,3-5,1	3,2	65	36	FLAT	6°	14°	2/9/100 + 2/9/110	DLI25M43PIH6	F03FS09626

freud

Gép-típus	Lap-típus	D	B-B1	b	d	Z	Fog-típus	$\alpha$	$\beta$	ill. furatok	Freud kód	Cikksz.
		mm	mm	mm	mm							
WN 250	Fő-lap	350	4,4	3,2	65	72	TCG	15°	15°	2/9/110	LSB35013X	F03FS09659
	HW Elővágó	200	4,3-5,5	3,2	65	36	ATB	8°	15°	2/9/100 + 2/9/110	LI25M43PI3	F03FS02681
	Dia Elővágó	200	4,3-5,1	3,2	65	36	FLAT	6°	14°	2/9/100 + 2/9/110	DLI25M43PIH4	F03FS09625
	Dia Elővágó	200	4,3-5,1	3,2	65	36	FLAT	6°	14°	2/9/100 + 2/9/110	DLI25M43PIH6	F03FS09626
EB 95, SEKTOR 470, K470, SK370	Fő-lap	355	4,4	3,2	65	72	TCG	15°	15°	2/9/95 + 2/9/110	LSB35508X	F03FS08740
	HW Elővágó	200	4,3-5,5	3,2	65	36	ATB	8°	15°	2/9/100 + 2/9/110	LI25M43PI3	F03FS02681
	HW Elővágó	300	4,3-5,5	3	65	48	ATB	12°	15°	2/9/100 + 2/9/110	LI25M43RX3	F03FS07616
	Dia Elővágó	200	4,3-5,1	3,2	65	36	FLAT	6°	14°	2/9/100 + 2/9/110	DLI25M43PIH4	F03FS09625
	Dia Elővágó	200	4,3-5,1	3,2	65	36	FLAT	6°	14°	2/9/100 + 2/9/110	DLI25M43PIH6	F03FS09626
	Utófor. elővágó	300	4,55	3,2	65	72	ATB	15°	15°	2/9/100 + 2/9/110	LI27M DA3	F03FS02737
EB100	Fő-lap	360	4,4	3,2	65	72	TCG	15°	15°	2/9/95 + 2/9/110	LSB36002X	F03FS07673
	HW Elővágó	200	4,3-5,5	3,2	65	36	ATB	8°	15°	2/9/100 + 2/9/110	LI25M43PI3	F03FS02681
	HW Elővágó	300	4,3-5,5	3	65	48	ATB	12°	15°	2/9/100 + 2/9/110	LI25M43RX3	F03FS07616
	Dia Elővágó	200	4,3-5,1	3,2	65	36	FLAT	6°	14°	2/9/100 + 2/9/110	DLI25M43PIH4	F03FS09625
	Dia Elővágó	200	4,3-5,1	3,2	65	36	FLAT	6°	14°	2/9/100 + 2/9/110	DLI25M43PIH6	F03FS09626
	Utófor. elővágó	300	4,55	3,2	65	72	ATB	15°	15°	2/9/100 + 2/9/110	LI27M DA3	F03FS02737
WN-WNA 610, WN-WNA 610 (PFS)	Fő-lap	380	4,4	3,2	65	72	TCG	15°	15°	2/9/110	LSB38014X	F03FS09166
	HW Elővágó	200	4,3-5,5	3,2	65	36	ATB	8°	15°	2/9/100 + 2/9/110	LI25M43PI3	F03FS02681
	HW Elővágó	300	4,3-5,5	3	65	48	ATB	12°	15°	2/9/100 + 2/9/110	LI25M43RX3	F03FS07616
	Dia Elővágó	200	4,3-5,1	3,2	65	36	FLAT	6°	14°	2/9/100 + 2/9/110	DLI25M43PIH4	F03FS09625
	Dia Elővágó	200	4,3-5,1	3,2	65	36	FLAT	6°	14°	2/9/100 + 2/9/110	DLI25M43PIH6	F03FS09626
EB108, EB110, EB120	Fő-lap	400	4,4	3,2	80	72	TCG	15°	15°	2/15/105 + 2/9/130 + 4/19/120	LSB40009X	F03FS07810
	HW Elővágó	200	4,3-5,5	3,2	65	36	ATB	8°	15°	2/9/100 + 2/9/110	LI25M43PI3	F03FS02681
	HW Elővágó	300	4,3-5,5	3	65	48	ATB	12°	15°	2/9/100 + 2/9/110	LI25M43RX3	F03FS07616
	Dia Elővágó	200	4,3-5,1	3,2	65	36	FLAT	6°	14°	2/9/100 + 2/9/110	DLI25M43PIH4	F03FS09625
	Dia Elővágó	200	4,3-5,1	3,2	65	36	FLAT	6°	14°	2/9/100 + 2/9/110	DLI25M43PIH6	F03FS09626
	Utófor. elővágó	300	4,55	3,2	65	72	ATB	15°	15°	2/9/100 + 2/9/110	LI27M DA3	F03FS02737

Gép-típus	Lap-típus	D	B-B1	b	d	Z	Fog-típus	$\alpha$	$\beta$	ill. furatok	Freud kód	Cikksz.
		mm	mm	mm	mm							
WN-WNA 630, WN-WNA 630 (PFS)	Fő-lap	400	4,4	3,2	65	72	TCG	15°	15°	2/9/110	LSB40016X	F03FS09172
	HW Elővágó	200	4,3-5,5	3,2	65	36	ATB	8°	15°	2/9/100 + 2/9/110	LI25M43PI3	F03FS02681
	HW Elővágó	300	4,3-5,5	3	65	48	ATB	12°	15°	2/9/100 + 2/9/110	LI25M43RX3	F03FS07616
	Dia Elővágó	200	4,3-5,1	3,2	65	36	FLAT	6°	14°	2/9/100 + 2/9/110	DLI25M43PIH4	F03FS09625
	Dia Elővágó	200	4,3-5,1	3,2	65	36	FLAT	6°	14°	2/9/100 + 2/9/110	DLI25M43PIH6	F03FS09626
EB/EBT 120, WN 125	Fő-lap	430	4,4	3,2	80	72	TCG	15°	15°	2/9/130 + 2/14/110 + 4/19/120	LSB43009X	F03FS07909
	HW Elővágó	200	4,3-5,5	3,2	65	36	ATB	8°	15°	2/9/100 + 2/9/110	LI25M43PI3	F03FS02681
	HW Elővágó	300	4,3-5,5	3,2	65	72	ATB	12°	15°	2/9/100 + 2/9/110	LI25M43RI3	F03FS02689
	Dia Elővágó	200	4,3-5,1	3,2	65	36	FLAT	6°	14°	2/9/100 + 2/9/110	DLI25M43PIH4	F03FS09625
	Dia Elővágó	200	4,3-5,1	3,2	65	36	FLAT	6°	14°	2/9/100 + 2/9/110	DLI25M43PIH6	F03FS09626
	Utófor. elővágó	300	4,55	3,2	65	72	ATB	15°	15°	2/9/100 + 2/9/110	LI27M DA3	F03FS02737
WN-WNA 650, WN-WNA 650 (PFS)	Fő-lap	430	4,4	3,2	65	72	TCG	15°	15°	2/9/110	LSB43012X	F03FS09178
	HW Elővágó	200	4,3-5,5	3,2	65	36	ATB	8°	15°	2/9/100 + 2/9/110	LI25M43PI3	F03FS02681
	HW Elővágó	300	4,3-5,5	3	65	48	ATB	12°	15°	2/9/100 + 2/9/110	LI25M43RX3	F03FS07616
	Dia Elővágó	200	4,3-5,1	3,2	65	36	FLAT	6°	14°	2/9/100 + 2/9/110	DLI25M43PIH4	F03FS09625
	Dia Elővágó	200	4,3-5,1	3,2	65	36	FLAT	6°	14°	2/9/100 + 2/9/110	DLI25M43PIH6	F03FS09626
WN 710, WN 710 (PFS)	Fő-lap	430	4,8	3,5	70	72	TCG	15°	15°	4/11/130	LSB43013X	F03FS09180
	HW Elővágó	200	4,7-5,9	3,5	65	36	ATB	8°	15°	2/9/100 + 2/9/110	LI25M47PI3	F03FS02720
	HW Elővágó	300	4,7-5,9	3,5	65	48	ATB	6°	15°	2/9/110	LI25M47RX3	F03FS07744
	Dia Elővágó	200	4,7-5,5	3,5	65	36	FLAT	6°	14°	2/9/100 + 2/9/110	DLI25M47PIH4	F03FS09631
	Dia Elővágó	200	4,7-5,5	3,5	65	36	FLAT	6°	14°	2/9/100 + 2/9/110	DLI25M47PIH6	F03FS09632
WN 600/132, WN 200	Fő-lap	450	4,8	3,5	80	72	TCG	15°	15°	2/14/125 + 2/9/130 + 4/19/120	LSB45018X	F03FS07812
	HW Elővágó	200	4,7-5,9	3,5	65	36	ATB	8°	15°	2/9/100 + 2/9/110	LI25M47PI3	F03FS02720
	Dia Elővágó	200	4,7-5,5	3,5	65	36	FLAT	6°	14°	2/9/100 + 2/9/110	DLI25M47PIH4	F03FS09631
	Dia Elővágó	200	4,7-5,5	3,5	65	36	FLAT	6°	14°	2/9/100 + 2/9/110	DLI25M47PIH6	F03FS09632
	Utófor. elővágó	300	4,95	3	65	72	ATB	15°	15°	2/9/100 + 2/9/110	LI27M DB3	F03FS02739

Gép-típus	Lap-típus	D	B-B1	b	d	Z	Fog-típus	$\alpha$	$\beta$	ill. furatok	Freud kód	Cikksz.
		mm	mm	mm	mm							
WN 600/132, WN 200	Fő-lap	450	4,8	3,5	80	72	TCG	15°	15°	2/14/125 + 2/9/130 + 4/19/120	LSB45018X	F03FS07812
	HW Elővágo	200	4,7-5,9	3,5	65	36	ATB	8°	15°	2/9/100 + 2/9/110	LI25M47PI3	F03FS02720
	Dia Elővágo	200	4,7-5,5	3,5	65	36	FLAT	6°	14°	2/9/100 + 2/9/110	DLI25M47PIH4	F03FS09631
	Dia Elővágo	200	4,7-5,5	3,5	65	36	FLAT	6°	14°	2/9/100 + 2/9/110	DLI25M47PIH6	F03FS09632
	Utófor. elővágo	300	4,95	3	65	72	ATB	15°	15°	2/9/100 + 2/9/110	LI27M DB3	F03FS02739
WN-WNA 730, WN-WNA 730 (PFS)	Fő-lap	470	4,8	3,5	70	72	TCG	15°	15°	4/11/130	LSB47005X	F03FS09185
	HW Elővágo	200	4,7-5,9	3,5	65	36	ATB	8°	15°	2/9/100 + 2/9/110	LI25M47PI3	F03FS02720
	HW Elővágo	300	4,7-5,9	3,5	65	48	ATB	6°	15°	2/9/110	LI25M47RX3	F03FS07744
	Dia Elővágo	200	4,7-5,5	3,5	65	36	FLAT	6°	14°	2/9/100 + 2/9/110	DLI25M47PIH4	F03FS09631
	Dia Elővágo	200	4,7-5,5	3,5	65	36	FLAT	6°	14°	2/9/100 + 2/9/110	DLI25M47PIH6	F03FS09632
WN-WNA 750, WN-WNA 750 (PFS)	Fő-lap	470	4,8	3,5	70	72	TCG	15°	15°	4/11/130	LSB47005X	F03FS09185
	Fő-lap	520	4,8	3,5	70	72	TCG	15°	15°	4/11/130	LSB52006X	F03FS09193
	HW Elővágo	200	5,7-6,9	3,5	65	36	ATB	8°	15°	2/9/110	LI25M57PI3BS	F03FS08165
WN 600/145, WN 512	Fő-lap	480	4,8	3,5	80	72	TCG	15°	15°	2/9/130 + 4/19/120	LSB48001X	F03FS09188
	HW Elővágo	200	4,7-5,9	3,5	65	36	ATB	8°	15°	2/9/100 + 2/9/110	LI25M47PI3	F03FS02720
	Dia Elővágo	200	4,7-5,5	3,5	65	36	FLAT	6°	14°	2/9/100 + 2/9/110	DLI25M47PIH4	F03FS09631
	Dia Elővágo	200	4,7-5,5	3,5	65	36	FLAT	6°	14°	2/9/100 + 2/9/110	DLI25M47PIH6	F03FS09632
	Utófor. elővágo	300	4,55	3,2	65	72	ATB	15°	15°	2/9/100 + 2/9/110	LI27M DA3	F03FS02737
WNA600/162	Fő-lap	510	4,8	3,5	80	72	TCG	15°	15°	2/9/130 + 4/19/120	LSB51001X	F03FS09984
	HW Elővágo	200	4,7-5,9	3,5	65	36	ATB	8°	15°	2/9/100 + 2/9/110	LI25M47PI3	F03FS02720
	Dia Elővágo	200	4,7-5,5	3,5	65	36	FLAT	6°	14°	2/9/100 + 2/9/110	DLI25M47PIH4	F03FS09631
	Dia Elővágo	200	4,7-5,5	3,5	65	36	FLAT	6°	14°	2/9/100 + 2/9/110	DLI25M47PIH6	F03FS09632
	Utófor. elővágo	300	4,95	3	65	72	ATB	15°	15°	2/9/100 + 2/9/110	LI27M DB3	F03FS02739
WN-WNA 850	Fő-lap	600	5,8	4	70	60	TCG	15°	15°	4/11/130	LSB60004X	F03FS10258
	Fő-lap	600	5,8	4	75	60	TCG	15°	15°	4/6,5/130 + 4/11/130	LSB60006X	F03FS10259
	HW Elővágo	200	5,7-6,9	3,5	65	36	ATB	8°	15°	2/9/110	LI25M57PI3BS	F03FS08165



Gép-típus	Lap-típus	D	B-B1	b	d	Z	Fog-típus	α	β	ill. furatok	Freud kód	Cikksz.
		mm	mm	mm	mm							
<b>AES</b>												
ALPHA PS-03	Fő-lap	320	4,4	3,2	30	72	TCG	15°	15°	2/10/60 + 2/13/94	LSB32009X	F03FS10296
	HW Elövágó	200	4,3-5,5	3,2	20	36	ATB	8°	15°	2/10/60 + 2/9/62 + 2/11/66	LI25M43PA3	F03FS02670
ALPHA PS-05	Fő-lap	430	4,4	3,2	30	72	TCG	15°	15°	2/13/94	LSB43007X	F03FS09177
	HW Elövágó	200	4,3-5,5	3,2	20	36	ATB	8°	15°	2/11/66 + 2/10/60 + 2/9/62	LI25M43PA3	F03FS02670
ALPHA PS-06	Fő-lap	460	4,4	3,2	30	72	TCG	15°	15°	2/13/94	LSB46001X	F03FS08922
	HW Elövágó	200	4,3-5,5	3,2	20	36	ATB	8°	15°	2/11/66 + 2/10/60 + 2/9/62	LI25M43PA3	F03FS02670
<b>ANTHON</b>												
LN (90)	Fő-lap	400	4,4	3,2	60	72	TCG	15°	15°	2/14/100 + 2/11/85	LSB40017X	F03FS09272
	HW Elövágó	180	4,3-5,5	3,2	20	28	ATB	8°	15°	-	LI25M43NA3	F03FS02661
	HW Elövágó	180	4,3-5,5	3,2	20	36	ATB	8°	15°	-	LI25M43XA3	F03FS06372
PORTA 100	Fő-lap	400	4,4	3,2	60	72	TCG	15°	15°	2/14/100 + 2/11/85	LSB40017X	F03FS09272
	HW Elövágó	180	4,3-5,5	3,2	20	36	ATB	8°	15°	-	LI25M43XA3	F03FS06372
LNA (100), LN (120)	Fő-lap	450	4,4	3,2	60	72	TCG	15°	15°	2/14/125	LSB45008X	F03FS09182
	HW Elövágó	180	4,3-5,5	3,2	20	36	ATB	8°	15°	-	LI25M43XA3	F03FS06372
PORTA 150	Fő-lap	500	4,8	3,5	60	60	TCG	15°	15°	2/11/115	LSB50009X	F03FS09189
	HW Elövágó	180	4,3-5,5	3,2	20	36	ATB	8°	15°	-	LI25M43XA3	F03FS06372
<b>AYZA MIZRAK</b>												
LANZA P3	Fő-lap	320	4,4	3,2	65	60	TCG	15°	15°	2/9/110	LSB32003X	F03FS09161
	Fő-lap	320	4,4	3,2	65	72	TCG	15°	15°	2/9/95 + 2/9/110	LSB32001X	F03FS07805
	HW Elövágó	200	4,3-5,5	3,2	65	36	ATB	8°	15°	2/9/100 + 2/9/110	LI25M43PI3	F03FS02681
	Fő-lap	360	4,4	3,2	65	60	TCG	15°	15°	2/9/110	LSB36001X	F03FS10227
	Fő-lap	360	4,4	3,2	65	72	TCG	15°	15°	2/9/95 + 2/9/110	LSB36002X	F03FS07673
	HW Elövágó	200	4,3-5,5	3,2	65	36	ATB	8°	15°	2/9/100 + 2/9/110	LI25M43PI3	F03FS02681
	HW Elövágó	200	4,3-5,5	3,2	65	36	ATB	8°	15°	2/9/100 + 2/9/110	LI25M43PI3	F03FS02681
LANZA P4	Fő-lap	380	4,4	3,2	65	72	TCG	15°	15°	2/9/110	LSB38014X	F03FS09166
	HW Elövágó	200	4,3-5,5	3,2	65	36	ATB	8°	15°	2/9/100 + 2/9/110	LI25M43PI3	F03FS02681
LANZA P5	Fő-lap	400	4,4	3,2	65	72	TCG	15°	15°	2/9/110	LSB40016X	F03FS09172
	HW Elövágó	200	4,3-5,5	3,2	65	36	ATB	8°	15°	2/9/100 + 2/9/110	LI25M43PI3	F03FS02681
LANZA P5 CARRERA	Fő-lap	400	4,4	3,2	65	72	TCG	15°	15°	2/9/110	LSB40016X	F03FS09172
	HW Elövágó	200	4,3-5,5	3,2	65	36	ATB	8°	15°	2/9/100 + 2/9/110	LI25M43PI3	F03FS02681

AES - ANTHON  
AYZA MIZRAKELDER  
MAYER  
FIMAL  
GIBENHOLZER  
HOLZMAHOMAG  
NANXINGNIMAC  
SCHEER  
SCHELLINGSCM-GABBANI  
TÖRK MAKINE  
TURANLARLSB X RANGE  
BY DIAMETER

Gép- típus	Lap- típus	D	B-B1	b	d	Z	Fog- típus	$\alpha$	$\beta$	ill. furatok	Freud kód	Cikksz.
		mm	mm	mm	mm							
<b>FELDER MAYER</b>												
KAPPA AUTOMATIC 80	Fő- lap	320	4,4	3,2	30	60	TCG	15°	15°	2/10/60	LSB32005X	F03FS09160
	Fő- lap	320	4,4	3,2	30	72	TCG	15°	15°	2/10/60 + 2/13/94	LSB32009X	F03FS10296
KAPPA AUTOMATIC 80 EDITION	HW Elővágo	150	4,3-5,6	3,2	30	36	ATB	8°	15°	-	LI25M43KC3	F03FS02649
	Fő- lap	320	4,4	3,2	30	60	TCG	15°	15°	2/10/60	LSB32005X	F03FS09160
KAPPA AUTOMATIC CLASSIC	HW Elővágo	150	4,3-5,6	3,2	30	36	ATB	8°	15°	-	LI25M43KC3	F03FS02649
	Fő- lap	320	4,4	3,2	30	60	TCG	15°	15°	2/10/60	LSB32005X	F03FS09160
PS80	Fő- lap	320	4,4	3,2	30	60	TCG	15°	15°	2/10/60	LSB32005X	F03FS09160
	HW Elővágo	150	4,3-5,6	3,2	30	36	ATB	8°	15°	-	LI25M43KC3	F03FS02649
KAPPA AUTOMATIC 100	Fő- lap	355	4,4	3,2	30	72	TCG	15°	15°	2/10/60	LSB35504X	F03FS07674
	HW Elővágo	150	4,3-5,6	3,2	30	36	ATB	8°	15°	-	LI25M43KC3	F03FS02649
PS80 PREMIUM	Fő- lap	355	4,4	3,2	30	72	TCG	15°	15°	2/10/60	LSB35504X	F03FS07674
	HW Elővágo	150	4,3-5,6	3,2	30	36	ATB	8°	15°	-	LI25M43KC3	F03FS02649
KAPPA AUTOMATIC 120	Fő- lap	400	4,4	3,2	30	48	TCG	15°	15°	2/10/60	LSB40001X	F03FS09168
	Fő- lap	400	4,4	3,2	30	60	TCG	15°	15°	2/10/60	LSB40004X	F03FS09169
	Fő- lap	400	4,4	3,2	30	72	TCG	15°	15°	2/10/60 + 2/13/94	LSB40007X	F03FS07725
	HW Elővágo	150	4,3-5,6	3,2	30	36	ATB	8°	15°	-	LI25M43KC3	F03FS02649
PS100	Fő- lap	400	4,4	3,2	30	48	TCG	15°	15°	2/10/60	LSB40001X	F03FS09168
	Fő- lap	400	4,4	3,2	30	60	TCG	15°	15°	2/10/60	LSB40004X	F03FS09169
	Fő- lap	400	4,4	3,2	30	72	TCG	15°	15°	2/10/60 + 2/13/94	LSB40007X	F03FS07725
	HW Elővágo	150	4,3-5,6	3,2	30	36	ATB	8°	15°	-	LI25M43KC3	F03FS02649
PS2 Z	Fő- lap	450	4,4	3,2	30	72	TCG	15°	15°	2/10/60 + 2/14/95	LSB45007X	F03FS09181
	HW Elővágo	150	4,3-5,6	3,2	30	36	ATB	8°	15°	-	LI25M43KC3	F03FS02649
KAPPA AUTOMATIC 140	Fő- lap	450	4,4	3,2	30	72	TCG	15°	15°	2/10/60 + 2/14/95	LSB45007X	F03FS09181
	HW Elővágo	150	4,3-5,6	3,2	30	36	ATB	8°	15°	-	LI25M43KC3	F03FS02649
<b>FIMAL</b>												
CONCEPT 350	Fő- lap	350	4,4	3,2	30	72	TCG	15°	15°	2/10/60	LSB35003X	F03FS07630
	Fő- lap	300	4,4	3	30	60	TCG	15°	15°	2/10/60	LSB30001X	F03FS07802
KR32	Fő- lap	350	4,4	3,2	30	72	TCG	15°	15°	2/10/60	LSB35003X	F03FS07630
KR43	Fő- lap	350	4,4	3,2	30	72	TCG	15°	15°	2/10/60	LSB35003X	F03FS07630

Gép-típus	Lap-típus	D	B-B1	b	d	Z	Fog-típus	α	β	ill. furatok	Freud kód	Cikksz.
		mm	mm	mm	mm							
<b>GIBEN</b>												
MK, GAMMA, N, ST, SE, TREND	Fő-lap	355	4,4	3,2	75	72	TCG	15°	15°	4/15/105 + 2/7/110	LSB35505X	F03FS07633
	HW Elövágó	125	4,3-5,5	3,2	45	24	ATB	0°	15°	-	LI25M43FE3	F03FS02645
SMART SP105, ICON 105	Fő-lap	380	4,4	3,2	50	72	TCG	15°	15°	4/13/80	LSB38008X	F03FS09165
	HW Elövágó	250	4,3-5,5	3,2	50	48	ATB	8°	15°	3/13/80	LI25M430F3	F03FS02669
G 2000 STARMATIC	Fő-lap	400	4,4	3,2	75	72	TCG	15°	15°	4/15/105 + 2/7/110 + 2/14/100	LSB40008X	F03FS07726
	Fő-lap	400	4,4	3,2	75	84	TCG	15°	15°	4/15/105 + 2/7/110	LSB40019X	F03FS08990
	HW Elövágó	125	4,5-5,7	3	45	24	ATB	0°	15°	-	LI25M45FE3	F03FS02699
	Fő-lap	400	4,4	3,2	75	72	TCG	15°	15°	4/15/105 + 2/7/110 + 2/14/100	LSB40008X	F03FS07726
PRISMATIC 101	HW Elövágó	160	4,3-5,5	3,2	45	36	ATB	8°	15°	03/11/70	LI25M43LE3	F03FS02655
	Fő-lap	400	4,4	3,2	75	72	TCG	15°	15°	4/15/105 + 2/7/110 + 2/14/100	LSB40008X	F03FS07726
	Fő-lap	430	4,4	3,2	75	72	TCG	15°	15°	4/15/105 + 2/7/110	LSB43008X	F03FS07908
	HW Elövágó	215	4,3-5,5	3,2	50	42	ATB	8°	15°	2/7/80 + 3/15/80	LI25M430F3	F03FS02685
PRISMATIC 201	HW Elövágó	300	4,3-5,5	3,5	50	48	ATB	12°	15°	3/15/80	LI25M43RM3	F03FS02693
	Dia Elövágó	215	4,3-5,1	3,2	50	42	FLAT	6°	14°	2/7/80 + 3/15/80	DLI25M43QFH4	F03FS09633
	Dia Elövágó	215	4,3-5,1	3,2	50	42	FLAT	6°	14°	2/7/80 + 3/15/80	DLI25M43QFH6	F03FS09634
	Utófor. Elövágó	300	4,55	3,2	50	72	ATB	15°	15°	3/15/80	LI27M DD3	F03FS02743
	Fő-lap	470	4,4	3,2	75	96	TCG	15°	15°	4/15/105	LSB47004X	F03FS09184
	HW Elövágó	215	4,3-5,5	3,2	50	42	ATB	8°	15°	2/7/80 + 3/15/80	LI25M430F3	F03FS02685
	HW Elövágó	215	4,5-5,7	3,2	50	42	ATB	8°	15°	3/15/80	LI25M45PF3	F03FS02713
	HW Elövágó	300	4,3-5,5	3,5	50	48	ATB	12°	15°	3/15/80	LI25M43RM3	F03FS02693
PRISMATIC 2, 3	Dia Elövágó	215	4,3-5,1	3,2	50	42	FLAT	6°	14°	2/7/80 + 3/15/80	DLI25M43QFH4	F03FS09633
	Dia Elövágó	215	4,3-5,1	3,2	50	42	FLAT	6°	14°	2/7/80 + 3/15/80	DLI25M43QFH6	F03FS09634
	Utófor. Elövágó	300	4,55	3,2	50	72	ATB	15°	15°	3/15/80	LI27M DD3	F03FS02743
	Fő-lap	530	4,8	3,5	75	72	TCG	15°	15°	2/7/110	LSB53004X	F03FS09651
ICONFAST LM D-816	HW Elövágó	215	4,7-5,9	3,5	50	42	ATB	8°	15°	2/7/80	LI25M47QF3	F03FS09650

FELDER  
MAYER  
GIBEN

HOLZER  
HOLZMA

HOMAG  
NANXING

NIMAC  
SCHEER  
SCHELLING

SCM-GABRIANI  
TÖRK MAKINE  
TURANLAR

LSB X RANGE  
BY DIAMETER

Gép-típus	Lap-típus	D mm	B-B1 mm	b mm	d mm	Z	Fog-típus	$\alpha$	$\beta$	ill. furatok	Freud kód	Cikksz.
<b>HOLZHER</b>												
<b>CUT 85, 82</b>	Fő-lap	350	4,4	3,2	30	72	TCG	15°	15°	2/10/60	LSB35003X	F03FS07630
	HW Elővágó	180	4,3-5,5	3,2	30	28	ATB	8°	15°	2/7/42 + 2/10/60	LI25M43NC3	F03FS02663
	HW Elővágó	180	4,3-5,5	3,2	30	36	ATB	8°	15°	2/7/42 + 2/10/60	LI25M43XN3	F03FS06373
	Utófor. elővágó	250	4,6	3,0	30	48	ATB	15°	15°	-	LI27M BA3	F03FS02734
<b>TECTRA 6120 CLASSIC</b>	Fő-lap	350	4,4	3,2	30	72	TCG	15°	15°	2/10/60	LSB35003X	F03FS07630
	HW Elővágó	180	4,3-5,5	3,2	30	36	ATB	8°	15°	2/7/42 + 2/10/60	LI25M43XN3	F03FS06373
<b>CUT 110</b>	Fő-lap	400	4,4	3,2	30	72	TCG	15°	15°	2/10/60 + 2/13/94	LSB40007X	F03FS07725
	HW Elővágó	250	4,3-5,5	3,2	30	48	CON	8°	15°	2/10/60	LI25M43OC3	F03FS02668
	Utófor. elővágó	250	4,6	3,0	30	48	ATB	15°	15°	-	LI27M BA3	F03FS02734
<b>ZENTREX 6220 (POWER, LIFT, DYNAMIC)</b>	Fő-lap	430	4,4	3,2	30	72	TCG	15°	15°	2/13/94	LSB43007X	F03FS09177
	HW Elővágó	180	4,3-5,5	3,2	30	36	ATB	8°	15°	2/7/42 + 2/10/60	LI25M43XN3	F03FS06373
<b>HOLZMA</b>												
<b>HPP130</b>	Fő-lap	300	4,4	3,2	60	72	TCG	15°	15°	2/14/100	LSB30012X	F03FS09207
	Dia Elővágó	180	4,3-5,1	3,2	45	30	FLAT	6°	14°	-	DLI25M43NEH4	F03FS09621
	Dia Elővágó	180	4,3-5,1	3,2	45	30	FLAT	6°	14°	-	DLI25M43NEH6	F03FS09622
	HW Elővágó	180	4,3-5,5	3,2	45	36	CON	8°	15°	-	LI25M43NE3	F03FS02664
<b>HPP230, 250 (2014.06. hó előtt)</b>	Fő-lap	300	4,4	3,2	60	72	TCG	15°	15°	2/14/100	LSB30012X	F03FS09207
	Fő-lap	350	4,4	3,2	60	72	TCG	15°	15°	2/14/100	LSB35004X	F03FS07636
	HW Elővágó	200	4,3-5,5	3,2	45	36	ATB	8°	15°	-	LI25M43PE3	F03FS02676
	HW Elővágó	180	4,3-5,5	3,2	45	36	ATB	8°	15°	-	LI25M43NE3	F03FS02664
	Dia Elővágó	180	4,3-5,1	3,2	45	30	FLAT	6°	14°	-	DLI25M43NEH4	F03FS09621
	Dia Elővágó	180	4,3-5,1	3,2	45	30	FLAT	6°	14°	-	DLI25M43NEH6	F03FS09622
<b>SAWTEQ B-200</b>	Fő-lap	310	4,4	3,2	60	72	TCG	15°	15°	2/14/100	LSB31001X	F03FS09949
	HW Elővágó	200	4,3-5,5	3,2	45	36	ATB	8°	15°	-	LI25M43PE3	F03FS02676
<b>HPP350</b>	MFő lap	350	4,4	3,2	75	72	TCG	15°	15°	-	LSB35008X	F03FS07634
	HW Elővágó	180	4,3-5,5	3,2	45	36	ATB	8°	15°	-	LI25M43NE3	F03FS02664
	Dia Elővágó	180	4,3-5,1	3,2	45	30	FLAT	6°	14°	-	DLI25M43NEH4	F03FS09621
	Dia Elővágó	180	4,3-5,1	3,2	45	30	FLAT	6°	14°	-	DLI25M43NEH6	F03FS09622

Gép-típus	Lap-típus	D	B-B1	b	d	Z	Fog-típus	$\alpha$	$\beta$	ill. furatok	Freud kód	Cikksz.
		mm	mm	mm	mm							
HPP180	Fő-lap	380	4,4	3,2	60	72	TCG	15°	15°	2/14/100	LSB38002X	F03FS07631
	HW Elövágó	180	4,3-5,5	3,2	45	36	ATB	8°	15°	-	LI25M43NE3	F03FS02664
	Dia Elövágó	180	4,3-5,1	3,2	45	30	FLAT	6°	14°	-	DLI25M43NEH4	F03FS09621
	Dia Elövágó	180	4,3-5,1	3,2	45	30	FLAT	6°	14°	-	DLI25M43NEH6	F03FS09622
HPP380, 82	Fő-lap	380	4,4	3,2	60	72	TCG	15°	15°	2/14/100	LSB38002X	F03FS07631
	Fő-lap	380	4,8	3,5	60	72	TCG	15°	15°	2/14/100	LSB38004X	F03FS07632
	Fő-lap	380	4,8	3,5	60	84	TCG	15°	15°	2/14/100	LSB38005X	F03FS07807
	HW Elövágó	180	4,3-5,5	3,2	45	36	ATB	8°	15°	-	LI25M43NE3	F03FS02664
	HW Elövágó	180	4,7-5,9	3,5	45	36	ATB	8°	15°	-	LI25M47NE3	F03FS02715
	Dia Elövágó	180	4,3-5,1	3,2	45	30	FLAT	6°	14°	-	DLI25M43NEH4	F03FS09621
	Dia Elövágó	180	4,3-5,1	3,2	45	30	FLAT	6°	14°	-	DLI25M43NEH6	F03FS09622
	Dia Elövágó	180	4,7-5,5	3,5	45	30	FLAT	6°	14°	-	DLI25M47NEH4	F03FS09623
	Dia Elövágó	180	4,7-5,5	3,5	45	30	FLAT	6°	14°	-	DLI25M47NEH6	F03FS09624
	Utófor. elövágó	280	5,0	3,5	45	84	ATB	15°	15°	-	LI27M CA3	F03FS02736
HPL410	Fő-lap	420	4,8	3,5	60	60	TCG	15°	15°	2/14/125	LSB42001X	F03FS10234
	Fő-lap	420	4,8	3,5	60	84	TCG	15°	15°	2/14/100 + 2/14/125	LSB42002X	F03FS09176
	HW Elövágó	180	4,7-5,9	3,5	45	36	ATB	8°	15°	-	LI25M47NE3	F03FS02715
	Dia Elövágó	180	4,7-5,5	3,5	45	30	FLAT	6°	14°	-	DLI25M47NEH4	F03FS09623
	Dia Elövágó	180	4,7-5,5	3,5	45	30	FLAT	6°	14°	-	DLI25M47NEH6	F03FS09624
	Utófor. elövágó	340	5,0	3,5	45	108	ATB	15°	15°	3/14/65	LI27M EB3	F03FS02747
HPP430, 510, 11	Fő-lap	450	4,8	3,5	60	72	TCG	15°	15°	2/14/125 + 2/17/100	LSB45017X	F03FS07391
	HW Elövágó	180	4,7-5,9	3,5	45	36	ATB	8°	15°	-	LI25M47NE3	F03FS02715
	Dia Elövágó	180	4,7-5,5	3,5	45	30	FLAT	6°	14°	-	DLI25M47NEH4	F03FS09623
	Dia Elövágó	180	4,7-5,5	3,5	45	30	FLAT	6°	14°	-	DLI25M47NEH6	F03FS09624
	Utófor. elövágó	340	5,0	3,5	45	108	ATB	15°	15°	3/14/65	LI27M EB3	F03FS02747

HOLZER  
HOLZMA

HOMAG  
NANXING

NIMAC  
SCHEER  
SCHELLING

SCM-GABRIANI  
TÖRK MAKINE  
TURANLAR

LSB X RANGE  
BY DIAMETER

Gép-típus	Lap-típus	D	B-B1	b	d	Z	Fog-típus	$\alpha$	$\beta$	ill. furatok	Freud kód	Cikksz.
		mm	mm	mm	mm							
22	Fő-lap	500	4,8	3,5	60	72	TCG	15°	15°	2/11/115	LSB50011X	F03FS09191
	HW Elővágo	200	4,7-5,9	3,5	45	36	ATB	8°	15°	-	LI25M47PE3	F03FS02719
	Dia Elővágo	200	4,7-5,5	3,5	45	36	FLAT	6°	14°	-	DLI25M47PEH4	F03FS09629
	Dia Elővágo	200	4,7-5,5	3,5	45	36	FLAT	6°	14°	-	DLI25M47PEH6	F03FS09630
	Utófor. elővágo	340	5,0	3,5	45	108	ATB	15°	15°	3/14/65	LI27M EB3	F03FS02747
HPL550	Fő-lap	520	4,8	3,5	60	72	TCG	15°	15°	2/11/115 + 2/19/120	LSB52003X	F03FS09192
	HW Elővágo	200	4,7-5,9	3,5	45	36	ATB	8°	15°	-	LI25M47PE3	F03FS02719
	Dia Elővágo	200	4,7-5,5	3,5	45	36	FLAT	6°	14°	-	DLI25M47PEH4	F03FS09629
	Dia Elővágo	200	4,7-5,5	3,5	45	36	FLAT	6°	14°	-	DLI25M47PEH6	F03FS09630
	Utófor. elővágo	340	5,0	3,5	45	108	ATB	15°	15°	3/14/65	LI27M EB3	F03FS02747
HPL570	Fő-lap	570	4,8	3,5	60	60	TCG	15°	15°	2/11/115 + 2/19/120	LSB57001X	F03FS09199
	HW Elővágo	200	4,7-5,9	3,5	45	36	ATB	8°	15°	-	LI25M47PE3	F03FS02719
	DP Elővágo	200	4,7-5,5	3,5	45	36	FLAT	6°	14°	-	DLI25M47PEH4	F03FS09629
	DP Elővágo	200	4,7-5,5	3,5	45	36	FLAT	6°	14°	-	DLI25M47PEH6	F03FS09630
	Utófor. elővágo	340	5,0	3,5	45	108	ATB	15°	15°	3/14/65	LI27M EB3	F03FS02747
HPP42, 33	Fő-lap	600	5,8	4	60	60	TCG	15°	15°	2/11/115 + 2/19/120	LSB60001X	F03FS09200
	Fő-lap	600	5,8	4	60	72	TCG	15°	15°	2/11/115 + 2/19/120	LSB60002X	F03FS09201
	HW Elővágo	200	5,7-6,9	4	45	36	ATB	8°	15°	-	LI25M57PE3	F03FS02728
<b>HOMAG</b>												
CH 3	Fő-lap	300	4,4	3	75	60	TCG	15°	15°	-	LSB30003X	F03FS03916
	HW Elővágo	125	4,3-5,5	3,2	45	24	ATB	0°	15°	-	LI25M43FE3	F03FS02645
CH 3	Fő-lap	300	4,4	3	75	60	TCG	15°	15°	-	LSB30003X	F03FS03916
	HW Elővágo	125	4,3-5,5	3,2	45	24	ATB	0°	15°	-	LI25M43FE3	F03FS02645
CT 04/40	Fő-lap	300	4,4	3	75	60	TCG	15°	15°	-	LSB30003X	F03FS03916
	HW Elővágo	150	4,3-5,6	3,2	45	36	ATB	8°	15°	-	LI25M43KE3	F03FS02651
CV'S	Fő-lap	300	4,4	3	75	60	TCG	15°	15°	-	LSB30003X	F03FS10218
	HW Elővágo	125	4,3-5,5	3,2	45	24	ATB	0°	15°	-	LI25M43FE3	F03FS02645

Gép-típus	Lap-típus	D	B-B1	b	d	Z	Fog-típus	α	β	ill. furatok	Freud kód	Cikksz.
		mm	mm	mm	mm							
CH 04	Fő-lap	355	4,4	3,2	75	72	TCG	15°	15°	3/7/100	LSB35507X	F03FS07710
	HW Elövágó	180	4,3-5,5	3,2	45	36	ATB	8°	15°	-	LI25M43NE3	F03FS02664
	Dia Elövágó	180	4,3-5,1	3,2	45	30	FLAT	6°	14°	-	DLI25M43NEH4	F03FS09621
	Dia Elövágó	180	4,3-5,1	3,2	45	30	FLAT	6°	14°	-	DLI25M43NEH6	F03FS09622
CH 08/12	Fő-lap	400	4,4	3,2	75	72	TCG	15°	15°	4/15/105 + 2/7/110 + 2/14/100	LSB40008X	F03FS07726
	HW Elövágó	150	4,3-5,6	3,2	45	36	ATB	8°	15°	-	LI25M43KE3	F03FS02651
<b>NANXING</b>												
NPC330	Fő-lap	380	4,4	3,2	60	72	TCG	15°	15°	2/14/100	LSB38002X	F03FS07631
	Fő-lap	350	4,4	3,2	60	72	TCG	15°	15°	2/14/100	LSB35004X	F03FS07636
	HW Elövágó	200	4,3-5,5	3,2	45	36	ATB	8°	15°	-	LI25M43PE3	F03FS02676
MJB1327B	Fő-lap	450	4,8	3,5	60	72	TCG	15°	15°	2/14/125 + 2/17/100	LSB45017X	F03FS09272
	Fő-lap	400	4,4	3,2	60	84	TCG	15°	15°	2/14/100	LSB40021X	F03FS09255
	HW Elövágó	180	4,3-5,5	3,2	30	36	ATB	8°	15°	2/7/42 + 2/10/60	LI25M43XN3	F03FS06373
NP280FG NP280F	Fő-lap	450	4,8	3,5	60	72	TCG	15°	15°	2/14/125 + 2/17/100	LSB45017X	F03FS09272
	Fő-lap	400	4,4	3,2	60	84	TCG	15°	15°	2/14/100	LSB40021X	F03FS09255
	Fő-lap	350	4,4	3,2	60	72	TCG	15°	15°	2/14/100	LSB35004X	F03FS07636
	HW Elövágó	180	4,3-5,5	3,2	30	36	ATB	8°	15°	2/7/42 + 2/10/60	LI25M43XN3	F03FS06373
NPL330HG NP330H NP330HG	Fő-lap	450	4,8	3,5	60	72	TCG	15°	15°	2/14/125 + 2/17/100	LSB45017X	F03FS07391
	HW Elövágó	180	4,7-5,9	3,5	45	36	ATB	8°	15°	-	LI25M47NE3	F03FS02715
	Dia Elövágó	180	4,7-5,5	3,5	45	30	FLAT	6°	14°	-	DLI25M47NEH4	F03FS09623
NP330FG NP330FG NP330F	Dia Elövágó	180	4,7-5,5	3,5	45	30	FLAT	6°	14°	-	DLI25M47NEH6	F03FS09624
	Fő-lap	450	4,8	3,5	60	72	TCG	15°	15°	2/14/125 + 2/17/100	LSB45017X	F03FS09272
	Fő-lap	400	4,4	3,2	60	84	TCG	15°	15°	2/14/100	LSB40021X	F03FS09255
	HW Elövágó	180	4,7-5,9	3,5	45	36	ATB	8°	15°	-	LI25M47NE3	F03FS02715
	Dia Elövágó	180	4,7-5,5	3,5	45	30	FLAT	6°	14°	-	DLI25M47NEH4	F03FS09623
	Dia Elövágó	180	4,7-5,5	3,5	45	30	FLAT	6°	14°	-	DLI25M47NEH6	F03FS09624

HOMAG  
NANXING

HIMAC  
PANHANS  
HEER  
SCHELLING

SCM-GABBANI  
TORK  
MAKINE  
TURANLAR

LSB X RANGE  
BY DIAMETER

Gép-típus	Lap-típus	D	B-B1	b	d	Z	Fog-típus	$\alpha$	$\beta$	ill. furatok	Freud kód	Cikksz.
		mm	mm	mm	mm							
NZH3318 NPD380	Fő-lap	450	4,8	3,5	60	72	TCG	15°	15°	2/14/125 + 2/17/100	LSB45017X	F03FS07391
	HW Elővágo	180	4,7-5,9	3,5	45	36	ATB	8°	15°	-	LI25M47NE3	F03FS02715
	Dia Elővágo	180	4,7-5,5	3,5	45	30	FLAT	6°	14°	-	DLI25M47NEH4	F03FS09623
	Dia Elővágo	180	4,7-5,5	3,5	45	30	FLAT	6°	14°	-	DLI25M47NEH6	F03FS09624
<b>NIMAC</b>												
HERMES 70 CNC	Fő-lap	300	4,4	3	65	72	TCG	15°	15°	2/9/95 + 2/9/110	LSB30006X	F03FS09158
	Fő-lap	320	4,4	3,2	65	72	TCG	15°	15°	2/9/95 + 2/9/110	LSB32001X	F03FS07805
ATLAS 80	Fő-lap	320	4,4	3,2	65	72	TCG	15°	15°	2/9/95 + 2/9/110	LSB32001X	F03FS07805
ATLAS 100/100TL	Fő-lap	355	4,4	3,2	65	72	TCG	15°	15°	2/9/95 + 2/9/110	LSB35508X	F03FS08740
	Fő-lap	360	4,4	3,2	65	72	TCG	15°	15°	2/9/95 + 2/9/110	LSB36002X	F03FS07673
<b>PANHANS</b>												
EURO 10 SF	Fő-lap	300	4,4	3	30	60	TCG	15°	15°	2/10/60	LSB30001X	F03FS07802
	HW Elővágo	250	4,3-5,5	3,2	30	48	CON	8°	15°	2/10/60	LI25M430C3	F03FS02668
	Utófor. elővágo	250	4,6	3	30	48	ATB	15°	15°	-	LI27M BA3	F03FS02734
EURO 5 (SF, COMPACT, ECOPAN)	Fő-lap	300	4,4	3	30	60	TCG	15°	15°	2/10/60	LSB30001X	F03FS07802
	HW Elővágo	125	4,3-5,5	3,2	20	24	CON	0°	15°	-	LI25M43FA3	F03FS02643
EURO10, 693/SH 70	Fő-lap	300	4,4	3	30	60	TCG	15°	15°	2/10/60	LSB30001X	F03FS07802
	HW Elővágo	125	4,3-5,5	3,2	20	24	CON	0°	15°	-	LI25M43FA3	F03FS02643
	HW Elővágo	180	4,3-5,5	3,2	30	28	CON	8°	15°	2/7/42 + 2/10/60	LI25M43NC3	F03FS02663
S 45	Fő-lap	300	4,4	3	30	60	TCG	15°	15°	2/10/60	LSB30001X	F03FS07802
	Fő-lap	350	4,4	3,2	30	72	TCG	15°	15°	2/10/60	LSB35003X	F03FS07630
	HW Elővágo	180	4,3-5,5	3,2	30	28	CON	8°	15°	2/7/42 + 2/10/60	LI25M43NC3	F03FS02663
EURO 12, 30	Fő-lap	350	4,4	3,2	30	72	TCG	15°	15°	2/10/60	LSB35003X	F03FS07630
	HW Elővágo	180	4,3-5,5	3,2	30	28	CON	8°	15°	2/7/42 + 2/10/60	LI25M43NC3	F03FS02663
EURO 12 SF	Fő-lap	350	4,4	3,2	30	72	TCG	15°	15°	2/10/60	LSB35003X	F03FS07630
	HW Elővágo	280	4,3-5,5	3,2	30	48	CON	12°	15°	2/10/60	LI25M43VC3	F03FS07419
POLYPAN 47	Main blade	350	4,4	3,2	30	72	TCG	15°	15°	2/10/60	LSB35003X	F03FS07630
	HW Elővágo	180	4,3-5,5	3,2	30	28	CON	8°	15°	2/7/42 + 2/10/60	LI25M43NC3	F03FS02663
	Utófor. elővágo	300	4,55	3	30	72	ATB	15°	15°	-	LI27M DF3	F03FS02745



Gép-típus	Lap-típus	D	B-B1	b	d	Z	Fog-típus	$\alpha$	$\beta$	ill. furatok	Freud kód	Cikksz.
		mm	mm	mm	mm							
EUROSTAR 2 XL, POLYSTAR	Fő-lap	370	4,4	3,2	30	72	TCG	15°	15°	2/10/60	LSC37001	F03FS06312
	HW Elővágo	180	4,3-5,5	3,2	30	28	CON	8°	15°	2/7/42 + 2/10/60	LI25M43NC3	F03FS02663
	HW Elővágo	280	4,3-5,5	3,2	30	48	CON	6°	15°	2/10/60	LI25M43VC3	F03FS07419
EURO 32	Fő-lap	370	4,4	3,2	30	72	TCG	15°	15°	2/10/60	LSB37001X	F03FS10228
	HW Elővágo	180	4,3-5,5	3,2	30	28	CON	8°	15°	2/7/42 + 2/10/60	LI25M43NC3	F03FS02663
693/SH 110	Fő-lap	400	4,4	3,2	30	72	TCG	15°	15°	2/10/60 + 2/13/94	LSB40007X	F03FS07725
	HW Elővágo	180	4,3-5,5	3,2	30	28	CON	8°	15°	2/7/42 + 2/10/60	LI25M43NC3	F03FS02663
EUROSTAR 2 XXL	Fő-lap	400	4,4	3,2	30	72	TCG	15°	15°	2/10/60 + 2/13/94	LSB40007X	F03FS07725
	HW Elővágo	180	4,3-5,5	3,2	30	28	CON	8°	15°	2/7/42 + 2/10/60	LI25M43NC3	F03FS02663
	HW Elővágo	280	4,3-5,5	3,2	30	48	CON	6°	15°	2/10/60	LI25M43VC3	F03FS07419
<b>SCHEER KOCH</b>												
PA 6000, 5500	MFő- blap	350	4,4	3,2	30	72	TCG	15°	15°	2/10/60	LSB35003X	F03FS07630
	HW Elővágo	200	4,3-5,5	3,2	20	36	ATB	8°	15°	2/11/66 + 2/10/60 + 2/9/62	LI25M43PA3	F03FS02670
	HW Elővágo	200	4,3-5,5	3,2	30	36	ATB	8°	15°	2/9/60 + 2/10/60	LI25M43PC3	F03FS02674
<b>SHELLING</b>												
FH3	Fő-lap	300	4,4	3	30	72	TCG	15°	15°	2/10/60	LSB30005X	F03FS07803
	Fő-lap	350	4,4	3,2	30	72	TCG	15°	15°	2/10/60	LSB35003X	F03FS07630
	HW Elővágo	180	4,3-5,5	3,2	30	36	ATB	8°	15°	2/7/42 + 2/10/60	LI25M43XN3	F03FS06373
FH4 (2015.06-ig)	Fő- blap	350	4,4	3,2	30	72	TCG	15°	15°	2/10/60	LSB35003X	F03FS07630
	HW Elővágo	300	4,3-5,5	3,2	30	48	ATB	12°	15°	2/11/73 + 2/11/75 + 2/13/94	LI25M43RC3	F03FS07577
S45	Fő-lap	350	4,4	3,2	30	72	TCG	15°	15°	2/10/60	LSB35003X	F03FS07630
	Fő-lap	400	4,4	3,2	30	72	TCG	15°	15°	2/10/60 + 2/13/94	LSB40007X	F03FS07725
	HW Elővágo	180	4,3-5,5	3,2	30	36	ATB	8°	15°	2/7/42 + 2/10/60	LI25M43XN3	F03FS06373
SCHELLING FH4 (2015.07-től 2017.07-ig)	HW Elővágo	300	4,3-5,5	3,2	30	48	ATB	12°	15°	2/11/73 + 2/11/75 + 2/13/94	LI25M43RC3	F03FS07577
	Fő-lap	360	4,4	3,2	30	72	TCG	15°	15°	2/13/94	LSB36003X	F03FS09341
FH4 (2017.07-től)	HW Elővágo	200	4,3-5,5	3,2	20	36	ATB	8°	15°	2/11/66 + 2/10/60 + 2/9/62	LI25M43PA3	F03FS02670
	Fő-lap	360	4,4	3,2	30	72	TCG	15°	15°	2/13/94	LSB36003X	F03FS09341
FH5 (2015.07-től)	HW Elővágo	300	4,3-5,5	3,2	30	48	ATB	12°	15°	2/11/73 + 2/11/75 + 2/13/94	LI25M43RC3	F03FS07577
	Fő-lap	400	4,4	3,2	30	72	TCG	15°	15°	2/10/60 + 2/13/94	LSB40007X	F03FS07725
FH5 (2015.07-től)	HW Elővágo	300	4,3-5,5	3,2	30	48	ATB	12°	15°	2/11/73 + 2/11/75 + 2/13/94	LI25M43RC3	F03FS07577

Gép-típus	Lap-típus	D	B-B1	b	d	Z	Fog-típus	$\alpha$	$\beta$	ill. furatok	Freud kód	Cikksz.
		mm	mm	mm	mm							
<b>FH5</b> (2015.07-től)	Fő-lap	400	4,4	3,2	30	72	TCG	15°	15°	2/10/60 + 2/13/94	<b>LSB40007X</b>	F03FS07725
	HW Elővágó	300	4,3-5,5	3,2	30	48	ATB	12°	15°	2/11/73 + 2/11/75 + 2/13/94	<b>LI25M43RC3</b>	F03FS07577
<b>FH5</b>	Fő-lap	400	4,4	3,2	30	72	TCG	15°	15°	2/10/60 + 2/13/94	<b>LSB40007X</b>	F03FS07725
	HW Elővágó	200	4,3-5,5	3,2	20	36	ATB	8°	15°	2/11/66 + 2/10/60 + 2/9/62	<b>LI25M43PA3</b>	F03FS02670
<b>FK4</b> (2015.07-től)	Fő-lap	400	4,4	3,2	30	72	TCG	15°	15°	2/10/60 + 2/13/94	<b>LSB40007X</b>	F03FS07725
	HW Elővágó	200	4,3-5,5	3,2	20	36	ATB	8°	15°	2/11/66 + 2/10/60 + 2/9/62	<b>LI25M43PA3</b>	F03FS02670
<b>FK4</b> (2017.07-től)	Fő-lap	400	4,4	3,2	30	72	TCG	15°	15°	2/10/60 + 2/13/94	<b>LSB40007X</b>	F03FS07725
	HW Elővágó	300	4,3-5,5	3,2	30	48	ATB	12°	15°	2/11/73 + 2/11/75 + 2/13/94	<b>LI25M43RC3</b>	F03FS07577
<b>FH6, AH6, CH6</b> (2015.06-ig)	Fő-lap	460	4,4	3,2	30	72	TCG	15°	15°	2/13/94	<b>LSB46001X</b>	F03FS08922
	HW Elővágó	200	4,3-5,5	3,2	20	36	ATB	8°	15°	2/11/66 + 2/10/60 + 2/9/62	<b>LI25M43PA3</b>	F03FS02670
<b>FK6, FP6, FM6</b>	Fő-lap	460	4,4	3,2	30	72	TCG	15°	15°	2/13/94	<b>LSB46001X</b>	F03FS08922
	HW Elővágó	200	4,3-5,5	3,2	20	36	ATB	8°	15°	2/11/66 + 2/10/60 + 2/9/62	<b>LI25M43PA3</b>	F03FS02670
<b>FH6, AH6, CH6</b> (2015.07-től kezdődően)	Fő-lap	480	4,8	3,5	30	72	TCG	15°	15°	2/10/60 + 2/13/94	<b>LSB48004X</b>	F03FS09187
	HW Elővágó	220	4,7-5,9	3,5	20	36	ATB	8°	15°	2/9/62	<b>LI25M47UA3</b>	F03FS09266
	HW Elővágó	200	4,7-5,9	3,5	20	36	ATB	8°	15°	2/11/66	<b>LI25M47PA3</b>	F03FS02716
<b>FL</b>	Fő-lap	480	4,4	3,2	30	72	TCG	15°	15°	2/10/60 + 2/13/94	<b>LSB48007X</b>	F03FS09914
	HW Elővágó	200	4,3-5,5	3,2	20	36	ATB	8°	15°	2/11/66 + 2/10/60 + 2/9/62	<b>LI25M43PA3</b>	F03FS02670
<b>FH8, AH8, CH8</b>	Fő-lap	520	4,8	3,5	30	72	TCG	15°	15°	2/13/94	<b>LSB52007X</b>	F03FS09319
	Fő-lap	520	4,4	3,2	30	72	TCG	15°	15°	2/13/94	<b>LSB52008X</b>	F03FS09319
	HW Elővágó	200	4,3-5,5	3,2	20	36	ATB	8°	15°	2/11/66 + 2/10/60 + 2/9/62	<b>LI25M43PA3</b>	F03FS02670
	HW Elővágó	220	4,7-5,9	3,5	20	36	ATB	8°	15°	2/9/62	<b>LI25M47UA3</b>	F03FS09266
	HW Elővágó	200	4,7-5,9	3,5	20	36	ATB	8°	15°	2/11/66	<b>LI25M47PA3</b>	F03FS02716
<b>FK8, FM8</b>	Fő-lap	520	4,8	3,5	30	72	TCG	15°	15°	2/13/94	<b>LSB52007X</b>	F03FS09319
	HW Elővágó	200	4,7-5,9	3,5	20	36	ATB	8°	15°	2/11/66	<b>LI25M47PA3</b>	F03FS02716
	Fő-lap	520	4,4	3,2	30	72	TCG	15°	15°	2/13/94	<b>LSB52008X</b>	F03FS09319
	HW Elővágó	200	4,3-5,5	3,2	20	36	ATB	8°	15°	2/11/66 + 2/10/60 + 2/9/62	<b>LI25M43PA3</b>	F03FS02670
<b>FK10, FM10</b>	Fő-lap	680	6,2	4,2	40	60	TCG	18°	13°	2/13/140 + 2/17/140 + 2/13/114	<b>LSB68001X</b>	F03FS09203
	HW Elővágó	200	6,1-7,3	4	20	36	ATB	8°	15°	2/11/66	<b>LI25M61PA3</b>	F03FS02730
<b>ASH (FSM)</b>	Fő-lap	720	6,4	4,4	40	60	TCG	18°	13°	2/14/114 + 2/14/140	<b>LSB72001X</b>	F03FS09204
	HW Elővágó	220	6,3-7,5	4,4	20	36	ATB	8°	15°	2/11/66	<b>LI25M63UA3</b>	F03FS02732

Gép-típus	Lap-típus	D	B-B1	b	d	Z	Fog-típus	α	β	ill. furatok	Freud kód	Cikksz.
		mm	mm	mm	mm							
<b>SCM</b>												
PRIMA 50	Fő-lap	300	4,4	3	80	60	TCG	15°	15°	4/9/100 + 2/14/110	LSB30004X	F03FS09157
	Fő-lap	300	4,4	3	80	72	TCG	15°	15°	4/9/100 + 2/14/110	LSB30008X	F03FS07804
PRIMA 67	HW Elővágo	160	4,3-5,5	3,2	55	36	ATB	8°	15°	3/6/84 + 3/7/66	LI25M43LG3	F03FS02657
	Fő-lap	320	4,4	3,2	80	60	TCG	10°	15°	4/9/100 + 2/9/110 + 2/14/110	LSB32006X	F03FS10101
	Utófor. elővágo	280	4,65	3,2	80	72	ATB	15°	15°	2/14/110	LI27M47VL3	F03FS08014
IMPACT 85 K	Fő-lap	350	4,4	3,2	80	72	TCG	15°	15°	4/9/100 + 2/9/110 + 2/14/110	LSB35005X	F03FS07635
	HW Elővágo	160	4,3-5,5	3,2	55	36	ATB	8°	15°	3/6/84 + 3/7/66	LI25M43LG3	F03FS02657
IMPACT 105 C/D, PLUS 105 C/D/P	Fő-lap	380	4,4	3,2	80	72	TCG	15°	15°	4/9/100 + 2/9/110 + 2/14/110	LSB38010X	F03FS07808
	HW Elővágo	160	4,3-5,5	3,2	55	36	ATB	8°	15°	3/6/84 + 3/7/66	LI25M43LG3	F03FS02657
IMPACT 90	Fő-lap	380	4,4	3,2	80	48	TCG	15°	15°	4/9/100 + 2/9/110 + 2/14/110	LSB38009X	F03FS09164
	HW Elővágo	160	4,3-5,5	3,2	55	36	ATB	8°	15°	3/6/84 + 3/7/66	LI25M43LG3	F03FS02657
	HW Elővágo	200	4,3-5,5	3,2	80	36	ATB	8°	15°	2/14/110	LI25M43PL3	F03FS02683
	Dia Elővágo	200	4,3-5,1	3,2	80	36	FLAT	6°	14°	2/14/110	DLI25M43PLH4	F03FS09627
	Dia Elővágo	200	4,3-5,1	3,2	80	36	FLAT	6°	14°	2/14/110	DLI25M43PLH6	F03FS09628
	Utófor. elővágo	300	4,7	3,2	80	72	ATB	15°	15°	2/14/110	LI27M DC3	F03FS02741
IMPACT 110	Fő-lap	400	4,4	3,2	80	72	TCG	15°	15°	4/9/100 + 2/9/110 + 2/14/110 + 2/14/125	LSB40012X	F03FS09173
	HW Elővágo	160	4,3-5,5	3,2	55	36	ATB	8°	15°	3/6/84 + 3/7/66	LI25M43LG3	F03FS02657
	HW Elővágo	200	4,3-5,5	3,2	80	36	ATB	8°	15°	2/14/110	LI25M43PL3	F03FS02683
	Dia Elővágo	200	4,3-5,1	3,2	80	36	FLAT	6°	14°	2/14/110	DLI25M43PLH4	F03FS09627
	Dia Elővágo	200	4,3-5,1	3,2	80	36	FLAT	6°	14°	2/14/110	DLI25M43PLH6	F03FS09628
	Utófor. elővágo	300	4,7	3,2	80	72	ATB	15°	15°	2/14/110	LI27M DC3	F03FS02741

Gép-típus	Lap-típus	D	B-B1	b	d	Z	Fog-típus	$\alpha$	$\beta$	ill. furatok	Freud kód	Cikksz.
		mm	mm	mm	mm							
<b>SCM-GABBIANI</b>												
<b>GALAXY 90</b>	Fő-lap	300	4,4	3	80	60	TCG	15°	15°	4/9/100 + 2/14/110	<b>LSB30004X</b>	F03FS09157
	Fő-lap	300	4,4	3	80	72	TCG	15°	15°	4/9/100 + 2/14/110	<b>LSB30008X</b>	F03FS07804
	HW Elővágo	200	4,3-5,5	3,2	80	36	ATB	8°	15°	2/14/110	<b>LI25M43PL3</b>	F03FS02683
	Dia Elővágo	200	4,3-5,1	3,2	80	36	FLAT	6°	14°	2/14/110	<b>DLI25M43PLH4</b>	F03FS09627
	Dia Elővágo	200	4,3-5,1	3,2	80	36	FLAT	6°	14°	2/14/110	<b>DLI25M43PLH6</b>	F03FS09628
	Utófor. elővágo	300	4,7	3,2	80	72	ATB	15°	15°	2/14/110	<b>LI27M DC3</b>	F03FS02741
<b>GALAXY 85</b>	Fő-lap	350	4,4	3,2	80	72	TCG	15°	15°	4/9/100 + 2/9/110 + 2/14/110	<b>LSB35005X</b>	F03FS07635
	HW Elővágo	200	4,3-5,5	3,2	80	36	ATB	8°	15°	2/14/110	<b>LI25M43PL3</b>	F03FS02683
	Dia Elővágo	200	4,3-5,1	3,2	80	36	FLAT	6°	14°	2/14/110	<b>DLI25M43PLH4</b>	F03FS09627
	Dia Elővágo	200	4,3-5,1	3,2	80	36	FLAT	6°	14°	2/14/110	<b>DLI25M43PLH6</b>	F03FS09628
<b>GALAXY 110, 110A</b>	Fő-lap	400	4,4	3,2	80	72	TCG	15°	15°	4/9/100 + 2/9/110 + 2/14/110 + 2/14/125	<b>LSB40012X</b>	F03FS09173
	HW Elővágo	200	4,3-5,5	3,2	80	36	ATB	8°	15°	2/14/110	<b>LI25M43PL3</b>	F03FS02683
	Dia Elővágo	200	4,3-5,1	3,2	80	36	FLAT	6°	14°	2/14/110	<b>DLI25M43PLH4</b>	F03FS09627
	Dia Elővágo	200	4,3-5,1	3,2	80	36	FLAT	6°	14°	2/14/110	<b>DLI25M43PLH6</b>	F03FS09628
<b>GALAXY 115</b>	Utófor. elővágo	300	4,7	3,2	80	72	ATB	15°	15°	2/14/110	<b>LI27M DC3</b>	F03FS02741
	Fő-lap	400	4,4	3,2	80	72	TCG	15°	15°	4/9/100 + 2/9/110 + 2/14/110 + 2/14/125	<b>LSB40012X</b>	F03FS09173
	HW Elővágo	200	4,3-5,5	3,2	80	36	ATB	8°	15°	2/14/110	<b>LI25M43PL3</b>	F03FS02683
	Dia Elővágo	200	4,3-5,1	3,2	80	36	FLAT	6°	14°	2/14/110	<b>DLI25M43PLH4</b>	F03FS09627
<b>GALAXY 130, 130A</b>	Dia Elővágo	200	4,3-5,1	3,2	80	36	FLAT	6°	14°	2/14/110	<b>DLI25M43PLH6</b>	F03FS09628
	Fő-lap	430	4,4	3,2	80	72	TCG	15°	15°	2/9/130 + 2/14/110 + 4/19/120	<b>LSB43009X</b>	F03FS07909
	HW Elővágo	200	4,3-5,5	3,2	80	36	ATB	8°	15°	2/14/110	<b>LI25M43PL3</b>	F03FS02683
	Dia Elővágo	200	4,3-5,1	3,2	80	36	FLAT	6°	14°	2/14/110	<b>DLI25M43PLH4</b>	F03FS09627
<b>GALAXY 145</b>	Dia Elővágo	200	4,3-5,1	3,2	80	36	FLAT	6°	14°	2/14/110	<b>DLI25M43PLH6</b>	F03FS09628
	Utófor. elővágo	300	4,7	3,2	80	72	ATB	15°	15°	2/14/110	<b>LI27M DC3</b>	F03FS02741
	Fő-lap	450	4,4	3,2	80	72	TCG	15°	15°	2/9/130 + 2/14/110 + 4/19/120	<b>LSB45009X</b>	F03FS07811
	HW Elővágo	200	4,3-5,5	3,2	80	36	ATB	8°	15°	2/14/110	<b>LI25M43PL3</b>	F03FS02683
<b>GALAXY 145</b>	Dia Elővágo	200	4,3-5,1	3,2	80	36	FLAT	6°	14°	2/14/110	<b>DLI25M43PLH4</b>	F03FS09627
	Dia Elővágo	200	4,3-5,1	3,2	80	36	FLAT	6°	14°	2/14/110	<b>DLI25M43PLH6</b>	F03FS09628











Gép-típus	Lap-típus	D	B-B1	b	d	Z	Fog-típus	α	β	ill. furatok	Freud kód	Cikksz.
		mm	mm	mm	mm							
GALAXY 140, ELITE	Fő-lap	450	4,4	3,2	80	72	TCG	15°	15°	2/9/130 + 2/14/110 + 4/19/120	LSB45009X	F03FS07811
	HW Elővágo	200	4,3-5,5	3,2	80	36	ATB	8°	15°	2/14/110	LI25M43PL3	F03FS02683
	Dia Elővágo	200	4,3-5,1	3,2	80	36	FLAT	6°	14°	2/14/110	DLI25M43PLH4	F03FS09627
	Dia Elővágo	200	4,3-5,1	3,2	80	36	FLAT	6°	14°	2/14/110	DLI25M43PLH6	F03FS09628
GALAXY3	Fő-lap	460	4,4	3,2	80	72	TCG	15°	15°	2/14/110 + 4/9/100	LSB46003X	F03FS09950
	HW Elővágo	200	4,3-5,5	3,2	80	36	ATB	8°	15°	2/14/110	LI25M43PL3	F03FS02683
	Dia Elővágo	200	4,3-5,1	3,2	80	36	FLAT	6°	14°	2/14/110	DLI25M43PLH4	F03FS09627
	Dia Elővágo	200	4,3-5,1	3,2	80	36	FLAT	6°	14°	2/14/110	DLI25M43PLH6	F03FS09628
<b>TÖRK MAKINE</b>												
MP70R	Fő-lap	320	4,4	3,2	75	72	TCG	15°	15°	3/7/100 + 3/13/95	LSB32002X	F03FS09162
	HW Elővágo	160	4,3-5,5	3,2	55	36	ATB	8°	15°	3/6/84 + 3/7/66	LI25M43LG3	F03FS02657
<b>TURANLAR</b>												
T-PE 433	Fő-lap	300	4,4	3	30	60	TCG	15°	15°	2/10/60	LSB30001X	F03FS07802
	Fő-lap	300	4,4	3	30	72	TCG	15°	15°	2/10/60	LSB30005X	F03FS07803
	HW Elővágo	150	4,3-5,6	3,2	30	36	ATB	8°	15°	-	LI25M43KC3	F03FS02649
T-PE 434 (2020. előtt)	Fő-lap	400	4,4	3,2	80	72	TCG	15°	15°	4/9/100 + 2/9/110 + 2/14/110 + 2/14/125	LSB40012X	F03FS07810
	HW Elővágo	200	4,3-5,5	3,2	65	36	ATB	8°	15°	2/9/100 + 2/9/110	LI25M43PI3	F03FS02681
T-PE 434	MFő-blap	430	4,4	3,2	80	72	TCG	15°	15°	2/9/130 + 2/14/110 + 4/19/120	LSB43009X	F03FS07909
	HW Elővágo	200	4,3-5,5	3,2	65	36	ATB	8°	15°	2/9/100 + 2/9/110	LI25M43PI3	F03FS02681
T-PE 435	MFő-blap	430	4,4	3,2	80	72	TCG	15°	15°	2/9/130 + 2/14/110 + 4/19/120	LSB43009X	F03FS07909
	HW Elővágo	200	4,3-5,5	3,2	65	36	ATB	8°	15°	2/9/100 + 2/9/110	LI25M43PI3	F03FS02681
T-PE 436 (2020. előtt)	MFő-blap	450	4,8	3,5	80	72	TCG	15°	15°	2/14/125 + 2/9/130 + 4/19/120	LSB45018X	F03FS07812
	HW Elővágo	200	4,7-5,9	3,5	65	36	ATB	8°	15°	2/9/100 + 2/9/110	LI25M47PI3	F03FS02720































# TALÁLJA MEG A TÖKÉLETES LAPSZABÁSZ FÜRÉSZLAPOT ÁTMÉRŐ SZERINT

































## LSB X teljes választék

































D	B	b	d	Z	$\alpha$	$\beta$	ill. furatok	G é p	Freud kód	Cikksz.
mm	mm	mm	mm							
250	4,2	3	30	60	15°	15°		SCM - Techmatic, Verry	 LSB25003X	F03FS10212
250	4,2	3	50	60	15°	15°		Usikraft	 LSB25005X	F03FS10214
250	4,2	3	55	60	15°	15°		Baldan, SCM - Techmatic	 LSB25002X	F03FS10211
250	4,4	3	30	80	15°	15°	2/9/46,4 + 2/10/60		 LSB25004X	F03FS10213
270	4,2	3	55	60	15°	15°		SCM - Techmatic	 LSB27001X	F03FS10215
280	4,4	3,2	55	60	15°	15°	2/10/70	Baldan	 LSB28001X	F03FS10216
290	4,2	3	55	60	15°	15°		SCM - Techmatic	 LSB29001X	F03FS10217
300	4,4	3	30	60	15°	15°	2/10/60	Panhans	 LSB30001X	F03FS07802
300	4,4	3	65	60	15°	15°	2/9/110	Selco	 LSB30002X	F03FS09159
300	4,4	3	75	60	15°	15°		Homag	 LSB30003X	F03FS10218
300	4,4	3	80	60	15°	15°	4/9/100 + 2/14/110	SCM	 LSB30004X	F03FS09157

D	B	b	d	Z	$\alpha$	$\beta$	ill. furatok	G é p	Freud kód	Cikksz.	
mm	mm	mm	mm								
300	4,4	3	30	72	15°	15°	2/10/60	Panhans, Verry		LSB30005X	F03FS07803
300	4,4	3,2	60	72	15°	15°	2/14/100	Holzma		LSB30012X	F03FS09207
300	4,4	3	65	72	15°	15°	2/9/95 + 2/9/110	Selco		LSB30006X	F03FS09158
300	4,4	3	75	72	15	15°		Holzma		LSB30007X	F03FS10219
300	4,4	3	80	72	15°	15°	4/9/100 + 2/14/110	SCM		LSB30008X	F03FS07804
300	4,4	3	75	96	15°	15°				LSB30010X	F03FS10220
305	4,4	3	30	60	15	15°	2/10/60	Mayer, Panhans, SCM		LSB30501X	F03FS10221
310	4,4	3,2	60	72	15°	15°	2/14/100	Holzma		LSB31001X	F03FS09949
320	4,4	3,2	30	60	15°	15°				LSB32005X	F03FS09160
320	4,4	3,2	50	60	15	15°	3/15/80 + 3/13/95	Giben		LSB32004X	F03FS10222
320	4,4	3,2	65	60	15°	15°	2/9/110	Selco		LSB32003X	F03FS09161
320	4,4	3,2	80	60	10°	15°	4/9/100 + 2/9/110 + 2/14/110			LSB32006X	F03FS10101
320	4,4	3,2	60	72	15	15	2/14/100			LSB32008X	F03FS10268
320	4,4	3,2	65	72	15°	15°	2/9/110	Selco		LSB32001X	F03FS07805
320	4,4	3,2	75	72	15°	15°	3/13/95 + 3/7/100	Giben		LSB32002X	F03FS09162
320	4,4	3,2	80	72	15°	15°	4/9/100 + 2/9/110 + 2/14/110			LSB32007X	F03FS10267
350	4,2	3,2	80	96	15°	15°				LSB35011X	F03FS10225
350	4,4	3,2	30	54	15°	15°	2/10/60	Panhans, Scheer		LSB35001X	F03FS10223
350	4,4	3,2	60	54	15°	15°	2/14/100	Holzma		LSB35002X	F03FS10224
350	4,4	3,2	30	72	15°	15°	2/10/60	Panhans, Scheer		LSB35003X	F03FS07630
350	4,4	3,2	50	72	15°	15°	4/13/80	Giben		LSB35006X	F03FS07709
350	4,4	3,2	60	72	15°	15°	2/14/100	Holzma		LSB35004X	F03FS07636
350	4,4	3,2	65	72	15°	15°	2/9/110	Selco		LSB35013X	F03FS09659
350	4,4	3,2	75	72	15°	15°		Giben, Hansol Machine		LSB35008X	F03FS07634
350	4,4	3,2	80	72	15°	15°	4/9/100 + 2/9/110 + 2/14/110	Gabbiani		LSB35005X	F03FS07635
355	4,4	3,2	75	54	15°	15°		Giben		LSB35502X	F03FS10226
355	4,4	3,2	80	54	15°	15°	4/9/100 + 2/9/110 + 2/14/110	Gabbiani		LSB35503X	F03FS09205
355	4,4	3,2	30	72	15°	15°	2/10/60	Panhans, SCM		LSB35504X	F03FS07674
355	4,4	3,2	65	72	15°	15°	2/9/95 + 2/9/110	Selco		LSB35508X	F03FS08740
355	4,4	3,2	75	72	15°	15°	4/15/105 + 2/7/110	Giben, KDT, Hold		LSB35505X	F03FS07633

<b>D</b>	<b>B</b>	<b>b</b>	<b>d</b>	<b>Z</b>	$\alpha$	$\beta$	<b>ill. furatok</b>	<b>G é p</b>	<b>Freud kód</b>	<b>Cikksz.</b>
<b>mm</b>	<b>mm</b>	<b>mm</b>	<b>mm</b>							
355	4,4	3,2	75	72	15°	15°	3/7/100	Gabbiani	 <b>LSB35507X</b>	F03FS07710
355	4,4	3,2	80	72	15°	15°	4/9/100 + 2/9/110 + 2/14/110	Gabbiani	 <b>LSB35506X</b>	F03FS09163
360	4,4	3	65	60	15°	15°	2/9/110	Selco	 <b>LSB36001X</b>	F03FS10227
360	4,4	3,2	30	72	15°	15°	2/13/94	Schelling	 <b>LSB36003X</b>	F03FS09341
360	4,4	3,2	65	72	15°	15°	2/9/110	Selco	 <b>LSB36002X</b>	F03FS07673
370	4,4	3,2	30	72	15°	15°	2/10/60	Schelling	 <b>LSB37001X</b>	F03FS10228
380	4,4	3,2	80	48	15°	15°	4/9/100 + 2/9/110 + 2/14/110	Gabbiani	 <b>LSB38009X</b>	F03FS09164
380	4,4	3,2	50	60	15°	15°	4/13/80	Giben	 <b>LSB38007X</b>	F03FS10230
380	4,4	3,2	60	60	15°	15°	2/14/100	Holzma	 <b>LSB38001X</b>	F03FS07806
380	4,4	3,2	30	72	15°	15°	2/08/83		 <b>LSB38011X</b>	F03FS10231
380	4,4	3,2	50	72	15°	15°	4/13/80	Giben	 <b>LSB38008X</b>	F03FS09165
380	4,4	3,2	60	72	15°	15°	2/14/100	Holzma	 <b>LSB38002X</b>	F03FS07631
380	4,4	3,2	65	72	15°	15°	2/9/110	Selco	 <b>LSB38014X</b>	F03FS09166
380	4,4	3,2	75	72	15°	15°	2/14/100	Holzma, Wonpoong	 <b>LSB38012X</b>	F03FS07672
380	4,4	3,2	80	72	15°	15°	4/9/100 + 2/9/110 + 2/14/110	Gabbiani	 <b>LSB38010X</b>	F03FS07808
380	4,4	3,2	60	84	15°	15°	2/14/100	Holzma	 <b>LSB38015X</b>	F03FS08989
380	4,4	3,2	80	96	15°	15°	4/9/100 + 2/9/110 + 2/14/110	Gabbiani	 <b>LSB38013X</b>	F03FS07809
380	4,8	3,5	60	60	15°	15°	2/14/100	Holzma	 <b>LSB38003X</b>	F03FS10229
380	4,8	3,5	60	72	15°	15°	2/14/100	Holzma	 <b>LSB38004X</b>	F03FS07632
380	4,8	3,5	60	84	15°	15°	2/14/100	Holzma	 <b>LSB38005X</b>	F03FS07807
390	4,4	3,2	80	72	15°	15°	2/14/110	Sigma	 <b>LSB39001X</b>	F03FS09167
400	4,4	3,2	30	48	15°	15°			 <b>LSB40001X</b>	F03FS09168
400	4,4	3,2	80	48	15°	15°	2/9/110 + 4/9/100 + 2/14/110	Gabbiani	 <b>LSB40010X</b>	F03FS10233
400	4,4	3,2	30	60	15°	15°	2/10/60		 <b>LSB40004X</b>	F03FS09169
400	4,4	3,2	75	60	15°	15°	4/15/105	Giben	 <b>LSB40005X</b>	F03FS09170
400	4,4	3,2	80	60	15°	15°	2/9/130 + 4/19/120	Selco	 <b>LSB40006X</b>	F03FS10232
400	4,4	3,2	80	60	15°	15°	4/9/100 + 2/9/110 + 2/14/110	Gabbiani	 <b>LSB40011X</b>	F03FS09171
400	4,4	3,2	30	72	15°	15°	2/10/60 + 2/13/94	Scheer	 <b>LSB40007X</b>	F03FS07725
400	4,4	3,2	50,8	72	15°	15°	2/16/127 + 4/13/80		 <b>LSB40018X</b>	F03FS08957
400	4,4	3,2	60	72	15°	15°	2/11/85 + 2/14/100	Antho	 <b>LSB40017X</b>	F03FS09272



D	B	b	d	Z	$\alpha$	$\beta$	ill. furatok	G é p	Freud kód	Cikksz.
mm	mm	mm	mm							
400	4,4	3,2	65	72	15°	15°	2/9/110	Selco	 <b>LSB40016X</b>	F03FS09172
400	4,4	3,2	75	72	15°	15°	4/15/105 + 2/7/110 + 2/14/100	Giben, Haisung Woodworking Machinery, Hansol Machine, HOMAG, Hyundai Sangi, KDT	 <b>LSB40008X</b>	F03FS07726
400	4,4	3,2	80	72	15°	15°	2/15/105 + 2/9/130 + 4/19/120	Selco, MAS	 <b>LSB40009X</b>	F03FS07810
400	4,4	3,2	80	72	15°	15°	4/9/100 + 2/9/110 + 2/14/110	Gabbiani	 <b>LSB40012X</b>	F03FS09173
400	4,4	3,2	60	84	15°	15°	2/14/100	Nanxing	 <b>LSB40021X</b>	F03FS09255
400	4,4	3,2	75	84	15°	15°	4/15/105 + 2/7/110	KDT	 <b>LSB40019X</b>	F03FS08990
400	4,8	3,5	60	72	15°	15°	2/14/125	Holzma	 <b>LSB40013X</b>	F03FS07711
420	4,4	3,2	80	60	15°	15°	4/9/100 + 2/9/110 + 2/14/110	Gabbiani	 <b>LSB42004X</b>	F03FS10235
420	4,4	3,2	50	72	15°	15°	2/9/130 + 4/19/120	Selco	 <b>LSB42006X</b>	F03FS09174
420	4,4	3,2	80	72	15°	15°	4/9/100 + 2/9/110 + 2/14/110	Gabbiani	 <b>LSB42005X</b>	F03FS09175
420	4,8	3,5	60	60	15°	15°	2/14/125	Holzma	 <b>LSB42001X</b>	F03FS10234
420	4,8	3,5	60	84	15°	15°	2/14/100 + 2/14/125	Holzma	 <b>LSB42002X</b>	F03FS09176
430	4,4	3,2	30	48	15°	15°			 <b>LSB43001X</b>	F03FS10236
430	4,4	3,2	75	48	15°	15°	4/15/105	Giben	 <b>LSB43002X</b>	F03FS10237
430	4,4	3,2	30	60	15°	15°	2/10/60		 <b>LSB43004X</b>	F03FS10238
430	4,4	3,2	75	60	15°	15°	4/15/105	Giben	 <b>LSB43005X</b>	F03FS10239
430	4,4	3,2	80	60	15°	15°	2/9/130 + 2/14/110 + 4/19/120	Selco - Gabbiani	 <b>LSB43006X</b>	F03FS10240
430	4,4	3,2	30	72	15°	15°			 <b>LSB43007X</b>	F03FS09177
430	4,4	3,2	65	72	15°	15°	2/9/110	Selco	 <b>LSB43012X</b>	F03FS09178
430	4,4	3,2	75	72	15°	15°	4/15/105 + 2/7/110	Giben	 <b>LSB43008X</b>	F03FS07908
430	4,4	3,2	80	72	15°	15°	2/9/130 + 2/14/110 + 4/19/120	Selco, Gabbiani	 <b>LSB43009X</b>	F03FS07909
430	4,4	3,2	75	96	15°	15°	4/15/105 + 2/7/110	Giben Prismatic	 <b>LSB43010X</b>	F03FS09179
430	4,8	3,5	70	72	15°	15°	4/11/130	Selco	 <b>LSB43013X</b>	F03FS09180
450	4,4	3,2	30	48	15°	15°	2/09/60	Mayer, Panhans, SCM	 <b>LSB45001X</b>	F03FS10241
450	4,4	3,2	60	48	15°	15°	2/14/125	Holzma	 <b>LSB45002X</b>	F03FS10242
450	4,4	3,2	30	60	15°	15°	2/10/60	Mayer, Panhans, SCM	 <b>LSB45004X</b>	F03FS10243
450	4,4	3,2	60	60	15°	15°	2/14/125	Holzma	 <b>LSB45005X</b>	F03FS10244
450	4,4	3,2	80	60	10°	15°	2/9/130 + 4/19/120 + 2/14/110	Selco - Gabbiani	 <b>LSB45006X</b>	F03FS10245
450	4,4	3,2	30	72	15°	15°	2/10/60 + 2/14/95	Mayer, Panhans, SCM	 <b>LSB45007X</b>	F03FS09181
450	4,4	3,2	60	72	15°	15°	2/14/125	Holzma	 <b>LSB45008X</b>	F03FS09182

D	B	b	d	Z	$\alpha$	$\beta$	ill. furatok	G é p	Freud kód	Cikksz.	
mm	mm	mm	mm								
450	4,4	3,2	80	72	15°	15°	2/9/130 + 2/14/110 + 4/19/120	Selco, Gabbiani		LSB45009X	F03FS07811
450	4,8	3,5	30	72	10°	15°	2/09/60	Scheer		LSB45016X	F03FS10246
450	4,8	3,5	60	72	15°	15°	2/14/125 + 2/17/100	Holzma, Nanxing		LSB45017X	F03FS07391
450	4,8	3,5	80	72	15°	15°	2/9/130 + 4/19/120	Selco		LSB45018X	F03FS07812
450	4,8	3,5	60	84	10°	15°	2/14/125	Holzma		LSB45019X	F03FS10247
460	4,4	3,2	30	72	15°	15°	2/13/94	Schelling		LSB46001X	F03FS08922
460	4,4	3,2	75	72	15°	15°	2/7/110	Giben		LSB46002X	F03FS07914
460	4,4	3,2	80	72	15°	15°	2/14/110 + 4/9/100	Gabbiani		LSB46003X	F03FS09950
470	4,4	3,2	75	48	15°	15°	4/15/105	Giben		LSB47001X	F03FS10248
470	4,4	3,2	75	60	15°	15°	4/15/105	Giben		LSB47002X	F03FS10249
470	4,4	3,2	75	72	15°	15°	4/15/105	Giben, Hyundai Sangi		LSB47003X	F03FS09183
470	4,4	3,2	75	96	15°	15°	4/15/105	Giben		LSB47004X	F03FS09184
470	4,8	3,5	70	72	15°	15°	4/11/130	Selco		LSB47005X	F03FS09185
480	4,4	3,2	30	72	15°	15°	2/10/60 + 2/13/94	Schelling		LSB48007X	F03FS09914
480	4,8	3,5	80	60	15°	15°	2/9/130 + 4/19/120	Selco		LSB48003X	F03FS09186
480	4,8	3,5	30	72	15°	15°	2/10/60 + 2/13/94	Schelling		LSB48004X	F03FS09187
480	4,8	3,5	60	72	15°	15°	2/19/120			LSB48006X	F03FS10269
480	4,8	3,5	80	72	15°	15°	2/9/130 + 4/19/120	Selco		LSB48001X	F03FS09188
500	4,4	3,2	30	60	15°	15°		Schelling		LSB50003X	F03FS10250
500	4,4	3,2	30	72	15°	15°		Schelling		LSB50005X	F03FS10251
500	4,8	3,5	60	60	15°	15°	2/11/115	Holzma		LSB50009X	F03FS09189
500	4,8	3,5	75	60	15°	15°	4/15/105	Giben		LSB50010X	F03FS09190
500	4,8	3,5	60	72	15°	15°	2/11/115	Holzma		LSB50011X	F03FS09191
510	4,8	3,5	80	72	15°	15°	2/9/130 + 4/19/120	Selco		LSB51001X	F03FS09984
520	4,4	3,2	30	54	15°	15°	2/13/94	Schelling		LSB52005X	F03FS10253
520	4,4	3,2	30	72	15°	15°	2/13/94	Schelling		LSB52008X	F03FS09602
520	4,8	3,5	60	60	15°	15°	2/11/115 + 2/19/120	Holzma		LSB52002X	F03FS10252
520	4,8	3,5	70	60	15°	15°	4/11/130			LSB52009X	F03FS09958
520	4,8	3,5	30	72	15°	15°	2/13/94	Schelling		LSB52007X	F03FS09319
520	4,8	3,5	60	72	15°	15°	2/11/115 + 2/19/120	Holzma		LSB52003X	F03FS09192

D	B	b	d	Z	$\alpha$	$\beta$	ill. furatok	G é p	Freud kód	Cikksz.
mm	mm	mm	mm							
520	4,8	3,5	70	72	15°	15°	4/11/130	Selco	 LSB52006X	F03FS09193
530	4,8	3,5	75	72	15°	15°	2/7/110	Giben	 LSB53004X	F03FS09651
530	5,2	3,5	30	60	15°	15°		Schelling	 LSB53001X	F03FS09194
530	5,2	3,5	100	60	15°	15°	2/7/140		 LSB53003X	F03FS09195
530	5,8	4	60	60	15°	15°	1/11/85	Anthon	 LSB53002X	F03FS10254
540	4,8	3,5	60	60	15°	15°	2/11/115 + 2/19/120	Holzma Typ 33	 LSB54002X	F03FS10255
540	4,8	3,5	60	72	15°	15°	2/11/115 + 2/19/120	Holzma Typ 33	 LSB54003X	F03FS10256
550	5	3,5	40	72	15°	15°	2/13/122	Schelling	 LSB55007X	F03FS09216
550	5,2	3,5	80	48	15°	15°	2/14/110	Gabbiani	 LSB55005X	F03FS10257
550	5,2	3,5	40	60	15°	15°	2/13/122		 LSB55009X	F03FS09915
550	5,2	3,5	60	60	15°	15°			 LSB55002X	F03FS09196
550	5,2	3,5	75	60	15°	15°	4/10,5/140		 LSB55010X	F03FS10030
550	5,2	3,5	80	60	15°	15°	2/14/110	Gabbiani	 LSB55006X	F03FS09197
550	5,2	3,5	90	60	15°	15°	4/10,5/140	Giben	 LSB55008X	F03FS09970
565	5	3,5	100	72	15°	15°		Giben	 LSB56504X	F03FS09215
565	5,2	3,5	100	60	15°	15°		Giben	 LSB56502X	F03FS09198
570	4,8	3,5	60	60	15°	15°	2/11/115 + 2/19/120	Holzma	 LSB57001X	F03FS09199
600	5,8	4	60	60	15°	15°	2/11/115 + 2/19/120	Holzma Typ 33	 LSB60001X	F03FS09200
600	5,8	4	70	60	15°	15°	4/11/130		 LSB60004X	F03FS10258
600	5,8	4	75	60	15°	15°	4/6,5/130 + 4/11/130	Selco	 LSB60006X	F03FS10259
600	5,8	4	60	72	15°	15°	2/11/115 + 2/19/120	Holzma Typ 33	 LSB60002X	F03FS09201
670	6,2	4,2	40	60	18°	13°	2/17/140 + 2/13/140	Schelling	 LSB67003X	F03FS09202
670	6,2	4,2	40	72	15°	15°	2/17/140 + 2/13/140	Schelling	 LSB67004X	F03FS10260
680	6,2	4,2	40	60	18°	13°	2/13/140 + 2/17/140 + 2/13/114	Schelling	 LSB68001X	F03FS09203
720	6,4	4,4	40	60	18°	13°	2/14/114 + 2/14/140	Schelling	 LSB72001X	F03FS09204

# Pontosan a legjobb

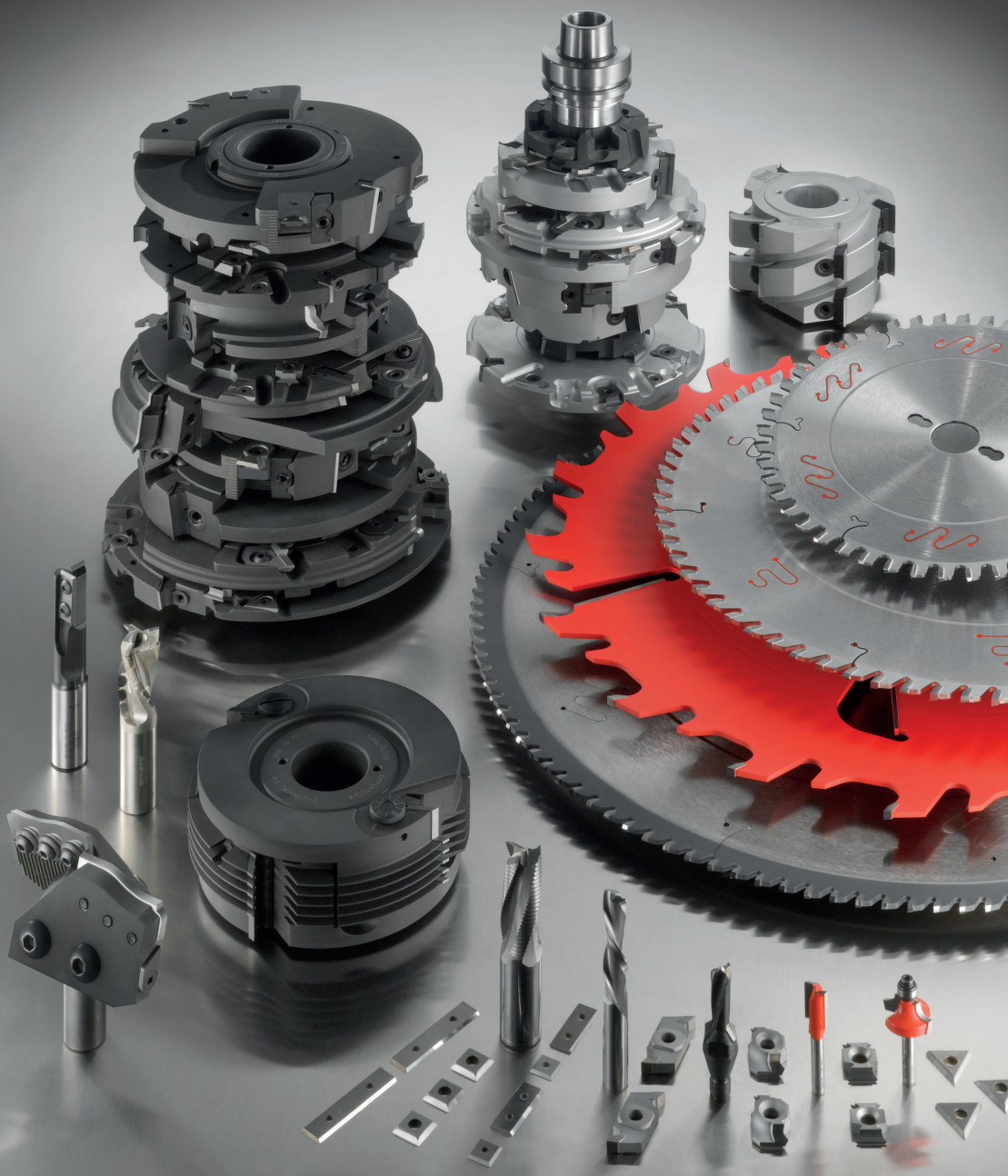



## Freud - iparági piacvezető 1962 óta

A Freud világméretű vezető szerepet tölt be a forgácsolószerszám iparban és a prémium körfűrészlapok legnagyobb gyártója. A Freud 1962. óta tervez és gyárt kiváló minőségű körfűrészlapokat, marófejeket és forrasztottlapkás marókat, fúrókat, felsőmarókat és CNC szerzőket, valamint késeket és tartozékokat.

## Freud technológiák és megoldások Tökéletesség az Ön igényeire.

A Freud prémium forgácsolószerszámokat egyedi és innovatív jellemzőkkel gyártják le. A vállalat birtokolja és ellenőrzi a teljes szerzőgyártási folyamatot olaszországi üzemében. A folyamatos befektetések a Kutatás és Fejlesztésbe kombinálva a Freud erős mérnöki kompetenciájával és a fejlett technológiákkal, innovatív tulajdonságokkal, rendkívüli pontossággal és hosszú élettartammal rendelkező termékeket eredményez. Mindig a megfelelő megoldás az Ön alkalmazási igényeinek megfelelően.

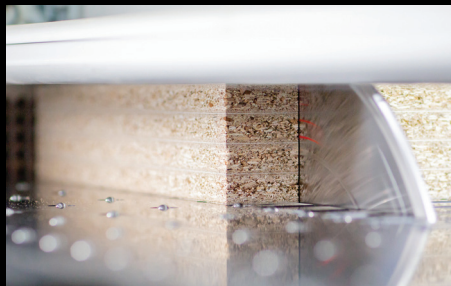

## Technológiai fölény Házon belüli vídiagyártás

Vezető a vídiagyártásban 1980 óta: a Freud büszke arra, hogy a világon egyedülálló a vídi komponensek házon belüli gyártása és szinterézése a kiváló minőségű vágószerszámokhoz. A Freud TiCo, a titán- és a kobaltkarbid speciálisan kimunkált, rendkívül kompakt kombinációja maximális pontosságot és hosszantartó élességet biztosít a forgácsolóél számára. A standard és a testreszabott alkalmazásokhoz dedikált receptúrák megformulálásának képessége a legmagasabb szerzőámteljesítményt nyújtja.

## Világméretű értékesítés Globális szerviz akárhol is van Ön

A Freud "globális gondolkodás és helyi cselekvés" hitvallása arra készítette a vállalatot, hogy kiválasztott partnerek és leányvállalatok kiterjedt hálózatát fejlessze ki a világ 90 országában. Mindezt az ügyfelek jobb támogatásáért bárhol is legyenek.

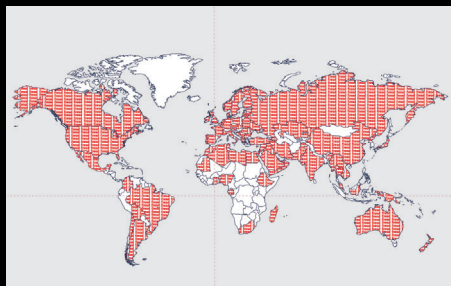

# freud

---

**freud S.p.A.**  
**Società Unipersonale**  
Via Remigio Solari, 7  
33050 Pavia di Udine (UD) IT

[www.freudtools.com](http://www.freudtools.com)



**Magyarországon forgalmazza:**  
**SZERKER 2006 Kft.**  
2163 Vácrátót, Kinizsi u. 6.  
Tel: 06-20-521 5345 e-mail: szerker@szerker.hu

[www.szerker.hu](http://www.szerker.hu)



MKFRM 219 - F03FA23637 - Printed in Italy - September 2022 - Rev. 0